

CONTRACT C19123

**CERONE DIVISION  
BOILER & PROPANE TANK  
REPLACEMENT**

Invitation for Bid  
November 9, 2020



*Solutions that move you*



## TABLE OF CONTENTS

<b>SECTION 1 INVITATION FOR BID .....</b>	<b>1-1</b>
1.1. Introduction.....	1-1
1.2. Obtaining the Contract Documents.....	1-1
1.3. Description of Work.....	1-1
1.4. Submittal Location and Deadline.....	1-2
1.5. Licenses.....	1-2
1.6. Bidding and Contract Information.....	1-2
1.7. Business Diversity Program .....	1-3
1.8. Reserved.....	1-3
1.9. Pre-Qualification Requirements .....	1-3
1.10. Pre-Bid Meeting and Project Site Tour .....	1-3
1.11. Communication Protocol.....	1-4
1.12. Confidentiality .....	1-4
1.13. Reservations of Rights of VTA.....	1-5
<b>SECTION 2 FOREWORD.....</b>	<b>2-1</b>
2.1. Overview of Santa Clara Valley Transportation Authority.....	2-1
2.2. Equal Opportunity Employer .....	2-1
2.3. Description of the Contracting Process .....	2-1
2.3.1. General Process .....	2-1
2.3.2. Notice of Award .....	2-2
2.3.3. Bid Security.....	2-2
2.3.4. Executed Contract and Notice to Proceed .....	2-3
2.4. State and Federal Tax Forms .....	2-4
2.5. Definitions.....	2-4
<b>SECTION 3 INSTRUCTIONS TO BIDDERS .....</b>	<b>3-1</b>
3.1. Pre-Bid Meeting.....	3-1
3.2. Examination of the Contract Documents .....	3-1
3.3. Examination of Site and Existing Conditions .....	3-1
3.4. Addenda to Contract Documents .....	3-1
3.5. Prevailing Wage Requirements .....	3-2
3.6. Workers Compensation .....	3-2
3.7. Reserved.....	3-3
3.8. Business Diversity.....	3-3
3.8.1. Goal.....	3-3
3.8.2. Business Diversity Policy and Requirements .....	3-3
3.9. Preparation of Bid.....	3-3
3.9.1. Submit Bid on Form Provided .....	3-3
3.9.2. Prices, Taxes and Applicable Fees in the Bid .....	3-4
3.9.3. Sealed Envelope.....	3-4
3.10. Bid Forms.....	3-4
3.10.1. Bid Form 1: Schedule of Quantities and Prices.....	3-4

Cerone Division Boiler & Propane Tank Replacement  
Contract C19123

---

3.10.2.	Bid Form 2: Bid Security Form/ Bidder’s Bond .....	3-4
3.10.3.	Bid Form 3: Designation of Subcontractors .....	3-4
3.10.4.	Bid Form 4: Listing of SBE Contractor or Subcontractors .....	3-5
3.10.5.	Bid Form 5: Supplemental Contractor and Subcontractor Information .....	3-5
3.10.6.	Bid Forms 6 to 7 and 10.....	3-5
3.10.7.	Bid Forms 8 to 9.....	3-5
3.11.	Bids and Bid Opening.....	3-5
3.11.1.	Late Bids .....	3-5
3.11.2.	Withdrawal of Bid .....	3-5
3.11.3.	Conditional Bids.....	3-5
3.11.4.	Bidders Interested in More than One Bid.....	3-5
3.11.5.	Single Bid Response .....	3-6
3.12.	Award or Rejection of Bids .....	3-6
3.12.1.	Award Process .....	3-6
3.13.	Basis of Award .....	3-6
3.14.	Responsibility Hearing.....	3-6
3.15.	Bidder Review and Protest Procedures .....	3-7
3.15.1.	General Information .....	3-7
3.15.2.	Pre-Bid Opening Protests .....	3-7
3.15.3.	Post Bid Opening Protests .....	3-7
<b>SECTION 4</b>	<b>BID FORMS.....</b>	<b>4-1</b>
BID FORM 1.....		1
BID FORM 2.....		1
BID FORM 3.....		1
BID FORM 4.....		1
BID FORM 5.....		1
BID FORM 6.....		1
BID FORM 7.....		1
BID FORM 8.....		1
BID FORM 9.....		1
BID FORM 10.....		1
<b>SECTION 5</b>	<b>CONTRACT FORMS .....</b>	<b>5-1</b>
CONTRACT FORM 1.....		1
CONTRACT FORM 2.....		1
CONTRACT FORM 3.....		1
CONTRACT FORM 4.....		1
CONTRACT FORM 5.....		1
<b>SECTION 6</b>	<b>SPECIAL CONDITIONS .....</b>	<b>6-1</b>
6.1.	Indemnity and Defense of Claims .....	6-1
6.1.1.	Indemnify and Hold Harmless .....	6-1
6.1.2.	Limitation on Indemnity .....	6-1
6.1.3.	Duty to Defend .....	6-1
6.1.4.	Survive Expiration or Termination .....	6-1
6.2.	Insurance.....	6-2
6.3.	Contract Bonds and Surety Requirements .....	6-2
6.3.1.	Payment Bond .....	6-2
6.3.2.	Performance Bond.....	6-2

Cerone Division Boiler & Propane Tank Replacement  
Contract C19123

---

6.3.3. Surety Requirements .....	6-2
6.4. Time for Performance .....	6-3
6.5. Liquidated Damages .....	6-3
6.6. Contract Data Requirements .....	6-3
6.6.1. Contract Data Requirements .....	6-3
6.6.2. Submittal .....	6-3
6.7. Permits, Fees and Inspections .....	6-6
6.8. Payment of Fines and Fees .....	6-6
6.9. VTA Furnished Materials .....	6-7
6.10. Delivery, Unloading and Storage .....	6-7
6.11. Work Sequence and Constraints .....	6-7
6.11.1. Construction Hours.....	6-7
6.11.2. Building Access .....	6-7
6.11.3. Preservation of Services .....	6-8
6.11.4. Preservation of Diesel & LPG Refueling Access .....	6-9
6.11.5. Utility Trenching Requirements.....	6-9
6.11.6. Coordination with VTA Contract C19010.....	6-9
6.11.7. Preservation of Service to Existing Equipment .....	6-10
6.11.8. Utility Shutdowns, Interruptions, and Cut-overs.....	6-10
6.12. Reserved.....	6-10
6.13. Sound Control Requirements .....	6-10
6.14. Safety Precautions, Programs and First Aid Requirements .....	6-11
6.14.1. Safety Supervision .....	6-11
6.14.2. Hazardous Substances .....	6-12
6.14.3. Safety Data Sheets and Hazardous Substances .....	6-12
6.14.4. Hazardous Substances Controls and Storage .....	6-12
6.14.5. Written Safety Precautions.....	6-13
6.14.6. Protection of Work and Property; Responsibility for Loss.....	6-14
6.14.7. VTA Patrols .....	6-14
6.14.8. Notice in Writing Before Breaking Ground.....	6-14
6.14.9. Safeguards for Safety and Protection .....	6-14
6.14.10. Job Safety Compliance .....	6-14
6.14.11. Damage to the Work .....	6-15
6.14.12. Dangerous Conditions .....	6-15
6.14.13. Emergencies .....	6-15
6.15. Reserved.....	6-16
6.16. Access and Working Hours .....	6-16
6.17. Contractor Cooperation and Coordination.....	6-16
6.18. Substantial Completion and Acceptance.....	6-16
6.18.1. Substantial Completion .....	6-16
6.18.2. Punch List Items.....	6-16
6.18.3. Final Acceptance.....	6-17
6.19. Final Pay Quantities .....	6-17
6.20. Project Close-Out Requirements – Record Drawings .....	6-18
6.21. Progress Schedule .....	6-18
6.21.1. General Requirements.....	6-18
6.21.2. Reserved .....	6-19
6.21.3. Schedule Float .....	6-19
6.21.4. Reserved .....	6-19
6.21.5. Baseline CPM Schedule.....	6-19

Cerone Division Boiler & Propane Tank Replacement  
Contract C19123

---

6.21.6. Schedule Update.....	6-21
6.21.7. Three-Week Look-Ahead Schedule .....	6-22
6.21.8. Schedule Revisions .....	6-22
6.21.9. Recovery Schedule.....	6-22
6.21.10. Time Impact Evaluation for Change Orders and Delays .....	6-23
6.21.11. Time Extensions.....	6-23
6.21.12. Adverse Weather Delays .....	6-24
6.21.13. Payment Provisions .....	6-24
6.22. References to Days .....	6-25
6.23. Reserved.....	6-26
6.24. Reserved.....	6-26
6.25. Reserved.....	6-26
6.26. Quality Assurance and Quality Control Requirements .....	6-26
6.27. Environmental Coordination and Cooperation .....	6-26
6.28. Reserved.....	6-26
6.29. Reserved.....	6-26
6.30. Compliance and Testing for Highway and Transit Pavement .....	6-26
<b>SECTION 7 GENERAL CONDITIONS .....</b>	<b>7-1</b>
7.1. Applicable Law and Jurisdiction.....	7-1
7.2. Compliance with Laws and Regulations .....	7-1
7.3. Contractor Licensing Requirements .....	7-1
7.4. Independent Contractor .....	7-1
7.5. Permits, Licenses, Fees and Notices .....	7-2
7.6. Nondiscrimination .....	7-2
7.7. Prohibited Interests.....	7-2
7.7.1. Solicitation .....	7-2
7.7.2. Interest of Public Officials.....	7-3
7.7.3. Interests of Contractor .....	7-3
7.8. Labor Provisions .....	7-3
7.8.1. Register with DIR .....	7-3
7.8.2. Safety .....	7-3
7.8.3. Overtime Requirements .....	7-3
7.8.4. Prevailing Wage Rates .....	7-3
7.8.5. Liability for Unpaid Wages.....	7-4
7.8.6. Withholding for Unpaid Wages and Liquidated Damages.....	7-4
7.8.7. Travel and Subsistence Payments .....	7-4
7.8.8. Retention of Labor Records .....	7-4
7.8.9. Employment of Apprentices .....	7-5
7.8.10. Subcontracts .....	7-5
7.9. Hazardous Materials or Unusual Conditions .....	7-5
7.10. Reserved.....	7-6
7.11. Reserved.....	7-6
7.12. Patent Rights .....	7-6
7.13. Intellectual Property, Copyright and Patent Infringement.....	7-6
7.14. Rights in Technical Data.....	7-6
7.15. Ownership of Work and Material .....	7-7
7.16. Title and Risk of Loss.....	7-7
7.17. Assignment and Delegation .....	7-7
7.18. Subcontracts.....	7-7

Cerone Division Boiler & Propane Tank Replacement  
Contract C19123

---

7.19. Waiver and Non-waiver.....	7-7
7.20. Antitrust Claims .....	7-8
7.21. Stop Notices.....	7-8
7.22. Reserved.....	7-8
7.23. Reserved.....	7-8
7.24. Authorized Representatives .....	7-8
7.25. Notices and Communications.....	7-9
7.25.1. Notices.....	7-9
7.25.2. Drawing/Plan Clarification.....	7-9
7.25.3. Requests for Information (RFIs).....	7-9
7.26. Pre-Construction Meeting.....	7-10
7.27. Project Meetings .....	7-11
7.28. Publicity Releases .....	7-11
7.29. Notice to Proceed.....	7-11
7.30. Time of Completion .....	7-11
7.31. Progress Schedule .....	7-12
7.32. Excusable Delays and Extensions of Time .....	7-12
7.33. Failure to Complete the Work on Time .....	7-12
7.34. Contractor’s Work Area.....	7-12
7.35. Temporary Construction Facilities and Utilities .....	7-13
7.36. Character of Workers .....	7-13
7.37. Working Environment .....	7-13
7.38. Public Convenience and Safety.....	7-13
7.39. Cooperation/Coordination and Work by Others.....	7-13
7.40. Security.....	7-14
7.41. Product Options, Supplier Approval and Substitutions.....	7-14
7.42. Source of Materials .....	7-14
7.43. Submittal of Shop Drawings, Product Data and Samples .....	7-14
7.44. Survey Requirements .....	7-15
7.44.1. Lines and Grades.....	7-15
7.44.2. Monument Preservation .....	7-16
7.45. Protection and Restoration of Property .....	7-17
7.46. Utility Paint Markings .....	7-18
7.47. Reserved.....	7-18
7.48. Inspection.....	7-18
7.49. Certificates of Compliance and Testing .....	7-18
7.49.1. Certificates of Compliance.....	7-18
7.49.2. Testing .....	7-19
7.49.3. Furnish without Charge .....	7-19
7.50. Removal of Rejected or Unauthorized Work.....	7-19
7.51. Disposal of Materials .....	7-19
7.52. Protection of Completed Portions of Work.....	7-19
7.53. Clean-up.....	7-20
7.54. Redlined Construction Drawings .....	7-20
7.55. Final Inspection and Acceptance of All or a Portion of the Work.....	7-20
7.55.1. Final Inspection and Acceptance of all the Work .....	7-20
7.55.2. Final Inspection and Acceptance of a Portion of the Work .....	7-21
7.56. Compensation .....	7-21
7.57. Increased or Decreased Quantities and Quantity Variation.....	7-22
7.58. Certified Payrolls .....	7-23

Cerone Division Boiler & Propane Tank Replacement  
Contract C19123

---

7.58.1. Submit Certified Copies .....	7-23
7.58.2. Form of Certified Copies .....	7-23
7.59. Progress Payment .....	7-24
7.59.1. Schedule of Values .....	7-24
7.59.2. Progress Payment Processing .....	7-24
7.59.3. Full Compensation .....	7-25
7.59.4. Materials on Hand .....	7-25
7.59.5. Retention .....	7-25
7.59.6. Special Withholding .....	7-26
7.59.7. Substitution of Securities .....	7-26
7.60. Force Account Payment .....	7-30
7.60.1. Work Performed by Contractor .....	7-30
7.60.2. Labor .....	7-30
7.60.3. Materials .....	7-31
7.60.4. Equipment Rental .....	7-31
7.60.5. Equipment at the Worksite .....	7-32
7.60.6. Equipment Not at the Worksite .....	7-32
7.60.7. Work Performed by Special Forces or Other Special Services .....	7-34
7.60.8. Owner-Operated Equipment .....	7-34
7.61. Prompt Payment .....	7-35
7.61.1. Prompt Payment to Contractor .....	7-35
7.61.2. Payment to Subcontractors .....	7-35
7.62. Final Payment .....	7-35
7.63. Project Records .....	7-36
7.64. Reserved .....	7-36
7.65. Change Requests and Change Notices .....	7-36
7.65.1. Change Request .....	7-36
7.65.2. Change Notices .....	7-37
7.66. Change Order .....	7-38
7.67. Differing Site Conditions .....	7-38
7.67.1. Soil Boring or Other Data .....	7-38
7.67.2. Notice of Differing Conditions .....	7-38
7.68. Claims and Claim Resolution .....	7-38
7.68.1. Claim Defined .....	7-38
7.68.2. Claim Requirements .....	7-39
7.68.3. Claim Review .....	7-40
7.68.4. Payment of Undisputed Portion .....	7-40
7.68.5. Meet and Confer .....	7-40
7.68.6. Inaction Deemed Rejection .....	7-41
7.68.7. Subcontractor Claims .....	7-41
7.68.8. Waivers of Rights under Public Contract Code Section 9204 .....	7-41
7.68.9. Procedures for Civil Actions .....	7-41
7.69. Suspension of Work .....	7-42
7.70. Termination for Convenience or in the Public Interest .....	7-43
7.71. Termination for Default .....	7-43
7.71.1. Events or Conditions .....	7-43
7.71.2. Notice and Procedures .....	7-45
7.72. Contractor's Duties Upon Termination .....	7-46
7.73. Warranty .....	7-46
7.74. Warranty Work .....	7-46

Cerone Division Boiler & Propane Tank Replacement  
Contract C19123

---

7.75. Warranty on Repaired or Replaced Parts ..... 7-47  
7.76. Systematic Failures ..... 7-47

**SECTION 8 TECHNICAL SPECIFICATIONS .....8-1**

**SECTION 9 CONTRACT DRAWINGS / PLANS .....9-1**

**APPENDICES .....1**

Appendix A Insurance Requirements .....1  
Appendix B Contract Data Requirements .....1  
Appendix C Business Diversity Policy and Requirements.....1  
Appendix D Reserved .....1  
Appendix E Reserved .....1  
Appendix F Reserved .....1  
Appendix G Environmental Coordination and Cooperation .....1  
Appendix H Reserved .....1  
Appendix I Prequalification Requirements .....1  
Appendix J Reserved .....1  
Appendix K Reserved .....1  
Appendix L Reserved .....1  
Appendix M Quality Assurance and Quality Control Requirements .....1  
Appendix N Regulatory Permit Applications .....1  
Appendix O Hazardous Material Survey Report .....1  
Appendix P VTA Contract C19010 Reference Drawings.....1  
Appendix Q Guidelines for Preparation of IIPP & SSSP.....1  
Appendix R Existing Utility Information .....1  
Appendix S Procedure on Reflective Safety Vests .....1  
Appendix T Bldg G HHW & Propane Reference Drawing.....1

*[This Page Intentionally Left Blank]*



## SECTION 1 INVITATION FOR BID

### 1.1. Introduction

The Santa Clara Valley Transportation Authority (“VTA”) is requesting sealed written bids (“Bids”; “Bid”) from responsive and responsible qualified firms (“Bidders”) for the project titled below (“Project”):

**Cerone Division Boiler & Propane Tank Replacement  
Contract C19123**

### 1.2. Obtaining the Contract Documents

Contract documents (herein referred to as “Contract Documents”) specifying the requirements of the work to be performed (“Work”), the terms of the contract (“Contract”) between VTA and the successful Bidder, and the details of the bidding procedure can be found at VTA’s website <https://www.vta.org/solicitations>. Click on the name of the solicitation that you are interested in.

To download documents for a solicitation, click "**Register or Log In to Download**" if you are not already logged in, and once you are registered and logged in, click "**Become a Plan Holder**" in order to download the documents. There is no charge for downloading these documents.

Register as a vendor and sign up for notifications for your North American Industry Classification System (“NAICS”) business codes at <https://www.vta.org/user/register?type=vendor>. By registering as a VTA vendor, Bidder will automatically receive notifications by email of upcoming VTA bidding opportunities.

**It is highly recommended that prospective Bidders acquire the Contract Documents directly from VTA’s website in order to bid on this project and be assured that their Bids include all addenda. Bids that do not acknowledge receipt of addenda may be considered nonresponsive.**

### 1.3. Description of Work

For purposes of this Contract, the Work consists of furnishing all labor, materials, tools, equipment, services, supervision, and incidentals necessary to replace the propane gas storage and distribution system, and to modify the existing Heating Hot Water (HHW) boiler system at VTA’s Cerone Division bus operations and maintenance facility located at 3990 Zanker Rd., San Jose.

Contractor will install a new propane storage and distribution system consisting of a 30,000-gallon Liquefied Petroleum Gas (LPG) storage tank, fill station, LPG vaporizers, all associated above and below ground piping, valves, safety equipment, connection to existing propane pipe networks, and testing and commissioning of the propane storage and delivery system. The Work includes related controls and monitoring systems, constructing concrete support structures, and all related civil, electrical, and plumbing work. Upon commissioning of the new propane systems, Contractor will decommission, demolish, and dispose of the existing propane storage tank and system, including related fill port, piping and vaporizers.

Contractor will modify the existing HHW boiler system, including constructing a new water treatment system for the existing centralized boiler plant in Building F. Contractor will also modify and replace HHW distribution piping from Building F to the adjacent buildings served, and restore the HHW system to proper operation. Contractor will also remove unused remnants of an older decommissioned boiler system from Building F.

The Engineer's Estimate for this Work ranges from **\$1,000,000 to \$1,800,000**. Refer to **Section 6.4 Time for Performance** for the time limit to complete all Work.

#### **1.4. Submittal Location and Deadline**

Bids must be submitted on ("Bid Opening") or before:

**December 16, 2020 at 2:00 PM**

Bids received after the date and time stated above will be rejected as nonresponsive. It is highly recommended that Bids be hand-delivered.

All Bids must be enclosed in a sealed envelope bearing the Contract number, the title of the Project, the date and hour of the opening, and the name of the Bidder.

Bids will be received, publicly opened and read aloud at the location set forth below:

**Santa Clara Valley Transportation Authority  
Procurement, Contracts and Materials Management  
Attention: Kiet Vu  
3331 North First Street, Building A  
San José, California 95134**

**Important note:** Only one representative from each contractor is allowed to attend the Bid Opening. Masks or face coverings and social distancing of six feet or more will be required. Additional requirements imposed by the Health Officer of the County of Santa Clara at the time of the meeting may apply.

#### **1.5. Licenses**

The Bidder to whom the Contract will be awarded ("Contractor") must, at the time of Bid submittal, possess current licenses in the following classifications issued by the California Department of Consumer Affairs, Contractors State License Board:

**License:** Class A (General Engineering) or Class B (General Building)

Contractor and subcontractors of all tiers must be properly licensed to perform the Work they undertake. Contractor and all subcontractors must also have current registration on file with the Department of Industrial Relations (DIR), pursuant to Section 172.5 of the California Labor Code, at the time of Bid opening.

Regardless of whether a subcontractor must be identified at the time of Bid, each subcontractor must also be properly licensed to perform its scope of work.

#### **1.6. Bidding and Contract Information**

Detailed instructions for the submittal of Bids are provided in **Section 3 Instructions to Bidders** and **Section 4 Bid Forms** of these Contract Documents. Items to especially note are listed in the table below:

Bid Forms to Submit	Refer to <b>Section 4 Bid Forms</b> for a list of required forms and certifications to submit at time of bid opening.
---------------------	---

Bid Security	Each Bid must be accompanied by a certified check, a cashier's check or a bidder's bond in the sum of not less than 5% of the Total Bid Price. Refer to <b>Section 3.10.2 Bid Security Form/ Bidder's Bond</b> .
Prevailing Wages	This project is a "public work" as defined in Sections 1720 through 1720.6 of the California Labor Code. This Contract is subject to the prevailing wages as described in <b>Section 3.5 Prevailing Wage Requirements</b> .
Department of Industrial Relations Registration	<b>Contractor and all subcontractors used for the Contract must be registered, pursuant to Section 1725.5 of the California Labor Code, at the time of Bid Opening.</b> This project is subject to compliance monitoring and enforcement by the Department of Industrial Relations ("DIR"). Refer to <b>Section 3.5 Prevailing Wage Requirements</b> .
Pre-Qualification	Pre-Qualification is required as defined in <b>Section 1.9 Pre-Qualification Requirements</b> .
Contract Forms to Submit	Refer to <b>Section 5 Contract Forms</b> for a list of required forms and certifications to submit at time of award. These forms are for reference only and are not to be submitted with the Bid Forms.
Additional Information	This project is locally funded.

### **1.7. Business Diversity Program**

A 2.46% participation goal for Small Business Enterprise ("SBE") has been established for this Contract. Refer to **Section 3.8 Business Diversity** and **Appendix C Business Diversity Policy and Requirements** for additional information.

### **1.8. Reserved**

### **1.9. Pre-Qualification Requirements**

This Contract requires Pre-Qualification of all prospective Bidders. The Pre-Qualification application is contained in **Appendix I Pre-Qualification Requirements**.

Prospective Bidders that are not pre-qualified may qualify during the solicitation period, up to two days before Bid Opening. Prospective Bidders not currently pre-qualified, and intending to be pre-qualified, must request Pre-Qualification sufficiently in advance of the Bid Opening so as to ensure there will be no need to extend the solicitation period or delay the award.

### **1.10. Pre-Bid Meeting and Project Site Tour**

A Pre-Bid Meeting will be held at the following location and time:

Santa Clara Valley Transportation Authority  
Procurement, Contracts and Materials Management  
**3331 North First Street, Building A**  
San José, California 95134

on

**November 19, 2020 , at 2:00 PM**

A site tour will be held promptly following the pre-Bid meeting at:

VTA Cerone Division  
**3990 Zanker Road**  
**San Jose, California 95134**

*Check-in with the guard will be required. Details to be provided at the Pre-Bid Meeting.*

**Important note:** Only one representative from each contractor is allowed to attend the Pre-Bid meeting. Masks or face coverings and social distancing of six feet or more will be required for both the Pre-Bid meeting and the Site Tour. Additional requirements imposed by the Health Officer of the County of Santa Clara at the time of the meeting may apply.

### **1.11. Communication Protocol**

Please direct inquiries concerning the Contract Documents, bidding procedure and legal requirements to the designated Contract Administrator for this project:

Contract Administrator: Kiet Vu  
Email: Kiet.Vu@vta.org

The deadline for submitting inquiries will be 10 AM, five (5) working days before Bid Opening date.

Bidders may not communicate with VTA Directors, Officers, staff or consultants. All requests for clarification, objections to or questions about the structure, content or distribution of this Invitation for Bids ("IFB"), or other inquiries during the procurement process must be submitted via email to the Contract Administrator. Communicating with any VTA representative(s) about this IFB other than as specifically permitted herein is grounds for disqualification.

Questions and/or objections must be as specific as possible and must identify the name of the project and the IFB section number and title at issue. Any party submitting a question or objection must be as specific as possible in their description.

Bidders shall only rely on information contained in this IFB, and any subsequent written supplement issued by the VTA through VTA's bid process. Bidders shall not rely on any other written or oral statements of the VTA or its officers, directors, employees, or agents regarding the Work, including statements made during site tours or otherwise.

### **1.12. Confidentiality**

All information submitted to VTA under this IFB process becomes the exclusive property of VTA but, if not otherwise a public record under the California Public Records Act (California Government Code Section 6250 et seq.), shall not be open to public inspection. VTA has a substantial interest in not disclosing submissions during the evaluation process. For this reason, VTA will not disclose any part of the Bids before issuance of the Notice of Recommended Award, after which time all submissions will be subject to public disclosure to the extent such information constitutes a public record under the California Public Records Act.

**1.13. Reservations of Rights of VTA**

VTA reserves, holds and may exercise, at its sole discretion, the following rights and conditions with regard to this IFB, and by responding to this IFB, Bidders acknowledge and consent to the following rights and conditions:

- VTA reserves the right to issue addenda to amend this IFB or any related forms or document, or any reference information provided to Bidders.
  - VTA reserves the right to respond to inquiries after the deadline for submitting inquiries.
  - VTA reserves the right to cancel the procurement, to reject any and all Bids, or to negotiate separately in any manner necessary to serve the best interests of VTA, in accordance with applicable law.
  - VTA reserves the right to waive any informality or immaterial irregularity in any Bid and/or accept or reject any items of a Bid
  - This IFB does not obligate VTA to procure or to contract for any services.
  - VTA reserves the right to change or alter the schedule for any events associated with this IFB upon notice to all potential Bidders.
  - VTA reserves the right to eliminate any Bidder who submits incomplete or inadequate responses or is not responsive to the requirements of this IFB.
  - VTA reserves the right to interview any or all Bidder references and to clarify the information provided pursuant to this IFB.
- 

**By order of the Santa Clara Valley Transportation Authority, State of California.**

**Approved for posting:**



\_\_\_\_\_  
Daren Gee, P.E.

\_\_\_\_\_  
11/05/2020

Date

Construction Contracts Administration Manager  
VTA Procurement, Contracts and Materials Management

*[This Page Intentionally Left Blank]*

## SECTION 2 FOREWORD

### 2.1. Overview of Santa Clara Valley Transportation Authority

Santa Clara County is comprised of 15 cities and has a total population of 1.6 million people. The Santa Clara Valley Transportation Authority provides transit services in this area, including approximately 326 square miles in the urbanized portion of Santa Clara County. VTA currently operates 75 bus routes and the Guadalupe, Tasman, Vasona and Capitol Corridor light rail transit (LRT) lines. It also funds inter-regional commuter rail and express bus service, paratransit services, and light rail shuttle bus services to enhance the core transit system.

Working under a 17-member Board of Directors, VTA has a \$420 million annual budget and its currently approved capital program is approximately \$2.3 billion. It owns a fleet of 495 buses and 99 rail cars as well as 4 historic trolleys. VTA employs approximately 2,100 people.

VTA offers 42.2 miles of light rail extending from the Silicon Valley industrial and residential areas of Milpitas, Mountain View, Sunnyvale and Santa Clara to residential areas in South and East San José. The Light Rail System has 61 stations and multi-modal connections with CalTrain at the Mountain View and Tamien Station. This light rail system is one of the longest to be built in the U.S. in 50 years.

### 2.2. Equal Opportunity Employer

VTA is an Equal Opportunity employer. Contractors must comply with the Equal Opportunity requirements as set forth in these Contract Documents. In the performance of this Contract, Contractor and its subcontractors shall not unlawfully discriminate, harass or allow harassment, against any employee or applicant for employment because of sex, gender, gender identity, gender expression, race, color, ancestry, religious creed, national origin, physical disability (including HIV and AIDS), mental disability, medical condition (cancer), genetic information, marital status, age (over 40), sexual orientation, or military and veteran status. In addition, Contractors and subcontractors shall not unlawfully deny any of their employees family care leave or discriminate against them on the basis of having to use family care leave.

VTA affirms that disadvantaged and small business enterprises will be afforded full opportunity to submit Bids. Refer to **Appendix C Business Diversity Policy and Requirements** for business diversity requirements.

### 2.3. Description of the Contracting Process

#### 2.3.1. General Process

The period between issuance of the Invitation for Bid and issuance of a Notice to Proceed consists of the steps listed below:

##### Bid Process

- Invitation for Bid posted and Pre-Bid Meeting
- Bid opening and submittal of Bid Forms
- VTA determines successful Bidder and issues a Notice of Recommended Award

#### Award Process

- Upon VTA's approval of the award of the Contract, VTA issues Notice of Award and Successful Bidder provides Contract forms and documents to VTA (see **Section 2.3.2 Notice of Award**)
- VTA reviews submitted forms and approves Performance Bond, Payment Bond, Insurance Certificates, and other documents as requested by VTA.

#### Contract Execution and Notice to Proceed

- Execution of Contract by VTA
- VTA issues a Notice to Proceed

### **2.3.2. Notice of Award**

After Bids are opened at the time and place stipulated, the Contract will be awarded to the lowest responsive and responsible Bidder ("Successful Bidder"), based on the "Total Bid Price" (as defined in **Section 2.5 Definitions**) subject to VTA's right to reject any or all Bids. No Bidder may withdraw its Bid for the period of days stipulated on the Bid Form after the date set for the Bid Opening. The Bid will be subject to acceptance by VTA during this period.

Promptly upon VTA's approval of the award of the Contract, the Contracts Office will issue a "Notice of Award" letter to the Successful Bidder. Included with the NOA will be two (2) originals of the **Construction Agreement** and one (1) original **Performance Bond** and **Payment Bond**.

Within **six (6) working days** from the date of NOA, the Successful Bidder must return the following documents:

#### Documents

#### For additional information, reference the following:

- |   |   |
|---|---|
| • Executed copies of the Contract                         |   |
| • The Performance Bond                                    | Section 6.3                             |
| • The Payment Bond  | Section 6.3                             |
| • Listing of Subcontractors, Suppliers and Subconsultants | Section 4                               |
| • Certificates of Insurance                               | Appendix A                              |
| • Tax Forms   | Section 2.4 State and Federal Tax Forms |

Refer to **Section 3 Instructions to Bidders** and **Section 6 Special Conditions** for additional information about each of the requirements listed above.

### **2.3.3. Bid Security**

- (a) **Forfeiture of Bid Security.** Failure of the Successful Bidder to whom the NOA was issued to sign the Construction Agreement and submit all of the documents required within **six (6) working days** will be just cause for the annulment of the award and forfeiture of Bidder's security.
- (b) **Return of Bid Security.** If the Bid is not accepted by VTA within the period of days stipulated on the Bid Form after the date set for Bid Opening, or if the Successful Bidder executes and delivers to VTA the required documents, then any certified or cashier's check will be returned to all Bidders.



#### 2.3.4. Executed Contract and Notice to Proceed

(a) After delivery by the Successful Bidder of two (2) signed original Construction Agreements and all required submissions as stipulated above, VTA will sign the Construction Agreement. No agreement between VTA and Contractor is in effect until VTA executes the Construction Agreement.

(b) VTA will issue a Notice to Proceed promptly following execution of the Construction Agreement, Contractor's compliance with the requirements set forth in Section 2.3, and VTA review of Contractor's Injury and Illness Prevention Program (IIPP) and Site Specific Safety Plan (SSSP). Requirements related to Contractor's IIPP and SSSP are further described in Appendix Q.

As a prerequisite for issuance of Notice to Proceed, Contractor must also submit the following:

For information only (provided on company letterhead, or on forms to be provided by VTA):

1. Names and titles of those persons authorized to sign contract Change Orders and daily Extra Work Orders (EWO's).
2. Names of the superintendent(s) and forepersons who will oversee the various phases of construction.
3. numbers of two of Contractor's key personnel who can be contacted 24-hours-a-day in case of an emergency.
4. Name of Contractor's Safety Officer, with documentation that the designated Safety Officer has completed competent person training in all aspects of the Site-Specific Work Plan (SSWP).
5. Name and title of the person(s) responsible for developing, implementing, and enforcing infectious disease (COVID-19) safety plans and safety measures.
6. Name and title of person(s) designated to develop and implement the Quality Assurance Plan.
7. Name and title of the persons designated to be the Equal Employment Opportunity Officer for the prime contractor and all subcontractors.
8. Name, Address, Telephone Number and division of work for each subcontractor listed in the Bid and Contract Forms.
9. Contractor's Injury and Illness Prevention Program (IIPP) consistent with the requirements in Appendix Q.
10. Notices of materials to be used, for both Contractor and its subcontractors. Forms for this purpose will be provided with the follow-up-letter to Notice of Award. These notices must be submitted sufficiently in advance to permit proper inspection and testing of materials to be used, prior to their use in the field.

For VTA review in accordance with Section 6.6.2:

1. Site-Specific Safety Plan (SSSP) consistent with the requirements in Appendix Q.
2. Schedule of Contractor's proposed construction operations in accordance with **Special Conditions Section 6.21 Progress Schedule.**

3. Schedule of Values for detail breakdown of pay items in accordance with **General Conditions Section 7.59 Progress Payment**, and **Technical Specifications Section 01 13 92 Schedule of Values**.
4. A listing of Contractor's and its subcontractor's wage rates, containing trades, classifications, and hourly rates of pay for workers who are to be employed in the construction of the project.
5. Erosion and Sediment Control Action Plan Element (ESCAPE).

Contractor shall commence performance of the Work after receipt of the Notice to Proceed, and must continuously and diligently prosecute the Work to completion on or before the time or times set forth in **Section 6 Special Conditions** herein. Regardless of the date of the Notice to Proceed, the first day charged will be the **20<sup>th</sup> calendar day** following the date of the NOA. Should the first charged day fall on a Friday or weekend or holiday, the following working day will be the first day charged.

Contractor will neither enter upon nor occupy VTA property or commence any materials fabrication prior to receiving the Notice to Proceed. Any Work performed or expenses incurred by Contractor prior to Contractor's receipt of Notice to Proceed will be entirely at Contractor's risk.

#### **2.4. State and Federal Tax Forms**

Federal tax form W-9 and California state tax forms, either FTB Form 587 or Form 590, are required to be submitted annually. If the Successful Bidder has submitted these forms within the last 12 months, please so indicate when returning the Contract forms and other documents for execution by VTA.

#### **2.5. Definitions**

Certain terms used in this IFB have the meaning set forth below.

**"Bid Add Alternates"** are additional items of Work that may be awarded as part of the Contract if the Bids come within the budget specified in the Contract.

**"Bidder(s)"** means the respondent submitting a Bid in response to the Invitation for Bid.

**"Construction Agreement"** or **"Maintenance Agreement"** has the meaning as specified in Contract Form 1.

**"Contract Documents"** means documents for this project that specify the requirements of the Work to be performed inclusive of addenda, the terms of the contract between VTA and the successful Bidder inclusive of addenda, and the details of the bidding procedure.

**"Contracts Office"** or **"PCMM Office"** refers to the Procurement, Contracts and Materials Management offices of VTA, located at 3331 N. First Street, Building A, in San José, CA

**"Day", "working day" and "holiday"** have the meaning as specified in **Section 6.22 References to Days**.

**"DIR"** means California Department of Industrial Relations

**"IFB"** means Invitation for Bids

**“NOA”** means Notice of Award

**“Pre-Qualification”** means the review and scoring of qualifications of potential Bidders in which such factors as financial capability, reputation, and management are considered in order to develop a list of qualified firms who may then be allowed to submit a Bid.

**“Successful Bidder”** means the Bidder that has submitted the lowest responsible and responsive bid, including holding the appropriate licenses as required by the Invitation for Bids.

**“Total Bid Price”** is the sum of the Bidder’s Total Base Bid and all Bid Add Alternates (if applicable). In the case of multiple year contracts, the Total Bid Price represents the sum of the Bid amount for each year of the Contract.

**“Total Contract Price”** is the value of the awarded Contract, as determined by adding Contractor’s Total Base Bid and accepted Bid Add Alternates (if applicable). In the case of Multiple Year Contracts, the Total Contract Price represents the sum of the Bid amount for each year of the Contract.

**“Track Zone”** means an area within six (6) feet of the closer rail on both sides of the track.

**“VTA”** means Santa Clara Valley Transportation Authority

**“Work”** means the work to be performed as specified in these Contract Documents.

**“Worksite”** means the site(s) upon which the Work will be performed or an area to be occupied by the Work and all adjacent and other related areas occupied or used by Contractor or his subcontractors. For maintenance contracts, this includes storage areas, buildings, staging areas, and areas for the production, procurement, storage, and disposal of materials and related equipment. The use of the word “job site” or “site” in these Contract Documents is synonymous with “Worksite.”

*[This Page Intentionally Left Blank]*

## SECTION 3 INSTRUCTIONS TO BIDDERS

### 3.1. Pre-Bid Meeting

A pre-Bid meeting will be held at the time and place set out in **Section 1.10 Pre-Bid Meeting and Project Site Tour**. The purpose of this meeting is to inform prospective Bidders and potential subcontractors of subcontracting and material supply opportunities and to receive comments and questions regarding the Work and the Contract Documents from attendees. Representatives of VTA will be present to discuss:

- Participation of minority, women, disabled veterans, LGBT owned businesses, small businesses and/or disadvantaged businesses.
- Equal Employment Opportunity requirements.
- Coordination of the Work.
- Community relations
- Other subjects as appropriate.

If participation goals are stipulated in this Contract, attendance of prospective Bidders at this meeting may be one consideration of the reasonable good-faith efforts made to obtain the specified participation goal. Refer to **Appendix C Business Diversity Policy and Requirements** for additional information.

### 3.2. Examination of the Contract Documents

Each Bidder must carefully examine the Contract Documents and become thoroughly familiar with the terms and conditions contained therein prior to the Bid Opening date. The Bid submitted must include a sum to cover the cost of all items necessary to perform the Work. No allowance of any kind will be made to any Bidder because of lack of such examination or knowledge. The submittal of a Bid is conclusive evidence that the Bidder has made such an examination.

### 3.3. Examination of Site and Existing Conditions

In addition to examination of the Contract Documents, each Bidder must, prior to the Bid Opening, become fully informed regarding all existing and expected site conditions which might in any way affect the cost or the time of performance of the Work. Any failure of the Bidder to fully investigate the Worksite and inform itself of existing and anticipated site conditions does not relieve such Bidder from responsibility for estimating properly the cost or difficulty of performing the Work.

A tour may be conducted in order to familiarize Bidders with the Worksite. Refer to **Section 1.10 Pre-Bid Meeting and Project Site Tour**.

### 3.4. Addenda to Contract Documents

VTA reserves the right to make changes in the Contract Documents as it may deem appropriate up to the time set for Bid Opening. Any and all changes in the Contract Documents will be made by one or more written addenda, which will be issued by VTA to all prospective Bidders who have registered and downloaded the Contract Documents at VTA's website.

If such addenda require changes in quantities or might affect the prices bid, or both, the date set for Bid Opening may be postponed by such number of days as in the opinion of VTA will enable Bidders to revise their Bids. In any case, Bid Opening will be at least **5 working days** after the issue date of the last

addendum and that addendum will include an announcement of the new date, if applicable, for the Bid Opening.

Failure to acknowledge receipt of all addenda may cause the Bid to be considered non-responsive to the Contract Documents. Bidder certifies that the Contract Documents and addenda thereto have been thoroughly read and that there are no misunderstandings as to the meaning, purpose, or intent of any provision in the Contract Documents as modified by those addenda.

### **3.5. Prevailing Wage Requirements**

**All Bidders bidding on this Work (and any listed subcontractors carrying out covered work) must be registered with the DIR at the time of Bid Opening, as further set forth at Section 7.8 Labor Provisions.**

Listing of subcontractors is as follows:

- Bid Form 4 and Bid Form 5, in accordance with the instructions provided in those bid forms.
- All subcontractors of every tier, for any dollar amount, must be listed on Contract Form 4 "Listing of Subcontractors, Suppliers and Subconsultants" prior to issuance of the Notice to Proceed.
- Any subcontractors, for any dollar amount, added to the project after the Notice to Proceed requires notification to VTA.

Pursuant to appropriate sections of the Labor Code of the State of California, the Director of the DIR has ascertained the general prevailing rate of wages (which rate includes employer payments for health and welfare, vacation, pension, and similar purposes) applicable to the Work for straight time, overtime, Saturday, Sunday and holiday work. Contractor must post a copy of the prevailing wage rates at the Worksite or material staging area. Contractor must submit certified payrolls and labor compliance documentation electronically, via a web-based system, accessed on the internet at the address(es) provided by VTA. The current web based system utilized by VTA is LCPtracker.

Workers employed in the Work must be paid at the rates at least equal to the prevailing wage rates specified by VTA. If Contractor uses a craft or classification not shown on the prevailing wage determinations, Contractor may be required to pay the wage rate of that craft or classification most closely related to it as shown in the general determinations effective at the time of Contract award.

In the performance of the Work, Contractor and all subcontractors **carrying out covered work** will be responsible for compliance with California Labor Code Sections 1776 (Payroll records, retention, inspection, noncompliance penalties, rules and regulations) and 1777.5 (Employment of registered apprentices, wages, standards, number, apprenticeable craft or trade, exemptions, contributions).

### **3.6. Workers Compensation**

In addition to the bid forms described in this Section 3 Instructions to Bidders, by signing and submitting this Bid, the Bidder is providing the certification set out below.

Bidder hereby certifies that it is aware of the provisions of California Labor Code §3700, which requires every employer to be insured against liability for workers' compensation or to undertake self-insurance in accordance with the provisions of that code, and that Bidder will comply with such provisions before commencing the performance of the Work.

### **3.7. Reserved**

### **3.8. Business Diversity**

#### **3.8.1. Goal**

A participation goal for Small Business Enterprises (“SBEs”) has been established for this Contract as detailed in Section 1.7 Business Diversity Program of the Invitation for Bid.

#### **3.8.2. Business Diversity Policy and Requirements**

Bidders must comply with VTA's Small Business Enterprises Policy and Requirements, as set out in **Appendix C Business Diversity Policy and Requirements**.

A Bidder who fails to achieve the SBE participation goal and who fails to demonstrate sufficient good-faith efforts to meet such goal will be deemed “non-responsive” and therefore ineligible for award of the Contract.

Bid Form 4, Bid Form 5, and Good Faith Efforts (if the SBE goal is not achieved) must be submitted in accordance with Section 3.10 Bid Forms and Appendix C Business Diversity Policy and Requirements. If Bidder is also a SBE firm, then list the bidder/contractor name on the Bid Form 4 and Bid Form 5.

In order to be counted for SBE credit, all firms must be identified on Bid Form 4 as certified by VTA’s Office of Business Diversity Program (OBDP) or DBEs certified with the California Unified Certification Program (CUCP), or accepted by OBDP at the time of Bid.

It is the Bidder’s sole responsibility for verifying subcontractor certification as a SBE to VTA. Bidders may search a list of VTA's certified SBE firms at <http://www.vta.org/about-us/doing-business-with-vta-search-for-sbes>. VTA’s SBE application is available at <http://www.vta.org/About-Us/Inside-VTA/Small-Business-Enterprise-Program>.

The SBE Goal Achieved in the approved Bid Form 4 equates to a commitment from Contractor; Contractor must meet this commitment.

### **3.9. Preparation of Bid**

The Bidder must prepare its Bid in strict accordance with all of the requirements of the Contract Documents and any addenda thereto. In order to receive consideration, all Bids must comply with the following instructions:

#### **3.9.1. Submit Bid on Form Provided**

Bids must be submitted on the forms provided in these Contract Documents in signed original. Bids submitted in any other form may be considered nonresponsive and rejected.

Blank spaces in each Bid form must be properly filled in by indelible means, and the phraseology thereof must not be changed. Any conditions or limitations made to the items mentioned therein may be cause for rejection. Alterations by erasure or interlineation must be explained or noted in the Bid over the signature of the Bidder.

No modification of a Bid Form will be considered.

### **3.9.2. Prices, Taxes and Applicable Fees in the Bid**

Bids must include full compensation for furnishing all labor, material, tools, and equipment and doing all the Work complete in place in accordance with the requirements of the Contract. Bid prices must include all applicable taxes, freight charges and other applicable fees of any kind.

Contractor will be responsible for assessing any and all applicable taxes related to the purchase of or installation of materials used on a VTA project and will, for purposes of determining transaction or use tax liability, use the Worksite as the place where “engaged in business”.

### **3.9.3. Sealed Envelope**

All Bids must be enclosed in a sealed envelope bearing the Contract number, the title of the Project, the date and hour of the opening, and the name of the Bidder. Bids must be addressed to the name and location as specified in **Section 1.4. Submittal Location and Deadline**. It is the sole responsibility of the Bidder to see that its Bid is received in a timely manner.

## **3.10. Bid Forms**

Bids must include the Bid Forms as outlined in the cover page of Section 4 Bid Forms. The sections that follow provide specific requirements for the Bid Forms to be submitted.

### **3.10.1. Bid Form 1: Schedule of Quantities and Prices**

The Bidder must complete and submit **Bid Form 1** in its entirety as instructed in **Bid Form 1**.

The quantities given in the Schedule of Quantities and Prices for which unit prices are asked to be Bid are approximate only, being given as a basis for the comparison of Bids, and VTA does not, expressly or by implication, represent that the actual quantities required will correspond therewith, but reserves the right to increase or decrease or omit entirely the quantity of any class or portion of the Work, or materials required for all or any portion of the Work, as VTA may deem necessary or advisable.

On all Bid items for which Bids are to be received on a unit price basis, the unit price for all items must be shown, as well as the extended price (unit price multiplied by the number of units shown on **Bid Form 1**) for each Bid item. If there is a discrepancy between unit prices and extended price for any Bid item, the unit price multiplied by the number of units will prevail. In the event of a discrepancy between the sum of the extended prices for all Bid items and the Total Bid Price, the sum of the extended prices of all items will prevail. The sum of extended prices on all Bid items and the Total Bid Price must be calculated to two (2) decimal places.

### **3.10.2. Bid Form 2: Bid Security Form/ Bidder’s Bond**

At the Bid Opening, each Bid must be accompanied by **Bid Form 2** and a certified or cashier’s check, or a Bidder’s Bond in the sum of not less than **5% of the Total Bid Price** (as defined in **Section 2.5 Definitions** and as further represented below) and said checks or bond must be made payable to the order of the Santa Clara Valley Transportation Authority.

### **3.10.3. Bid Form 3: Designation of Subcontractors**

At the Bid Opening, each Bid must be accompanied by **Bid Form 3**. If there are no subcontractors, Bidder must write “No Subcontractors” on the form. If there are subcontractors, follow the instructions on **Bid Form 3**.



#### **3.10.4. Bid Form 4: Listing of SBE Contractor or Subcontractors**

At the Bid Opening, the Bidder must complete and submit **Bid Form 4** in its entirety as instructed in **Bid Form 4**.

#### **3.10.5. Bid Form 5: Supplemental Contractor and Subcontractor Information**

Bid Form 5 is to be submitted no later than 5 PM on the 2<sup>nd</sup> working day after the Bid Opening. The Bidder must complete and submit Bid Form 5 in its entirety as instructed in Bid Form 5.

#### **3.10.6. Bid Forms 6 to 7 and 10**

At the Bid Opening, each Bid must be accompanied by the following Bid Forms:

- (a) Bid Form 6 – Litigation Disclosure
- (b) Bid Form 7 – Reserved
- (c) Bid Form 10 – References Bidder must provide the requested information in Bid Form 10 for the last three completed projects of similar scope, size and dollar value.

#### **3.10.7. Bid Forms 8 to 9**

At the Bid Opening, each Bid must be accompanied by the following Bid Forms:

- (a) Bid Form 8 – Non-Collusion Declaration
- (b) Bid Form 9 – Public Contract Code Statements

### **3.11. Bids and Bid Opening**

Bids will be opened and publicly read aloud by the Contract Administrator at the Bid Opening. The following conditions may apply to the bids.

#### **3.11.1. Late Bids**

Bids received after the Bid Opening will not be considered. Late Bids will be returned unopened.

#### **3.11.2. Withdrawal of Bid**

Any Bidder may withdraw its Bid, either personally or by a written request by a duly authorized representative, at any time prior to the scheduled time for Bid Opening. However, no Bidder may withdraw its Bid for a period of **120 calendar days** after the Bid Opening. Bidder's attention is directed to the provisions of the Public Contract Code Sections 5100 to 5110 regarding relief of Bidders.

#### **3.11.3. Conditional Bids**

Conditional Bids, or those which take exception to the Contract Documents, will be considered non-responsive and will be rejected.

#### **3.11.4. Bidders Interested in More than One Bid**

No entity will be allowed to make or file or be interested as a principal in more than one Bid for the same Work, unless alternate Bids are called for. However, a person, firm or corporation submitting a sub-bid to a Bidder, or who has quoted prices on materials to a Bidder, is not thereby disqualified from submitting a sub-bid or quoting prices to other Bidders or from being a principal Bidder for the same Work.

### **3.11.5. Single Bid Response**

If only one Bid is received in response to the Invitation for Bid, a detailed cost proposal will be required of the single Bidder. A cost/price analysis and evaluation and/or audit will be performed of the cost proposal in order to determine if the price is fair and reasonable.

### **3.12. Award or Rejection of Bids**

#### **3.12.1. Award Process**

Award of the Contract to the Successful Bidder will be made within **120 calendar days** after the Bid Opening ("Initial Execution").

If the first Bidder selected as a Successful Bidder refuses or fails to execute the Contract within the Initial Execution period, VTA may award the Contract to the second-ranked Successful Bidder selected as provided herein and such an award, if made, will be made within **30 calendar days** after VTA notifies the second-ranked Successful Bidder of the first-ranked Successful Bidder's failure to execute the Contract ("Secondary Execution").

If the second-ranked Successful Bidder refuses or fails to execute the Contract within the Secondary Execution period, VTA may award the Contract to the third-ranked Successful Bidder selected as above provided and such an award, if made, will be made within **30 additional calendar days**.

If necessary, the same procedure may be utilized by VTA for awarding the Contract to subsequent Successful Bidders. The periods of time specified above within which the award of Contract may be made will be subject to an extension for such further period as may be agreed in writing between VTA and the Bidder concerned. VTA reserves the right to reject any or all Bids and to waive any informality in the Bids or in the Bid process. Obvious cases of Bid imbalancing may be cause for rejection.

### **3.13. Basis of Award**

Bids will only be accepted from those Bidders who have been pre-qualified as required for this Project. The fact of pre-qualification or any pre-qualification rating will not preclude VTA from a post-Bid consideration and determination of whether a Bidder has the quality, fitness, capacity and experience to satisfactorily perform the proposed Work, and has demonstrated the requisite trustworthiness. The criteria for determining the Successful Bidder will include the Bidder's responsiveness to the requirements of the Contract Documents, Bidder's responsibility, and price.

### **3.14. Responsibility Hearing**

Before being declared non-responsible, a Bidder must be notified of the proposed determination of non-responsibility, served with a summary of the information upon which VTA is relying and provided with an opportunity to be heard in accordance with applicable law. At the responsibility hearing, the Bidder will be allowed to rebut adverse information and to present evidence that it has the necessary quality, fitness and capacity to perform the Work.

The Bidder must exercise its right to request a hearing within **5 calendar days** after receipt of such notice. Failure to submit a written request for a hearing within the time frame set forth in this Section, will be deemed a waiver of the right to such a hearing and the awarding authority may proceed to determine

whether or not the award of the contract should be made to another Bidder or whether or not the Bidder is non-responsible for this and future contracts.

The determination by VTA that the Bidder is non-responsible will be final and constitute exhaustion of the Bidder's administrative remedies.

### **3.15. Bidder Review and Protest Procedures**

The following procedures must be used by Bidders seeking review of the Contract Documents or the contracting process:

#### **3.15.1. General Information**

A Bidder may discuss the Contract Documents with VTA. Such discussions do not, however, relieve Bidders from the responsibility of submitting written, documented requests as required by these procedures. Bidder requests and protests must be addressed to the Contracts Office, Santa Clara Valley Transportation Authority, 3331 North First Street, San José, CA 95134-1927, Attention: Procurement, Contracts & Materials Manager, and clearly marked "Bid Protest" on the outside of the envelope. VTA will decide the merits of the request or protest and render a determination. The protest resolution record will be provided to the protesting Bidder upon request.

#### **3.15.2. Pre-Bid Opening Protests**

Prior to Bid Opening, a Bidder may submit to VTA protests regarding the procurement process or items in the Contract Documents. Any such protest must be received by VTA, in writing, not fewer than **ten (10) working days** before the date of scheduled Bid Opening. Any protest must be fully supported with technical data, test results, or other pertinent information as evidence that the protest should be upheld.

VTA will make a determination of the merits of each Bidder protest. That written determination will be mailed or otherwise furnished to all Bidders.

#### **3.15.3. Post Bid Opening Protests**

Protests based upon alleged improprieties in the procurement process that can only be apparent after Bid Opening or the closing date for receipt of additional post Bid Opening documentation, must be filed no later than **five (5) working days** following the issuance of a Notice of Recommended Award. Protests must contain a statement of the grounds for protests and supporting documentation. Final VTA decision on the protest will be mailed or otherwise furnished to both the Successful Bidder and protesting Bidder prior to award of the Contract.

*[This Page Intentionally Left Blank]*

## SECTION 4 BID FORMS

These forms are designed to contain essential information concerning the Bidder and the Bid, and must be completed such that they can be read. If any of the completed forms are illegible, VTA may, at its option, declare the entire Bid unresponsive.

- Bid Form 1** Bid Form, Schedule of Quantities and Prices, Contractor Information
- Bid Form 2** Bidder's Bond  
Note: Form must be acknowledged by a notary
- Bid Form 3** Designation of Subcontractors
- Bid Form 4** Listing of SBE Contractor or Subcontractors
- Bid Form 5** Supplemental Contractor and Subcontractor Information
- Bid Form 6** Litigation Disclosure
- Bid Form 7** Reserved
- Bid Form 8** Non-Collusion Declaration
- Bid Form 9** Public Contract Code Statements
- Bid Form 10** References and Previous Experiences

*[This Page Intentionally Left Blank]*

**BID FORM 1**  
**BID FOR CONTRACT C19123**

This form must be submitted with the Bid.

FROM: \_\_\_\_\_  
(BIDDER'S NAME)

TO: THE SANTA CLARA VALLEY TRANSPORTATION AUTHORITY  
STATE OF CALIFORNIA

In compliance with your Invitation for Bid for this project, the undersigned Bidder, being thoroughly familiar with the terms and conditions of the Contract Documents, hereby proposes and agrees to perform fully the Work within the time stated and in strict accordance with the Contract Documents.

The Bidder hereby acknowledges receipt of the following addenda to the Contract Documents:

Addendum No. \_\_\_\_\_ Dated \_\_\_\_\_

Addendum No. \_\_\_\_\_ Dated \_\_\_\_\_

Addendum No. \_\_\_\_\_ Dated \_\_\_\_\_

Addendum No. \_\_\_\_\_ Dated \_\_\_\_\_

Addendum No. \_\_\_\_\_ Dated \_\_\_\_\_

Addendum No. \_\_\_\_\_ Dated \_\_\_\_\_

FAILURE TO ACKNOWLEDGE RECEIPT OF ALL ADDENDA MAY CAUSE THE BID TO BE CONSIDERED NON-RESPONSIVE. BIDDER CERTIFIES THAT IT HAS READ AND UNDERSTANDS THE CONTRACT DOCUMENTS AND ADDENDA AND THE MEANING, PURPOSE AND INTENT OF EVERY PROVISION THEREIN.

Bidder hereby incorporates by reference all provisions of the Contract Documents.

**CONTINUED ON NEXT PAGE →**

**BID FORM 1 (continued)**  
**Schedule of Quantities and Prices**

The prices quoted below include all applicable taxes, fees, permits, delivery and other charges as required.

If the Contract includes cleanup, please note that there is no separate payment item for "Cleanup"; therefore Bidder shall consider and include this in the various items of Work on the Schedule of Quantities and Prices.

**BIDDER'S NAME:** \_\_\_\_\_

(F)	Bid Item	Reference	Description	Unit	Qty.	Total
			All labor, equipment, services and material for completion of the work described in the Contract Documents.	Lump Sum	Lump Sum	\$
<b>TOTAL BID PRICE:</b>						<b>\$</b>

**CONTINUED ON NEXT PAGE →**



**BID FORM 1 (continued)**

**Signature Page**

**A. ENTER FULL AND CORRECT NAME OF BIDDER:**

Firm Name: \_\_\_\_\_

**B. ENTER BUSINESS ADDRESS**

Street Address: \_\_\_\_\_

City, State, ZIP: \_\_\_\_\_

Phone #: \_\_\_\_\_ Email: \_\_\_\_\_

**C. CALIFORNIA CONTRACTOR'S LICENSE**

Number: \_\_\_\_\_

Class: \_\_\_\_\_

Expires: \_\_\_\_\_

**D. BIDDER INFORMATION**

Is this firm at least 51% owned by minorities or women?	<input type="checkbox"/> Yes <input type="checkbox"/> No (check one)
If yes, check the following primary ownership group:	<input type="checkbox"/> Asian Pacific <input type="checkbox"/> Asian Indian <input type="checkbox"/> Native American
	<input type="checkbox"/> Black <input type="checkbox"/> Hispanic <input type="checkbox"/> Caucasian <input type="checkbox"/> Other _____
Check gender of owner(s):	<input type="checkbox"/> Male <input type="checkbox"/> Female

**E. LIST PRINCIPALS**

The names of all persons as principals interested in the foregoing bid are as follows:

(IMPORTANT NOTICE: If Bidder or other interested person is a corporation, give legal name of corporation, and names of the President and Secretary thereof; if a partnership, give name of the firm, also names of all individual partners composing firm; if Bidder or other interested person is an individual, give first and last names in full. If a Bidder is a joint venture, supply the above information for each joint venture partner.) Attach additional pages if needed.

\_\_\_\_\_  
\_\_\_\_\_

**F. SIGN AND DATE**

The person signing this Bid Form for the Bidder certifies that he or she is authorized by the Bidder to do so and that the Bidder is bound contractually by that signature.

Signature: \_\_\_\_\_

Name (print): \_\_\_\_\_

Title: \_\_\_\_\_

Date: \_\_\_\_\_

*[This Page Intentionally Left Blank]*

**BID FORM 2  
BIDDER'S BOND**

KNOW ALL PEOPLE BY THESE PRESENTS: That

**WHEREAS** the undersigned, \_\_\_\_\_

as Principal and \_\_\_\_\_

as Surety, are held and firmly bound unto the Santa Clara Valley Transportation Authority, a political subdivision of the State of California (hereinafter called "VTA") in the penal sum of **5%** of the **Total Bid Price** (as defined in **Section 2.5 Definitions**) of the Principal above named, submitted by said Principal to VTA for the work described below, for the payment of which sum in lawful money of the United States, well and truly to be made, we bind ourselves, our heirs, executors, administrators and successors, jointly and severally, firmly by these presents.

The condition of this obligation is such that a bid to VTA for performance of that certain construction described as

**Cerone Division Boiler & Propane Tank Replacement  
Contract C19123**

("Bid") has been submitted by Principal to VTA.

**NOW THEREFORE**, if the aforesaid Principal shall not withdraw said Bid within **120 calendar days** after said opening, and shall within the period specified therefore, or if no period be specified, within **six (6) working days** after the prescribed forms are presented to Principal for signature, enter into a written contract with VTA in the prescribed form in accordance with the Bid as accepted ("Contract"), submit the required insurance certificates and **a Performance Bond in the amount of 100% of the Total Contract Price** to guarantee faithful performance of the Work under the Contract and **a Payment Bond in the amount of 100% of the Total Contract Price** to guarantee payment for labor and materials, as required by law, or in the event of the withdrawal of said Bid within the period specified or the failure to enter into such Contract and give such bonds and insurance within the time specified, if the Principal shall pay VTA the difference between the amount specified in said Bid and the amount for which VTA may procure the required work, if the latter amount be in excess of the former, together with all costs incurred by VTA in again calling for bids, should that become necessary, then the above obligation shall be void and of no effect, otherwise to remain in full force and effect.

Surety, for value received, hereby stipulates and agrees that no change, extension of time, alteration or addition to the terms of the Contract on the call for Bids, or to the work to be performed thereunder, or the specifications accompanying the same, shall in any way affect its obligation under this Bond, and it does hereby waive notice of any such change, extension of time, alteration or addition to the terms of said Contract or the call for bids, or to the work, or to the specifications.

In the event suit is brought upon this bond by VTA and judgment is recovered, the Surety shall pay all costs incurred by VTA in such suit, including a reasonable attorney's fee to be fixed by the court in accordance with applicable statutory law.

Cerone Division Boiler & Propane Tank Replacement  
Contract C19123

IN WITNESS WHEREOF, we have hereunto set our hands and seals on this \_\_\_\_\_ day of \_\_\_\_\_, 20\_\_\_\_\_.

**PRINCIPAL**

**SURETY**

\_\_\_\_\_  
(Company)

\_\_\_\_\_  
(Company)

\_\_\_\_\_  
(Signature)

\_\_\_\_\_  
(Signature)

\_\_\_\_\_  
(Name – Please Print)

\_\_\_\_\_  
(Name – Please Print)

\_\_\_\_\_  
(Title)

\_\_\_\_\_  
(Title)

**NOTE: Signatures of those executing for Surety must be acknowledged by a Notary.**

**NOTE TO SURETY COMPANY:**

The following form of acknowledgement should be used. If any other form of acknowledgement is used, there must be submitted a certified copy of unrevoked resolution of authority for the attorney-in-fact.

**SURETY COMPANY ATTORNEY-IN-FACT**

State of California )  
County of \_\_\_\_\_ )

On \_\_\_\_\_, before me, the undersigned, a Notary Public in and for the State, personally appeared \_\_\_\_\_, known to me to be the duly authorized attorney-in-fact of the corporate Surety named in the within instrument, known to me to be authorized to execute that instrument on behalf of said corporation, known to me to be the person whose name is subscribed to such instrument as the attorney-in-fact of said corporation, and acknowledged to me that he (she) subscribed the name of said corporation thereto as Surety, and his (her) own name as attorney-in-fact and that said corporation executed the same.

(SEAL)

WITNESS MY HAND AND OFFICIAL SEAL:

\_\_\_\_\_  
Notary Public for the State of California

Acknowledgement by attorney-in-fact must be attached.  
Corporate seals of Principal and Surety must be attached.

## BID FORM 3 DESIGNATION OF SUBCONTRACTORS

**IMPORTANT INFORMATION**

Bidder shall completely fill in the form below for each proposed subcontract in excess of one-half of 1 percent of Bidder's Total Bid Price, or in Bids for the construction of streets, highways, including bridges, in excess of one-half of 1 percent of the Bidder's Total Bid Price or \$10,000, whichever is greater, in compliance with the Public Contract Code of the State of California, Sections 4100-4114.

Additionally, Bidder must list below all subcontractors (regardless of the subcontractor's tier or subcontract amount) needed to show compliance to **Section 1.5 Licenses**.

**A. ENTER PRIME BIDDER INFORMATION**

1. Bidder Name: \_\_\_\_\_
2. Total Amount to be Subcontracted:     \$ \_\_\_\_\_
3. Total Percentage to be Subcontracted:     \_\_\_\_\_ %

**B. ENTER NAMES OF SUBCONTRACTORS OR LOWER-TIER SUBCONTRACTORS AS REQUIRED ABOVE**

SUBCONTRACTOR NAME	SUBCONTRACTOR'S ADDRESS	CONTRACTOR'S STATE LICENSE NUMBER	CONTRACTOR'S DIR REGISTRATION NUMBER	BID ITEM(S) & DESCRIPTION OF WORK
_____ _____ _____	_____ _____ _____	_____ _____ _____	_____ _____ _____	_____ _____ _____
_____ _____ _____	_____ _____ _____	_____ _____ _____	_____ _____ _____	_____ _____ _____
_____ _____ _____	_____ _____ _____	_____ _____ _____	_____ _____ _____	_____ _____ _____

Cerone Division Boiler & Propane Tank Replacement  
Contract C19123

---

SUBCONTRACTOR NAME	SUBCONTRACTOR'S ADDRESS	CONTRACTOR'S STATE LICENSE NUMBER	CONTRACTOR'S DIR REGISTRATION NUMBER	BID ITEM(S) & DESCRIPTION OF WORK
<hr/> <hr/> <hr/>	<hr/> <hr/> <hr/>	<hr/> <hr/> <hr/>	<hr/> <hr/> <hr/>	<hr/> <hr/> <hr/>
<hr/> <hr/> <hr/>	<hr/> <hr/> <hr/>	<hr/> <hr/> <hr/>	<hr/> <hr/> <hr/>	<hr/> <hr/> <hr/>
<hr/> <hr/> <hr/>	<hr/> <hr/> <hr/>	<hr/> <hr/> <hr/>	<hr/> <hr/> <hr/>	<hr/> <hr/> <hr/>
<hr/> <hr/> <hr/>	<hr/> <hr/> <hr/>	<hr/> <hr/> <hr/>	<hr/> <hr/> <hr/>	<hr/> <hr/> <hr/>
<hr/> <hr/> <hr/>	<hr/> <hr/> <hr/>	<hr/> <hr/> <hr/>	<hr/> <hr/> <hr/>	<hr/> <hr/> <hr/>
<hr/> <hr/> <hr/>	<hr/> <hr/> <hr/>	<hr/> <hr/> <hr/>	<hr/> <hr/> <hr/>	<hr/> <hr/> <hr/>



*[This Page Intentionally Left Blank]*



## BID FORM 4 LISTING OF SBE/DBE CONTRACTOR OR SUBCONTRACTORS

This form must be submitted with the Bid. Refer to instructions on Page 2 of this form when filling out this form.

**A. ENTER PRIME BIDDER INFORMATION**

- |                            |                            |
|----------------------------|----------------------------|
| 1. Bidder Name: _____      | 6. Email: _____            |
| 2. Street Address: _____   | 7. Preparer's Name: _____  |
| 3. City, State, ZIP: _____ | 8. Preparer's Title: _____ |
| 4. Phone #: _____          | 9. Signature: _____        |
| 5. Fax #: _____            | 10. Date: _____            |

**B. LIST SBE/DBE CONTRACTOR AND SUBCONTRACTORS:**

ENTERPRISE NAME (Column1)	ENTERPRISE NAICS CODE (Column2)	SBE/DBE (Column3)	CERTIFICATION NUMBER (Column4)	SUBCONTRACT /PO \$ AMOUNT (Column5)
_____ _____	____-____-____ ____-____-____	<input type="checkbox"/> SBE <input type="checkbox"/> DBE	_____	\$ _____
_____ _____	____-____-____ ____-____-____	<input type="checkbox"/> SBE <input type="checkbox"/> DBE	_____	\$ _____
_____ _____	____-____-____ ____-____-____	<input type="checkbox"/> SBE <input type="checkbox"/> DBE	_____	\$ _____
_____ _____	____-____-____ ____-____-____	<input type="checkbox"/> SBE <input type="checkbox"/> DBE	_____	\$ _____
_____ _____	____-____-____ ____-____-____	<input type="checkbox"/> SBE <input type="checkbox"/> DBE	_____	\$ _____
_____ _____	____-____-____ ____-____-____	<input type="checkbox"/> SBE <input type="checkbox"/> DBE	_____	\$ _____
_____ _____	____-____-____ ____-____-____	<input type="checkbox"/> SBE <input type="checkbox"/> DBE	_____	\$ _____
_____ _____	____-____-____ ____-____-____	<input type="checkbox"/> SBE <input type="checkbox"/> DBE	_____	\$ _____
_____ _____	____-____-____ ____-____-____	<input type="checkbox"/> SBE <input type="checkbox"/> DBE	_____	\$ _____

11. Bidder  has  has not (check one box) met SBE/DBE Participation Goal.

**C. SUBMISSION OF GOOD FAITH EFFORT (GFE) DOCUMENTATION:**

GFE documentation is required if Bidder's Goal Achieved is less than Participation Goal. Refer to the **Section 13.7 Good Faith Effort for documentation** to provide.

---

**FOR VTA USE ONLY – BIDDER SHOULD NOT COMPLETE THIS SECTION**

VTA OBDP certifies that all Business Enterprise certifications are valid and information on this form is complete and accurate.

**Signature:** \_\_\_\_\_

**Printed Name/Title:** \_\_\_\_\_

**Phone #:** \_\_\_\_\_

**Date Signed:** \_\_\_\_\_

## **INSTRUCTIONS FOR BID FORM 4**

Refer to these instructions when filling out Bid Form 4 or the Bid may be rejected.

**IMPORTANT:** Identify all SBE/DBE firms being claimed for credit, regardless of tier. The preparer indicated in Part A is providing written confirmation of each listed SBE/DBE.

### **PART A: ENTER CONTRACTOR INFORMATION**

- Line 1: Name of Bidder.  
Line 2 and 3: Address of Bidder.  
Line 4 and 5: Phone and Fax numbers of Bidder.  
Line 6: Email of Bidder.  
Line 7, 8 and 9: Printed name, title and signature of Bidder's Authorized Representative.  
Line 10: Date when the Form is signed.

### **PART B: LIST CONTRACTOR AND SUBCONTRACTORS**

- Column 1: Enter name and address of the certified SBE/DBE subcontractor, or enter Bidder's name if Bidder is an SBE/DBE.  
Column 2: Enter subcontractor/vender North America Industry Classification System ("NAICS") code(s). Ref. <https://www.census.gov/eos/www/naics/>.  
Column 3: Check one of the choices offered. The firm must be certified through an approved certifying agency.  
Column 4: Enter SBE (or BDE) certification number. An SBE/DBE must, at the time of Bid, be certified by VTA's Office of Business Diversity Program (OBDP) or SBEs/DBEs certified with the California Unified Certification Program (CUCP), or accepted by OBDP.  
Column 5: Enter SBE/DBE subcontract or purchase order amount of the work to be performed or service to be provided. See **Appendix C Business Diversity Policy and Requirements** to determine how to count the participation credit amount of SBE/DBE firms. A summary of that information is provided below:

**CREDIT FOR SBE/DBE VENDOR** of materials or supplies is **limited to 60%** of its expenditures for materials and supplies required under this Contract and obtained from an SBE/DBE regular dealer. Credit for SBE/DBE manufacturers is given at 100% toward the SBE/DBE Goal Achieved only where the SBE/DBE vendor manufactures or substantially alters the material prior to resale.

**CREDIT FOR SBE/DBE BROKERS** (Distributor or Representative) is limited to the fees and commissions of the amount paid. All other firms receive 100% credit, less work subcontracted by the SBE/DBE to non-SBE/non-DBE firms, towards the SBE/DBE Goal Achieved.

**CREDIT FOR SBE/DBE TRUCKING FIRMS** is limited to amount performed by the SBE/DBE own trucks and drivers and by certified SBE/DBE trucking subhaulers. An SBE/DBE trucking firm must itself own and operate at least one fully licensed, insured and operational truck used on the Contract.

Formula to calculate Goal Achieved:

$$\text{SBE/DBE Goal Achieved} = \frac{\text{Sum [SBE/DBE Credit Amount]}}{\text{Total Bid Price}} \times 100$$

- Line 11: Calculate the SBE (or DBE) Goal Achieved as per above formula, and check whether Bidder's has met SBE/DBE Participation Goal. This percentage must equal or exceed the SBE or (DBE) Participation Goal or else Bidder must demonstrate Good Faith Efforts to achieve the goal. VTA will utilize the values provided herein to calculate Bidder's SBE/DBE Goal Achieved. Such values must be consistent with the values found elsewhere in the Bid Documents, otherwise **Bidder may be considered nonresponsive**. The Successful Bidder's SBE/DBE Goal Achieved becomes the Contractor's committed SBE/DBE goal.

*[This Page Intentionally Left Blank]*

---

## BID FORM 5

### SUPPLEMENTAL CONTRACTOR and SUBCONTRACTOR INFORMATION

INSTRUCTION TO CONTRACTOR: This form must be filled out by the Contractor and their subcontractors. Contractors, please copy this form distribute to all your subcontractors. Contractor must complete and sign all the forms, including subcontractor forms in Section D below and submit the information to the VTA Contract Administrator for this contract.

#### A. ENTER CONTRACTOR/SUBCONTRACTOR INFORMATION

1. Firm Name: \_\_\_\_\_
2. Street Address: \_\_\_\_\_
3. City, State, ZIP: \_\_\_\_\_
4. Phone No.: (    ) \_\_\_\_\_
5. Email Address: \_\_\_\_\_

#### B. FIRM DEMOGRAPHICS

6. Check all that apply:

- DBE                       SBE                       Non-SBE/Non-DBE                       MWBE                       DVBE                       LGBTBE
- 

7. Ethnicity                       Asian                       Subcontinent Asian                       Native American                       Black  
 Hispanic                       Caucasian                       Other \_\_\_\_\_
- 

8. Age of Firm: \_\_\_\_\_                      9. Gender                       Male                       Female
- 

10. Firm Annual Gross Receipts                       Below \$500K                       \$500K to \$1M                       \$1M to \$4M  
(indicate bracket of income):                       \$4M to \$6M                       \$6M to \$13M                       Above \$13M
- 

#### C. FORM COMPLETED BY:

11. Form Completed by  
(print name and sign) \_\_\_\_\_
12. Date Signed \_\_\_\_\_

#### D. TO BE COMPLETED BY CONTRACTOR

13. CONTRACTOR: \_\_\_\_\_
14. If firm listed in section A is a subcontractor, was subcontractor selected for a subcontract or purchase for this Contract?                       Yes                       No
15. If yes, enter the dollar value of this subcontract or purchase: \$ \_\_\_\_\_

**INSTRUCTIONS FOR BID FORM 5**

This form is for data collection purposes, required by federal regulation 49 CFR 26.11.

ENTER CONTRACTOR/SUBCONTRACTOR INFORMATION:

Contractor will fill out Parts A -D.

Contractor needs to make copies for their subcontractors. Subcontractors will fill out Parts A – C and return to this contractor. Contractor will fill out Part D on the subcontractor’s form and submit to VTA.

**PART A: ENTER CONTRACTOR/ SUBCONTRACTOR INFORMATION**

Line 1 to Line 5: Enter contractor/subcontractor name, address, phone number, and email.

**PART B: FIRM DEMOGRAPHICS**

Line 6: Check all that apply. Make sure that firm is certified by an approved agency: California Unified Certification Program, VTA for SBE only (Small Business Enterprise), or DGS (Department of General Services)

Line 7: Enter firm owner’s ethnicity

Line 8: # of years firm has been in business

Line 9: Select firm owner’s gender

Line 10: Select firm’s annual gross receipts bracket.

**PART C: FORM COMPLETED BY:**

Line 11: Print and sign the name of the person filling out this form

Line 12: Enter date signed.

**PART D: TO BE COMPLETED BY CONTRACTOR**

Line 13: Enter contractor’s name

Line 14: If firm is a subcontractor that will be used on the contract, select Yes, otherwise select No

Line 15: If firm is being used on the contract, enter subcontract value

**BID FORM 6**  
**LITIGATION DISCLOSURE**

Bidder shall list and describe in detail all pending litigation, any litigation that has been closed in the past five years, and any pending investigations by the California Department of Industrial Relations in which Bidder's firm is or has been a party.

Include the following information:

- If your firm, or any of its owners or officers been convicted of a crime involving the awarding of a contract of a government construction project, or the bidding or performance of a government contract.
- If your firm or any of its owners, officers or partners ever been found liable in a civil suit or found guilty in a criminal action for making any false claim or material misrepresentation to any public agency or entity.
- If your firm or any of its owners, officers or partners ever been convicted of a crime involving any federal, state, or local law related to construction.
- If your firm or any of its owners, officers or partners ever been convicted of a federal or state crime of fraud, theft, or any other act of dishonesty.

**Pending Litigation**

---

---

---

**Litigation settled in the last five years**

---

---

---

**Pending DIR Investigations**

---

---

---

(Use additional sheets if necessary)

**SIGN AND DATE**

The person signing this Bid Form 6 for the Bidder certifies that he or she is authorized by the Bidder to do so and that the Bidder is bound contractually by that signature.

Signature: \_\_\_\_\_

Name (print): \_\_\_\_\_

Title: \_\_\_\_\_

Date: \_\_\_\_\_

*[This Page Intentionally Left Blank]*



**BID FORM 7**  
**CERTIFICATE OF BIDDER OCCUPATIONAL SAFETY AND HEALTH (OSH)**

Bidder certifies the following:

1. Bidder does not have serious and willful violations of Part 1 (commencing with Section 6300) of Division 5 of the Labor Code, during the past five-year period  
- or -  
Bidder is taking appropriate corrective action to prevent further violations of Part 1 of Division 5 of the Labor Code.
2. Bidder's workers' compensation experience modification ("ex-mod") factor is below 1.25  
- or -  
Bidder's ex-mod factor is 1.25 to 1.75 and Bidder is taking all appropriate action to reduce employee workplace injuries, illnesses and workers' compensation losses.
3. Bidder has an injury prevention program instituted pursuant to Section 3201.5 or 6401.7 of the Labor Code.

**SIGN AND DATE**

The person signing this Bid Form 7 for the Bidder certifies that he or she is authorized by the Bidder to do so and that the Bidder is bound contractually by that signature.

Signature: \_\_\_\_\_  
Name (print): \_\_\_\_\_  
Title: \_\_\_\_\_  
Date: \_\_\_\_\_

*[This Page Intentionally Left Blank]*

**BID FORM 8**  
**NON-COLLUSION DECLARATION**

State of California )  
 )  
County of \_\_\_\_\_ ) ss.

The undersigned declares:

I am the \_\_\_\_\_ of \_\_\_\_\_, the party making the  
foregoing Bid. (TITLE) (COMPANY)

The Bid is not made in the interest of, or on behalf of, any undisclosed person, partnership, company, association, organization, or corporation. The Bid is genuine and not collusive or sham. The Bidder has not directly or indirectly induced or solicited any other bidder to put in a false or sham bid. The Bidder has not directly or indirectly colluded, conspired, connived, or agreed with any bidder or anyone else to put in a sham bid, or to refrain from bidding. The Bidder has not in any manner, directly or indirectly, sought by agreement, communication, or conference with anyone to fix the Bid price of the Bidder or any other bidder, or to fix any overhead, profit, or cost element of the Bid price, or of that of any other bidder. All statements contained in the Bid are true. The Bidder has not, directly or indirectly, submitted his or her Bid price or any breakdown thereof, or the contents thereof, or divulged information or data relative thereto, to any corporation, partnership, company, association, organization, bid depository, or to any member or agent thereof, to effectuate a collusive or sham bid, and has not paid, and will not pay, any person or entity for such purpose.

Any person executing this declaration on behalf of a Bidder that is a corporation, partnership, joint venture, limited liability company, limited liability partnership, or any other entity, hereby represents that he or she has full power to execute, and does execute, this declaration on behalf of the Bidder.

I declare under penalty of perjury under the laws of the State of California that the foregoing is true and correct and that this declaration is executed on this \_\_\_\_\_ day of \_\_\_\_\_, 20\_\_\_\_  
at \_\_\_\_\_, \_\_\_\_\_.  
(CITY) (STATE)

**SIGN AND DATE**

Signature of Declarant: \_\_\_\_\_

Name (print): \_\_\_\_\_

*[This Page Intentionally Left Blank]*

**BID FORM 9**  
**PUBLIC CONTRACT CODE STATEMENTS**

There are three parts to this Bid Form. Complete the information in each part and sign the last page of this Bid Form.

**A. Public Contract Code Section 10285.1 Statement**

In accordance with Public Contract Code Section 10285.1 (Chapter 376, Stats. 1985), the Bidder hereby declares under penalty of perjury under the laws of the State of California that the Bidder

has       has not

been convicted within the preceding three years of any offenses referred to in that section, including any charge of fraud, bribery, collusion, conspiracy, or any other act in violation of any state or Federal antitrust law in connection with the bidding upon, award of, or performance of, any public works contract, as defined in Public Contract Code Section 1101, with any public entity, as defined in Public Contract Code Section 1100, including the Regents of the University of California or the Trustees of the California State University. The term "Bidder" is understood to include any partner, member, officer, director, responsible managing officer, or responsible managing employee thereof, as referred to in Section 10285.1.

Note: The Bidder must place a check mark after "has" or "has not" in one of the blank spaces provided.

The above Statement is part of the Bid. Signing this Bid Form on the signature portion thereof shall also constitute signature of this Statement. Proposers are cautioned that making a false certification may subject the certifier to criminal prosecution.

**B. Public Contract Code Section 10162 Questionnaire**

In accordance with Public Contract Code Section 10162, the Bidder shall complete, under penalty of perjury, the following questionnaire:

Has the Bidder, any officer of the Bidder, or any employee of the Bidder who has a proprietary interest in the Bidder, ever been disqualified, removed, or otherwise prevented from bidding on, or completing a federal, state, or local government project because of a violation of law or a safety regulation?

Yes       No

Note: Bidder must place a check mark after "Yes" or "No".

If the answer is Yes, explain the circumstances in the following space:

---

---

---

**C. Public Contract Code 10232 Statement**

In accordance with Public Contract Code Section 10232, Bidder, hereby states under penalty of perjury, that no more than one final unappealable finding of contempt of court by a federal court has been issued against Bidder within the immediately preceding two-year period because of Bidder's failure to comply with an order of a federal court which orders Bidder to comply with an order of the National Labor Relations Board.

Note: The above Statement and Questionnaire are part of the Bid. Signing this Bid Form on the signature portion thereof shall also constitute signature of this Statement and Questionnaire. Contractors are cautioned that making a false certification may subject the certifier to criminal prosecution.

---

By my signature on this Bid Form, I certify, under penalty of perjury under the laws of the State of California, that the foregoing questionnaire and statements of the Public Contract Code Sections 10285.1, 10162, AND 10232 are true and correct.

**SIGN AND DATE**

Signature: \_\_\_\_\_

Name (print): \_\_\_\_\_

Title: \_\_\_\_\_

Date: \_\_\_\_\_

## BID FORM 10

### REFERENCES AND PREVIOUS EXPERIENCE

#### A. ENTER PROJECT AND BIDDER INFORMATION

Contract Name Cerone Division Boiler & Propane Tank Replacement

Contract Number C19123

Bidder Name \_\_\_\_\_

#### B. PROJECT EXPERIENCE

##### IMPORTANT INFORMATION

Each Bidder must have the following minimum experience:

1. Within the past five years, Bidder must have completed at least one heating hot water boiler installation for a public agency or commercial owner located in the state of California, including related piping, pumps, and controls.
2. Within the past five years, Bidder must have completed at least one commercial dismantling and removal of an aboveground Liquefied Petroleum Gas storage tank system located in the state of California.
3. Within the past five years, Bidder must have completed at least one aboveground Liquefied Petroleum Gas storage tank (ASME Container, size in excess of 2,000 gallons [water capacity]) installation in the state of California, including related piping and equipment.

A Bidder can demonstrate this experience through either its subcontractor, key personnel, or the entity as a whole.

#### Does Bidder meet the experience requirements indicated ABOVE?

Yes     No (please check one)

**NOTE:** A "No" response will render the **Bid non-responsive**.

**CONTINUED ON NEXT PAGE →**

**BID FORM 10 (continued)**  
**REFERENCES AND PREVIOUS EXPERIENCE**

**C. ENTER REFERENCE INFORMATION**

Bidder shall completely fill in this form **three completed projects** of experiences detailed above. "Owner" refers to the public or private agency for which services were provided. Use additional sheets, if necessary.

**REFERENCE 1**

Owner Agency/Firm Name \_\_\_\_\_

Address \_\_\_\_\_ Phone Number \_\_\_\_\_

Contact Name for Owner \_\_\_\_\_ Email for Contact \_\_\_\_\_

Dollar Value of Project \$ \_\_\_\_\_ Date Started \_\_\_\_\_ Date Completed \_\_\_\_\_

Detailed Scope of Work \_\_\_\_\_

---

---

**REFERENCE 2**

Owner Agency/Firm Name \_\_\_\_\_

Address \_\_\_\_\_ Phone Number \_\_\_\_\_

Contact Name for Owner \_\_\_\_\_ Email for Contact \_\_\_\_\_

Dollar Value of Project \$ \_\_\_\_\_ Date Started \_\_\_\_\_ Date Completed \_\_\_\_\_

Detailed Scope of Work \_\_\_\_\_

---

---

**CONTINUED ON NEXT PAGE →**



**BID FORM 10 (continued)**  
**REFERENCES AND PREVIOUS EXPERIENCE**

**REFERENCE 1**

Owner Agency/Firm Name \_\_\_\_\_

Address \_\_\_\_\_ Phone Number \_\_\_\_\_

Contact Name for Owner \_\_\_\_\_ Email for Contact \_\_\_\_\_

Dollar Value of Project \$ \_\_\_\_\_ Date Started \_\_\_\_\_ Date Completed \_\_\_\_\_

Detailed Scope of Work \_\_\_\_\_

---

---

*[This Page Intentionally Left Blank]*

## SECTION 5 CONTRACT FORMS

It is not necessary to complete these Contract Forms to bid on this project. The Successful Bidder will be required to execute all the following Contract Forms if the Contract is awarded:

- |                        |  |
|------------------------|--|
| <b>Contract Form 1</b> | Construction Agreement<br><u>Note:</u> Form must be acknowledged by a notary |
| <b>Contract Form 2</b> | Performance Bond<br><u>Note:</u> Form must be acknowledged by a notary       |
| <b>Contract Form 3</b> | Payment Bond<br><u>Note:</u> Form must be acknowledged by a notary           |
| <b>Contract Form 4</b> | Listing of Subcontractors, Suppliers, and Subconsultants                     |
| <b>Contract Form 5</b> | Designation of Authorized Representative                                     |

These Contract Forms will be returned to:

Santa Clara Valley Transportation Authority  
Procurement, Contracts and Materials Management  
Attention:           Kiet Vu            
3331 North First Street, Building B  
San José, California 95134

*[This Page Intentionally Left Blank]*

## CONTRACT FORM 1 CONSTRUCTION AGREEMENT

This Construction Agreement (“Agreement”) is entered into between the Santa Clara Valley Transportation Authority (“VTA”) and

**INSERT SUCCESSFUL BIDDER’S COMPANY NAME**

(“Contractor”) as of the date set out below. VTA and Contractor agree as follows:

1. **Scope of Work.** Contractor shall perform the Work as described in

**Cerone Division Boiler & Propane Tank Replacement  
Contract C19123**

in a satisfactory and workmanlike manner and in accordance with the provisions of the Contract Documents.

2. **Compensation.** Full compensation to Contractor for the complete and satisfactory performance of the Work under the Contract and all provisions of the Contract Documents, and for Contractor's payment of all obligations incurred to others in performance of the Work, is the Total Contract Price (as defined in Contract **Section 2.5 Definitions**) of **\$ INSERT TOTAL CONTRACT PRICE**, as this amount may be adjusted in accordance with other provisions of the Contract. All costs for Work shown or indicated in the Contract Documents, even if not specifically provided for by a Bid item in the Schedule of Quantities and Prices shall be included in the Total Contract Price per Contract **Section 7.59 Progress Payments**.

3. **Contract Documents – Order of Precedence.** The following sections of the Contract Documents are incorporated by reference into this Construction Agreement:

Section 5.0	Contract Forms
Section 4.0	Bid Forms
Section 1.0 –3.0	Invitation for Bid, Foreword, and Instructions to Bidders including Appendices referenced therein except Appendix C
Section 6.0	Special Conditions, including Appendices referenced therein except Appendix C
Section 7.0	General Conditions including Appendices referenced therein except Appendix C
Appendix C	Business Diversity Policy and Requirements
Section 8.0	Technical Specifications
Section 9.0	Contract Drawings and Plans

These documents are essential parts of the Contract between the parties and are intended to be complementary and to describe and provide for the entirety of the Work. In the event of conflict among the documents, precedence shall be given in the order listed above. In the event of any discrepancy between any drawing and the dimensions written thereon, the dimensions shall be taken as correct. Detail drawings shall prevail over general drawings.

4. **Quality of Work.** Where the plans and specifications describe portions of the Work in general terms, but not in complete detail, it is understood that only the best general practice is to prevail and that only materials and workmanship of the first quality are to be provided.

5. **Time for Performance.** Contractor shall commence the Work immediately upon issuance by VTA of a Notice to Proceed and shall complete all of the Work by the dates specified in Contract **Section 6.4 Time for**

**Performance.** The issuance of a Notice to Proceed is contingent upon Contractor's submittal of proper insurance certificates, performance bond, payment bond, Listing of Subcontractors, Suppliers and Subconsultants, Federal and State Tax Forms, Erosion and Sediment Control Action Plan Element (ESCAPE), and executed Construction Agreement no later than **six (6) working days** following the date of VTA's Notice of Award. The first chargeable day under the Contract is set out in Contract **Section 6.4 Time for Performance**.

- 6. Entire Contract.** The Contract constitutes the entire agreement between VTA and Contractor respecting the subject matter hereof. All other agreements, understandings and communications between the parties hereto are deemed to be merged into and superseded by the provisions of the Contract. No modification or change to the Contract shall have any force or effect unless it is in writing and expressly referred to as being a change order to the Contract. If any provision of the Contract is held by a court of competent jurisdiction to be invalid, void or unenforceable, the remaining provisions will continue in full force without being impaired or invalidated in any way.
- 7. Responsible Conduct.** Contractor shall at all times deal in good faith and truthfully with VTA. Contractor shall submit documentation to VTA, including reports, claims, requests for change orders, equitable adjustment, Contract modifications or requests of any kind seeking increased compensation or decreases of an obligation on the Contract only in good faith and upon an honest evaluation of the underlying circumstances and an honest calculation of any amount being sought. A violation of this standard of conduct will subject Contractor to being deemed "non-responsible" pursuant to SCVTA Administrative Code, Chapter 9, Article III and potentially ineligible for future contracts with VTA, regardless of whether VTA relied on or responded to the submission.

**IN WITNESS WHEREOF** two identical counterparts of this instrument, each of which shall for all purposes be deemed an original thereof, have been duly executed by VTA and Contractor respectively, on the dates set out below.

**INSERT NAME OF CONTRACTOR**

**SANTA CLARA VALLEY TRANSPORTATION AUTHORITY**

By: \_\_\_\_\_

By: \_\_\_\_\_

Name: \_\_\_\_\_

John Wesley White  
Chief Procurement Officer

Title: \_\_\_\_\_

Date: \_\_\_\_\_

By: \_\_\_\_\_

Contractor's License No.: \_\_\_\_\_

Nuria I. Fernandez  
General Manager / CEO

Class: \_\_\_\_\_

Expiration Date: \_\_\_\_\_

Date: \_\_\_\_\_

**CONTRACT FORM 2  
PERFORMANCE BOND FOR PUBLIC WORKS**

KNOW ALL PEOPLE BY THESE PRESENTS: That

**WHEREAS**, the Santa Clara Valley Transportation Authority (“VTA”) has awarded to

**INSERT SUCCESSFUL BIDDER’S COMPANY NAME**

(“Principal”) a contract described as:

**Cerone Division Boiler & Propane Tank Replacement  
Contract C19123**

and all of the Contract Documents attached to or forming a part of said contract (herein collectively referred to as the “Contract”) are hereby referred to and made a part hereof; and

**WHEREAS**, said Principal is required under the terms of said Contract to furnish a bond executed by an admitted surety insurer for the faithful performance of said Contract;

**NOW THEREFORE**, we, the Principal and

**INSERT SURETY COMPANY**

as Surety, are held and firmly bound VTA in the penal sum of **\$ INSERT TOTAL CONTRACT PRICE**, in lawful money of the United States of America, for the payment of which sum well and truly to be made, we bind ourselves, our heirs, executors, administrators and successors, jointly and severally, firmly by these presents.

The condition of this obligation is such that if the above-bound Principal, its heirs, executors, administrators, successors or assigns, shall in all things stand to and abide by, and well and truly keep and perform the covenants, conditions and agreements in the said Contract and any alteration thereof made as therein provided, on their part, to be kept and performed at the time and in the manner therein specified, and in all respects according to their true intent and meaning, and shall indemnify, defend and save harmless VTA, its officers, agents, and employees, as therein stipulated, then this obligation shall become null and void; otherwise it shall be and remain in full force and effect.

And the said Surety for value received, hereby stipulates and agrees that no change, extension of time, alteration or addition to the terms of the Contract or to the Work to be performed thereunder or the specifications accompanying the same shall in any way affect its obligations on this bond, and it does hereby waive notice of any change, extension of time, alteration or additions to the terms of the Contract or to the Work or to the specifications.

In the event suit is brought upon this bond by VTA and judgment is recovered, Surety shall pay all costs incurred by VTA in such suit, including reasonable attorneys’ fees, court costs, expert witness fees and investigation expenses.

**IN WITNESS WHEREOF** this instrument, has been duly executed by Principal and Surety under their several seals on this \_\_\_\_\_ day of \_\_\_\_\_, 20\_\_\_\_, the names and corporate seals of the corporate parties being hereto affixed and those presents duly signed by their undersigned representatives, pursuant to authority of their governing bodies.

**PRINCIPAL**

**SURETY**

\_\_\_\_\_  
(Company)

\_\_\_\_\_  
(Company)

\_\_\_\_\_  
(Signature)

\_\_\_\_\_  
(Signature)

\_\_\_\_\_  
(Name – Please Print)

\_\_\_\_\_  
(Name – Please Print)

\_\_\_\_\_  
(Title)

\_\_\_\_\_  
(Title)

**CORPORATE SEAL**

**CORPORATE SEAL**

**NOTE:** Attach the following:

- 1) a copy of authorization for signatory for Principal, and
- 2) original or certified copy of unrevoked appointment, power of attorney, bylaws or other instrument entitling or authorizing person executing bond on behalf of surety to do so.



**CONTRACT FORM 3  
PAYMENT BOND FOR PUBLIC WORKS**

KNOW ALL PEOPLE BY THESE PRESENTS: That

**WHEREAS**, the Santa Clara Valley Transportation Authority (“VTA”) has awarded to

**INSERT SUCCESSFUL BIDDER’S COMPANY NAME**

(“Principal”) a Construction Agreement (“Contract”) for the furnishing of all materials, labor, services and transportation necessary, convenient and proper to the performance of

**Cerone Division Boiler & Propane Tank Replacement  
Contract C19123**, and

WHEREAS, said Principal is required by the California Civil Code Section 9550 to furnish a bond executed by an admitted surety insurer in connection with said Contract;

NOW THEREFORE, we, the Principal and

**INSERT SURETY COMPANY**

as Surety, are held and firmly bound unto VTA, in the penal sum of **\$ INSERT TOTAL CONTRACT PRICE**, in lawful money of the United States of America for the payment of which sum well and truly to be made, we bind ourselves, our heirs, executors, administrators, successors and assigns, jointly and severally, firmly by these presents.

The condition of this obligation is such that if said Principal, its subcontractors, heirs, executors, administrators, successors, or assigns, shall fail to pay any of the persons named in Section 9100 of the California Civil Code, or amounts due under the Unemployment Insurance Code with respect to work or labor performed under this Contract by any such claimant, the Surety will pay for the same, in an amount not exceeding the sum hereinabove specified, and also, in case suit is brought upon this bond, a reasonable attorney's fee to be fixed by the court.

This bond shall inure to the benefit of any of the persons named in Section 9100 of the California Civil Code, so as to give a right of action to such persons or their assigns in any suit brought upon this bond.

It is further stipulated and agreed that the Surety on this bond shall not be exonerated or released from the obligation of this bond by any change, extension of time for performance, addition, alteration or modification in, to, or any contract, plans, specifications, or agreement pertaining or relating to any scheme or work of improvement hereinabove described or pertaining to or relating to the furnishing of labor, materials, or equipment therefor, nor by any change or modification of any terms of payment or extension of the time for any payment pertaining or relating to any scheme or work of improvement hereinabove described, nor by any rescission or attempted rescission of any such Contract or agreement or the bond, nor by any conditions precedent or subsequent in the bond attempting to limit the right of recovery of claimants otherwise entitled to recover under any such contract or agreement or under the

bond, nor by any fraud practiced by any person other than the claimant seeking to recover on the bond and that this bond be construed most strongly against the Surety and in favor of all persons for whose benefit such bond is given, and under no circumstances shall Surety be released from liability to those for whose benefit such bond has been given, by reason of any breach of contract between VTA and original Contractor or on the part of any obligee named in such bond, but the sole conditions of recovery shall be that claimant is a person described in Section 8400 or 8402 of the California Civil Code, and has not been paid the full amount of its claim and that Surety does hereby waive notice of any such change, extension of time, addition, alteration or modification herein mentioned.

If VTA brings suit upon this bond and judgment is recovered, the Surety shall pay all litigation expenses incurred by VTA in such suit, including reasonable attorneys' fees, court costs, expert witness fees and investigation expenses.

**IN WITNESS WHEREOF** this instrument has been duly executed by Principal and Surety under their several seals on this \_\_\_\_\_ day of \_\_\_\_\_, 20\_\_\_\_, the names and corporate seals of the corporate parties being hereto affixed and those presents duly signed by their undersigned representatives, pursuant to authority of their governing bodies.

**PRINCIPAL**

**SURETY**

\_\_\_\_\_  
(Company)

\_\_\_\_\_  
(Company)

\_\_\_\_\_  
(Signature)

\_\_\_\_\_  
(Signature)

\_\_\_\_\_  
(Name – Please Print)

\_\_\_\_\_  
(Name – Please Print)

\_\_\_\_\_  
(Title)

\_\_\_\_\_  
(Title)

**CORPORATE SEAL**

**CORPORATE SEAL**

**NOTE:** Attach the following:

- 1) a copy of authorization for signatory for Principal, and
- 2) original or certified copy of unrevoked appointment, power of attorney, bylaws or other instrument entitling or authorizing person executing bond on behalf of surety to do so.

**CONTRACT FORM 4**  
**LISTING OF SUBCONTRACTORS, SUPPLIERS, AND SUBCONSULTANTS**

Contractor shall complete the form below for each subcontract for all subcontractors of all tiers, suppliers of materials, and subconsultants. Include all firms.

**IMPORTANT INFORMATION**

- The form is to be completed and submitted with the other Contract Forms
- All subcontractors are to be listed on this form and must be registered with the California Department of Industrial Relations (“DIR”) as further set forth at Section 7.8, Labor Provisions.

**C. ENTER PROJECT AND CONTRACTOR INFORMATION**

**Contractor Name:** \_\_\_\_\_

**Total Contract Price:** \$ \_\_\_\_\_

**Amount to be subcontracted:** \$ \_\_\_\_\_

**Percentage to be subcontracted:** \_\_\_\_\_ %

**D. ENTER NAMES OF SUBCONTRACTORS, SUPPLIERS, AND SUBCONSULTANTS**

Name of Subcontractor, Supplier, Subconsultant	City and State	Bid Item or Portion of Work	Ethnicity (see code Below)	Email Address	DIR Registration Number	Estimated Dollar Amount of Subcontract

**NOTES:**

1. For Ethnicity, enter one of the following codes: A=Asian, SA=Subcontinent Asian, B=Black, C=Caucasian, H=Hispanic, NA=Native American, O=Other.
2. DIR Registration is for SUBCONTRACTOR ONLY subcontractor only.
3. Copy and add additional pages if necessary

*[This Page Intentionally Left Blank]*

**CONTRACT FORM 5**  
**DESIGNATION OF AUTHORIZED REPRESENTATIVE**

In accordance with Sections 7.24, Authorized Representatives and 7.25, Notices and Communications, Contractor hereby designates as its Authorized Representative the person listed below. Contractor's Authorized Representative shall have full authority to act on Contractor's behalf in all matters within the scope of this Contract.

**Name of Authorized Representative:** \_\_\_\_\_

**Business Address:** \_\_\_\_\_

**Business Phone:** \_\_\_\_\_

**Business Email:** \_\_\_\_\_

**24-Hour Emergency  
Phone:** \_\_\_\_\_

**Designated Alternate:** \_\_\_\_\_

**Alternate's 24-Hour Emergency  
Phone:** \_\_\_\_\_

The person signing this Designation of Authorized Representative for the Bidder certifies that he or she is authorized by the Bidder to do so and that the Bidder shall be bound contractually by that signature.

Signature: \_\_\_\_\_

Name (print): \_\_\_\_\_

Title: \_\_\_\_\_

Date: \_\_\_\_\_

*[This Page Intentionally Left Blank]*

## **SECTION 6 SPECIAL CONDITIONS**

### **6.1. Indemnity and Defense of Claims**

#### **6.1.1. Indemnify and Hold Harmless**

Contractor must indemnify and hold harmless VTA, any public agencies within whose jurisdiction, on whose behalf, or on whose property the Work is being performed, any party VTA is contractually obligated to identify in this Contract as an indemnitee, and each of their respective Board(s) of Directors, Board(s) of Supervisors, Councils, individual board members, officers, agents, employees, and consultants (each, an "Indemnitee"; collectively, the "Indemnitees") from any claims, liabilities, losses, injuries, damages, expenses, fines, penalties, liens, stop notices, or fees and costs (including attorneys' and experts' fees and costs) arising out of, pertaining to, or caused by, or in any way relating to the Work, including the performance of this Contract or any subcontract hereunder, by Contractor and/or its agents, employees, or subcontractors, whether such claims, liabilities, losses, injuries, damages, expenses, fines, penalties, liens, stop notices, or fees and costs (including attorneys' and experts' fees and costs) are based upon a contract, or for personal injury, death or property damage or upon any other legal or equitable theory whatsoever.

#### **6.1.2. Limitation on Indemnity**

Notwithstanding any language in this Contract to the contrary, Contractor is not obliged to indemnify and/or hold harmless the Indemnitees from any claims, liabilities, losses, injuries, damages, expenses, fines, penalties, liens, stop notices, or fees and costs (including attorneys' and experts' fees and costs) arising from the sole or active negligence or willful misconduct of VTA or its agents, servants or independent contractors who are directly responsible to VTA, or from damages for defects in designs furnished by those persons.

#### **6.1.3. Duty to Defend**

Contractor agrees, at its own expense, and upon written request by VTA or any individual Indemnitee, to immediately defend any suit, action, claim, or demand brought against any Indemnitee founded upon, alleging, or implicating any claims, liabilities, losses, injuries, damages, expenses, fines, penalties, liens, stop notices, or fees and costs (including attorneys' and experts' fees and costs) covered by Contractor's indemnity obligation set forth in this **Section 6.1.1**, and regardless of whether Contractor and/or any of its agents, employees, or subcontractors, was, in fact, liable. In the event a court of competent jurisdiction determines that any suit, action, claim, or demand brought against any Indemnitee was caused by the sole or active negligence or willful misconduct by VTA or its agents, servants or independent contractors who are directly responsible to VTA, VTA will promptly reimburse Contractor for costs of defending the Indemnitees in such action incurred by Contractor, but only in proportion to the sole or active negligence or willful misconduct of VTA or its agents, servants or independent contractors who are directly responsible to VTA.

#### **6.1.4. Survive Expiration or Termination**

The indemnity and defense of claims terms set forth in this Section 6.1 will survive the expiration or termination of the Contract and remain in full force and effect.

## 6.2. Insurance

Contractor's attention is directed to **Appendix A Insurance Requirements** of this Contract.

It is highly recommended that proposers confer with their insurance carriers or brokers in advance of bid submission to determine the availability of insurance certificates and endorsements prescribed in **Appendix A Insurance Requirements**.

## 6.3. Contract Bonds and Surety Requirements

Prior to execution of the Contract, Successful Bidder must file with VTA on the forms provided herein, surety bonds in the amounts and for the purposes noted below, duly executed by an admitted surety insurer satisfactory to VTA; *provided, however*, that no bonds are required on Bids of \$25,000 or less. Successful Bidder must pay all premiums and costs relating to required bonds, whether direct or incidental thereto. Each bond must be signed by both Successful Bidder and surety.

### 6.3.1. Payment Bond

The Payment Bond must be in an amount of **100%** of the Total Contract Price and shall inure to the benefit of persons performing labor or furnishing materials in connection with the Work. This bond must be maintained in full force and effect until all Work under the Contract is completed and accepted by VTA, and until all claims for materials and labor have been paid. See the form of the Payment Bond in Section 5 Contract Forms.

### 6.3.2. Performance Bond

The Performance Bond must be in an amount of **100%** of the Total Contract Price and shall insure the faithful performance by Contractor of all of the Work. It must also insure the replacement of, or making acceptable, any defective materials or faulty workmanship. See the form of the Performance Bond in Section 5 Contract Forms.

### 6.3.3. Surety Requirements

Sureties for necessary bonds must:

- Be an admitted surety insurer.
- Have an AM Best's rating of no less than A VII.
- Comply with the provisions of Code of Civil Procedure Section 995.660.
- If Federal requirements apply (refer to **Section 1.8**), be a current Treasury Listed Surety (Federal Register).

Should any surety or sureties be deemed unsatisfactory at any time by VTA, notice will be given to Contractor to that effect, and Contractor shall forthwith substitute a new surety or sureties satisfactory to VTA; *provided, however*, that the time set out in the Notice of Award for submitting bonds will not be extended thereby. No further payment will be due or will be made under the Contract until the new sureties qualify and are accepted by VTA.

All alterations, time extensions, extra and additional Work, and other changes authorized by the specifications, or any part of the Contract, may be made without securing consent of the surety or sureties on the Contract bonds.



#### **6.4. Time for Performance**

The time limit for completion of all Work is **354 calendar days** commencing on the First Charged Day. First Charged Day is defined as the 20th day following the issuance of a NOA by VTA. Should the First Charged Day fall on a Friday or weekend or holiday, the following working day shall be the First Charged Day.

#### **6.5. Liquidated Damages**

Contractor agrees that its failure to complete the Work or any part thereof within the time periods or by the dates specified in the Contract, as such time periods or dates may be revised by change order, will result in damages being sustained by VTA. Since it is impractical and infeasible to determine the actual amount of such damage, it is further agreed that Contractor will pay to VTA, as agreed, fixed and liquidated damages and not as a penalty, the amount specified hereunder for each day of delay or part thereof until such Work or part thereof is completed and accepted, and Contractor and its surety will be liable for the amount thereof.

VTA may deduct the sum of liquidated damages from progress or final payment(s) due under this Contract.

The Work must be completed and accepted within the duration set out in **Section 6.4 Time for Performance**. Liquidated Damages will be assessed at \$625 per calendar day thereafter for each and every day beyond the time specified in **Section 6.4**.

#### **6.6. Contract Data Requirements**

##### **6.6.1. Contract Data Requirements**

Contractor must submit to VTA the items shown in **Table B-1 Contract Data List** ("Contract Data List") and **Table B-2 Technical Submittals List** ("Technical Submittals List") of **Appendix B Contract Data Requirements**. The Contract Data List and Technical Submittals List is intended to summarize the requirements for submittals as specified in the Contract Documents. If conflicts exist between the lists in **Appendix B** and the referenced paragraph, the referenced paragraph will take precedence. Omission of items required elsewhere in the Contract from the Technical Submittals List, will not relieve Contractor of the responsibility to submit the required documentation as stipulated by the related Contract section.

VTA may withhold amounts from any payments otherwise due as it determines necessary for Contractor's failure to provide submittals as required. This amount may be up to 10% of the payment or \$10,000.00, whichever is greater for each item. Failure of Contractor to submit any item within 30 days of its due date may result in forfeiture of any or all of the withholding per **Section 7.59.6 Special Withholding**.

##### **6.6.2. Submittal**

Contractor must submit to VTA the items shown on the Contract Data List and the Technical Submittals List in compliance with the times and the number of copies specified therein. Requirements and procedures for preparing and transmitting submittals must conform to the provisions of **Section 7.43 Submittal of Shop Drawings, Product Data and Samples** and this **Section 6.6**.

All submittals must be accompanied by a **Submittal Cover Letter** provided by VTA. Contractor must:

- a. Submit drawings, schedules and samples as required in the Technical Submittals List.
- b. Coordinate preparation and processing of submittals with performance of construction activities;

- c. Coordinate each submittal with fabrication, purchasing, testing, delivery, other submittals, and related activities that require sequential activity; and
- d. Coordinate transmittal of different submittals for related parts of the Work so that processing will not be delayed because of the need to review submittals concurrently for coordination.
- e. Submit any supporting data, such as manufacturer's literature and/or calculations, in the same manner and number as the drawings, schedules and samples required.

Given **Section 6.4 Time for Performance**, Contractor must allow adequate time for an Initial Review or Concurrent Review (as defined below), whichever is applicable, including time for resubmittals.

- a. Initial Review: Contractor must allow twenty (20) working days for initial review and appropriate action by VTA on each submittal. Contractor must allow additional time if processing must be delayed to permit coordination with subsequent submittals. VTA will advise Contractor when a submittal being processed must be delayed for coordination.
- b. Concurrent Review: Where concurrent review of submittals by VTA and other parties is required, Contractor must allow thirty (30) working days for initial review and appropriate action by VTA of each submittal.

The time period for review (whether Initial Review or Concurrent Review) will commence on the day of VTA's receipt of submittal. If the submittal is received by VTA after 3PM, time period for review will commence on the following working day.

VTA's acceptance of submittals will be general and will not be construed as (i) permitting any deviation from Contract requirements, (ii) offering relief of responsibility for any errors or omissions, or (iii) approving any deviation from details furnished by VTA except as provided otherwise in **Section 8 Technical Specifications**. If submittals show variations from Contract requirements for any reason, such variations must be described in the submittal cover letter.

If variations result in an adjustment to the Contract price or time for performance, the adjustment will be subject to approval by VTA. Failure to describe variations will not relieve Contractor from the responsibility of executing the Work according to the terms of the Contract, even though such submittals have been accepted by VTA.

Contractor must submit documents such as certificates, reports and test results not shown in the Technical Submittals List, but specified in **Section 8 Technical Specifications**. Three (3) copies of each item are required unless specified otherwise. Notice of completion of work to hold points specified in the encroachment permit must be provided ten (10) working days before estimated completion of that portion of the Work.

If VTA determines that substantial corrections are required, each submitted item will be marked AMEND AND RESUBMIT (A/R). The required corrections will be explained. In these instances, VTA will not be deemed to have accepted the submittal and it must be corrected and resubmitted. One copy will be returned for correction.

Resubmittals will be handled in the same manner as the initial submittal, and Initial Review and Concurrent Review period, whichever is applicable, will begin again. Contractor must direct specific attention to revisions other than those requested by VTA on previous submittals either by an accompanying letter or on the resubmitted drawings.

If accepted by VTA each submittal will be stamped NO EXCEPTIONS TAKEN (NET) and dated indicating acceptance.

Work included in submittals marked as MAKE CORRECTIONS NOTED (MCN) may be carried out provided that VTA's request has been properly addressed and resolved, and Contractor complies with all required corrections or modifications. Contractor must make corrections to the resubmittals and resubmit to VTA within 5 working days. Working and shop drawings will be redlined by VTA and the Work will be carried out only using submittals that (i) are stamped either MAKE CORRECTIONS NOTED (MCN) or NO EXCEPTIONS TAKEN (NET), and (ii) which bear VTA's signature. No changes may be made thereon except by written direction from VTA.

Contractor is responsible for and will bear all cost of damages that may result from ordering material or from proceeding with Work before VTA acceptance.

Contractor must submit six (6) legible copies of complete and detailed working and shop drawings as required for the performance of the Work, which must be suitable for electronic scanning. In addition, drawings must be prepared on a reproducible sheet measuring 22 inches by 34 inches unless approved otherwise. Each full size drawing sheet must have a blank area five inches by five inches minimum, located above the title block, for VTA's acceptance stamp. The title block must display the following:

- Contract Number and Name
- Number and Title of Drawing
- Date of Drawing or Revision
- Name of Firm originating Drawing
- Clear identification of contents
- Location of work
- Referenced Technical Specifications

Also, Contractor must furnish detail drawings for any temporary work and the method of proposed construction for the safe and successful completion of such Work.

All submittals for electrical equipment must conform to the provisions of the appropriate technical specifications of the Contract. All electrical materials must be tagged in conformance with the provisions of **Section 7.49 Certificates of Compliance and Testing**, before delivery to the Worksite. VTA will reject untagged electrical materials.

Contractor must furnish samples as specified and requested by VTA as soon as possible after the request. Unless indicated otherwise, no less than two (2) identical samples of each type required must be submitted. Shipping charges must be prepaid by Contractor. Products for which samples are requested must not be used until accepted in writing by VTA. Each sample must be labeled to indicate:

- Name of Project
- Contract Number
- Name of Contractor
- Name of subcontractor or supplier, if applicable
- Material or equipment represented
- Source
- Name of producer and brand, if any
- References to applicable plans and specifications
- Location of the Work

Contractor will test samples as specified. Accepted samples not destroyed in testing may be retained by VTA. Samples not approved by VTA will be returned at Contractor's expense, if so requested at the time of submittal. Contractor will mail a letter under separate cover submitting each shipment of samples detailing the information required in the preceding paragraph. Contractor must enclose a copy of the letter with the shipment.

### **6.7. Permits, Fees and Inspections**

Contractor must obtain all necessary permits from all governing agencies with jurisdiction over the Work and make arrangements for inspections and approvals for the Work. Contractor must prepare and submit all jurisdictional forms to VTA, including those requiring VTA signature. Anticipated forms and permits are listed in Appendix N – Permit Applications. Contractor must submit applicable forms and documentation to VTA within two weeks of VTA approval of related product submittal, or within two weeks of written request by VTA for related information, whichever comes first. Contractor must pay for all jurisdictional charges related to securing the permits, approvals, and completing the required paperwork described in Appendix N, including plan check, inspection, permit application, and other fees related to securing the jurisdictional approval. Contractor to include the cost of all required jurisdictional charges in the Bid price.

VTA will review and submit permit applications and documentation to the jurisdictional authorities. Contractor to provide VTA with a form of fee payment accepted by the authority or make fee payments directly to the jurisdictional authority on VTA's behalf.

Identified Governing Agencies: VTA has identified the agencies listed below as having jurisdiction over the Work. The list is not necessarily complete, and Contractor is not relieved from the obligation of identifying all agencies having jurisdiction over the Work and complying with all applicable requirements of those agencies.

The identified agencies include:

- Bay Area Air Quality Management District (BAAQMD)
- Santa Clara County Department of Environmental Health; Hazardous Materials Compliance Division (HMCD). HMCD is the Certified Unified Program Agency (CUPA) for this Project.
- California Department of Industrial Relations – Division of Occupational Safety & Health (DOSH) – Pressure Vessel Unit

No building permit is required. VTA is the authority having jurisdiction for Building Code compliance over its Cerone Division facility.

Contractor must comply with all requirements set forth by the identified agencies in preparation for testing and commissioning of the propane system and vaporizers. Contractor must notify VTA two weeks in advance of tests and inspection points to be witnessed by authorities having jurisdiction.

Final payment to Contractor will not be made until the terms and conditions of all permits have been satisfied..

### **6.8. Payment of Fines and Fees**

Contractor will be responsible for the payment of all fines levied against VTA arising from or related to activities over which Contractor has responsibility under Contract Documents, or for Work which does not conform to the Contract Documents.

## **6.9. VTA Furnished Materials**

Any materials to be furnished by VTA will be at locations designated herein or they will be delivered to the Worksite. Such VTA furnished materials must be hauled to and properly stored at the place of use by Contractor at Contractor's expense including all necessary loading and unloading that may be involved. All costs of storing, handling, and installing VTA-furnished material will be considered as included in the Contract price paid for the Bid item involving VTA-furnished material.

Contractor will be held responsible for all materials furnished to Contractor, and must pay all demurrage and storage charges. If any VTA-furnished materials are lost or damaged from any cause whatsoever after receipt by Contractor, Contractor will be liable to VTA for the cost of replacing or repairing such VTA furnished material and the cost thereof may be deducted from any monies due or to become due Contractor.

In addition, VTA will furnish to Contractor, upon request, a maximum of ten (10) sets of conformed contract documents or bid documents including all addenda if conformed documents are not available. Contractor will be responsible for making available to its subcontractors and suppliers all documents required to complete their Work. Upon Contractor's request, VTA will provide electronic copies of the conformed Contract Documents.

## **6.10. Delivery, Unloading and Storage**

Contractor is completely responsible for all delivery, unloading and storage activities required for the completion of Work.

## **6.11. Work Sequence and Constraints**

The Work will be performed on an active facility with ongoing 24-hours/day bus operations and maintenance activities. All Contract activities are subordinate to the ongoing function of these facilities. It is Contractor's responsibility to coordinate, phase, schedule and perform its Work without disruption to these activities. Storage of materials and equipment under Contractor's control must be in a manner that does not interfere with VTA operations.

Contractor must cooperate with, and coordinate its Work with, any other contractor or vendor that may be performing work in the immediate area of the Worksite.

### **6.11.1. Construction Hours**

The site will be accessible to Contractor as directed by VTA. In general, Contractor's construction activity may occur between the hours of 7:00 AM and 4:00 PM, Monday through Friday. Work activities may be permitted outside of normal hours with prior written VTA approval. Certain Work activities may be required to be performed outside of normal hours.

### **6.11.2. Building Access**

Contractor will be granted permission to enter the following buildings at VTA's Cerone Division as described below. Roof access is considered the same as building access. Certain Work activities may require access at times other than the normal project hours. Contractor must receive written permission from VTA in advance for access to buildings not listed below, or for access outside of normal project hours (whether required by Contract, or for Contractor convenience). All means of access, and access routes, will be as directed by VTA. VTA bus operations will be ongoing and Contractor must plan Work around VTA operations. Contractor must plan Work to minimize disruption to VTA Employees.

For each building to be accessed, Contractor must submit a Building Access Work Plan (BAWP). BAWP must be submitted to VTA for review and approval at least VTA three (3) weeks in advance of desired access date. BAWP must describe:

- 1) Sequence of Work Activities, with associated durations. A day by day breakdown must be included.
- 2) Equipment (ladders, lifts, scaffolding, etc.) and machinery requested to be used inside buildings
  - a) Tools and materials to be used which generate dust, fumes, sparks (or can serve as a source of ignition), or that can be expected to generate significant noise under typical operation. Significant noise will be defined as greater than 70 dBA.
- 3) Steps to be taken to minimize disruption to VTA operations and staff
- 4) Protective measures to be taken for safety of VTA and Contractor staff

For buildings with multiple phases (or areas or Work), BAWP must address different phases of work (or different areas of work) separately, otherwise multiple BAWP's must be submitted for each phase (or area) of work.

**Building B** - Normal Contractor access hours: 8:00 AM to 4:00 PM, Monday through Friday.

**Building E** - Normal Contractor access hours: 7:00 AM to 4:00 PM, Monday through Friday.

**Building F** - Normal Contractor access hours: 7:00 AM to 4:00 PM, Monday through Friday.

In the following rooms of Building F, Contractor's access is further restricted as follows:

- 1) Employee exercise room:
  - a) Contractor must close the employee exercise room to access from VTA staff whenever Contractor needs to perform work in the room.
  - b) Contractor must provide VTA notice of intent to close the employee exercise room, at least two (2) business days in advance.
- 2) Secured Storage Area:
  - a) Access to the secured storage area in the north-east corner of Building F must be requested at least fourteen (14) days in advance.

**Building G** - Normal Contractor access hours:

- Mechanical Room - 7:00 AM to 4:00 PM, Monday through Friday.
- Parts Warehouse (exterior & interior portions), and central corridor hallway - 7:00 AM to 3:00 PM, Monday through Friday.
- Shops, offices, bus bays, and other remaining areas - 7:00 AM to 1:00 PM, Monday through Friday.

### **6.11.3. Preservation of Services**

Preserve existing facilities, systems, or services in full operating condition until approved otherwise in writing by VTA. Request in writing, a minimum of 14 days in advance, permission to:

- Shut down, interrupt, or impair existing VTA utility services or systems;
- Conduct activities that impair or restrict vehicular access within and around the bus yard; and
- Conduct activities that may shutdown, interrupt, or impair the ongoing operations and activities at VTA's Cerone Division.

#### **6.11.4. Preservation of Diesel & LPG Refueling Access**

VTA receives daily shipments of diesel fuel, critical to VTA operations. Diesel fuel is delivered to and unloaded at the existing diesel fill port located in the drive aisle between Building G and Building F (location indicated on the Contract Drawings). Contractor is required to conduct Work along the northern portion of this drive aisle. Contractor must always maintain at least half of the drive aisle accessible for the diesel refueling operation. The diesel refueling process takes approximately 45 to 60 minutes. Contractor must stand down all construction equipment and use only hand tools in the drive aisle during the diesel refueling process. No smoking, hot work, or other activities capable of generating a spark (or source of ignition) will be permitted within 50' of the diesel fill port or any part of the refueling vehicle, until the conclusion of the refueling operation and the departure of the diesel refueling vehicle.

VTA receives monthly shipments of LPG fuel, critical to VTA operations. LPG fuel is delivered to and unloaded at the existing LPG fill port (location indicated on the Contract Drawings). Contractor must provide access to the existing LPG fill port when requested by VTA to facilitate refueling operations. During any LPG refueling operation (for the entirety of the operation), Contractor must stand down all construction activities within 50' of the existing LPG and propane gas storage and delivery system, including but not limited to:

- The LPG fill port & tank;
- Any part of the refueling vehicle;
- The Propane Vaporizers; and
- Any propane gas pressure regulators

until the conclusion of the refueling operation and the departure of the LPG refueling vehicle.

#### **6.11.5. Utility Trenching Requirements**

Contractor must sequence utility trench Work to facilitate vehicular and pedestrian access through the work areas. All utility trenches must be appropriately covered over daily. Only trench sections actively under construction may be uncovered daily.

Trench sections in vehicular areas must be plated to withstand bus loading, and must be properly secured to prevent plates from slipping under acceleration or deceleration of buses traversing them.

Trench sections in pedestrian areas must be covered over with plywood, and the entire trench (and any related trip hazards) must be protected from pedestrians by caution tape and reflectorized delineators. Delineators must be spaced every ten feet or less.

**Safety Requirements – refer to and coordinate with Section 6.14, conform to NIOSH publication 98-126 Occupational Noise Exposure.**

#### **6.11.6. Coordination with VTA Contract C19010**

VTA Contract C19010 - "Cerone Division Emergency Generator Replacement" project will be conducting work within the vicinity of Contract C19123. See Appendix P – C19010 Reference Drawings for site plans depicting the area of work for contract C19010.

At the time of contract C19123's advertisement, the contract C19010 construction schedule forecasts that the majority of C19010 construction activity will be completed prior to C19123 mobilizing for field activities. C19010 construction activity may, however, continue through late 2020. It is not anticipated that C19123 will be impacted by C19010 construction activity, however C19123 must provide reasonable access for C19010.

#### **6.11.7. Preservation of Service to Existing Equipment**

The existing propane and Heating Hot Water (HHW) systems are critical to VTA operations. Contractor must preserve operation of the existing systems until the replacement systems are tested to be fully operational and approved by VTA to be placed into service. Contractor will not be responsible to maintain the function and operation of the existing systems. However, Contractor must provide access for VTA's vendor(s) to maintain the systems, on an as needed basis. Contractor must immediately repair (or modify) to the satisfaction of VTA any portion of any existing system that is damaged or rendered impaired by Contractor's operations or forces. Contractor must preserve the existing systems in operation until given permission by VTA in writing to decommission the system, or selective portions thereof.

The existing propane tank provides fuel via the existing vaporizers to propane fired emergency backup power generators at the Cerone Division. These emergency backup power generators are critical for operation of the bus facility, and must remain operational at all times. Contractor must preserve sufficient portions of the existing propane system in operation to keep the propane fired generators online at all times, until Contractor has been notified in writing by VTA that the propane generators have been decommissioned. The propane fired generators are being replaced by the concurrent C19010 contract. Contractor must phase the demolition work such adequate propane supply is preserved to the propane generators until they have been decommissioned.

#### **6.11.8. Utility Shutdowns, Interruptions, and Cut-overs**

Contractor must provide VTA at least three (3) weeks' notice of the requirement for any shutdown or interruption of any utility service or system (propane, electrical, HHW, communications, etc.), unless a greater time period is specified in the Technical Specifications.

Contractor must provide a cutover work plan for VTA approval, that among other items of concern, details interconnection points between new construction and existing systems and details the contractor's proactive approach to preventing adverse effects on existing equipment and systems. Cutover work plan must be submitted for VTA review at least four (4) weeks in advance of desired cutover date. Exact date of Propane and HHW piping cutover must be scheduled at least fourteen (14) days in advance.

Contractor may not smoke on project site, except at existing designated smoking locations established by VTA.

#### **6.12. Reserved**

#### **6.13. Sound Control Requirements**

Contractor must comply with all local sound control and noise level rules, regulations and ordinances that apply to any of the Work. If no maximum noise levels exist in local jurisdictions, the noise level from Contractor's operations, between the hours of 9:00 PM and 6:00 AM, must not exceed 86 dbA at a distance of fifty (50) feet from the Work activity. Each internal combustion engine, used for any purpose on the job or related to the job, must be equipped with a muffler of a type recommended by the manufacturer. No internal combustion engine may be operated on the project without said muffler. Noise level requirements shall apply to all equipment on the job or related to the job, including but not limited to trucks, transit mixers or transit equipment that may or may not be owned by Contractor. The use of loud sound signals shall be avoided in favor of light warnings except those required by safety laws for the protection of personnel.



## 6.14. Safety Precautions, Programs and First Aid Requirements

Contractor must promptly and fully comply with, carry out, and will, without separate charge to VTA, enforce compliance with the safety and first aid requirements stated herein, prescribed by applicable laws and regulations and those prescribed by an official or representative charged with the enforcement thereof. Contractor will take such other measures as may be necessary to the end that Work will be done in a safe manner and that the safety and health of employees and the people of local communities are safeguarded. Compliance with the provisions of this Special Condition by subcontractors will be the responsibility of Contractor.

### 6.14.1. Safety Supervision

Contractor must be responsible for initiating, maintaining and supervising all safety precautions and programs in connection with the Work. Contractor must:

- (1) Identify a competent individual, i.e.: a superintendent or foreman, who will be assigned to work at the Worksite and will be responsible for Worksite safety,
- (2) Develop and submit for review a **Site-Specific Safety Plan (SSSP)**, which addresses the scope of work to be performed and certifies that the **Designated Safety Representative** has received competent person training in all aspects of the Site-Specific Work Plan (SSWP), as described below, and
- (3) Develop and submit to VTA for review an **SSWP**, which will (i) describe each of the activities or tasks to perform a work operation. The SSWP will include staffing, materials, and equipment that will be used to complete the Work.

The SSWP will include a detailed description of the safety measures to be taken for the protection of personnel and equipment. Such items as protective gear, sign placement, specialized safety equipment, ventilation equipment, in-house safety programs, and additional safety supervision, if appropriate, will be identified.

The SSWP will be submitted by Contractor to VTA at least fourteen (14) days prior to the date and time of the proposed start of Work. No Work may begin until the SSWP has been reviewed by VTA and returned as either NET or MCN, as those terms are defined in Section 6.6.2. VTA may request additional explanation, request changes, or require Contractor to revise and resubmit the SSWP. If the SSWP is not acceptable to VTA, Contractor must revise and resubmit the SSWP and obtain an evaluation of NET or MCN before proceeding with the Work. A general SSWP must be prepared that covers all of the Contract Work including all construction operations and equipment. The SSWP must be coordinated with and submitted for review and approval at the same time as the Baseline schedule.

- (4) Comply with all state, federal, and local regulations with regards to safety. Contractor will provide a copy of its **Industrial Injury Prevention Program** to VTA.

Contractor's **Designated Safety Representative** will set up, carry forward and aggressively and effectively maintain the aforementioned safety program covering all phases of the Work. Contractor must take all precautions and follow all procedures for the safety of, and must provide all protection to prevent injury to, all persons involved in any way in the Work and all other persons, including, without limitation, the

employees, agents, guests, visitors, invitees and licensees of VTA who may be involved. This requirement applies continuously and is not limited to normal working hours.

#### **6.14.2. Hazardous Substances**

If Contractor encounters Worksite material reasonably believed to be asbestos, polychlorinated biphenyl (PCB) or other Hazardous Substance (as defined below) that has not been rendered harmless, Contractor must immediately stop Work in that affected area and report the condition through VTA's current Hazard Management Program (HMP). That portion of the Work in the affected area must not thereafter be resumed except by written agreement of VTA and Contractor if in fact the material is asbestos or PCB or other Hazardous Substance and has not been rendered harmless. That portion of the Work in the affected area must be resumed in the absence of asbestos or PCB or other Hazardous Substance, or when it has been rendered harmless, by written agreement of VTA and Contractor, or in accordance with a final determination by an environmental consultant employed or retained by VTA.

Contractor will not be required pursuant to **Section 7.9 Hazardous Materials or Unusual Conditions** to perform without consent, any portion of the Work relating to asbestos, PCB or other Hazardous Substances.

For purposes of the Contract Documents, "Hazardous Substance" has the meaning set forth in California Health and Safety Code, Chapter 6.6, (and all regulations enacted pursuant thereto) and also includes (to the extent not set forth in the Health and Safety Code) any additional substance or material that has been determined or during the time of performance of the Work is determined to be capable of posing a risk of injury to health, safety, property or the environment by any federal, state or local governmental authority.

#### **6.14.3. Safety Data Sheets and Hazardous Substances**

Contractor and subcontractors of each tier must provide VTA with Safety Data Sheets (SDS) for all materials to be incorporated into or used in the prosecution of the Work, including commonly used construction materials that contain any Hazardous Substance or mixture, including, without limitation any chemical listed by the State of California as a chemical known to cause cancer or reproductive harm (as defined in California Health and Safety Code, Chapter 6.6, and all regulations pursuant thereto). The Safety Data Sheets must contain all necessary and legally required information concerning such substances as asphalts, solvents, adhesives, epoxy resins, roofing sealant and bonding agents, mixtures or chemicals, in a format agreed to by VTA or as required by law. Contractor must maintain an electronic file or repository with the SDS's for all applicable materials currently on site. The electronic file must be updated as (or before) materials arrive on site, and must be accessible to VTA staff at all times. Contractor must submit access to the electronic file (with actual SDS for planned materials, or with sample SDS's for illustrative purposes) within 20 days following notice of award. Contractor must make provisions as requested by VTA, so that the electronic file is satisfactorily accessible to VTA at all times. Acceptable formats of the electronic file are Microsoft SharePoint, PlanGrid, DropBox, Apple iCloud, Microsoft OneDrive, Google Drive, or equivalent.

#### **6.14.4. Hazardous Substances Controls and Storage**

Contractor must not permit any Hazardous Substances to be brought onto or stored at the Worksite or used in connection with the Work, except for specified materials and commonly used construction materials for which there is no reasonable substitute. All such materials must be handled, stored and disposed of in accordance with all manufacturer's guidelines, warnings and recommendations and in full

compliance with all applicable laws. All notices required to be given with respect to such materials must be given by Contractor.

Contractor must not intentionally release or dispose any Hazardous Substance at the Worksite or into the soil, drains, surface or ground water, or air, nor may Contractor allow any subcontractor, or supplier or any other person for whose acts Contractor or any subcontractor, sub-subcontractor or supplier may be liable, to do so.

Hazardous Substances controls must conform to the applicable federal, state and local rules and regulations. All liquid Hazardous Substances and waste must be stored in double walled containers in accordance with all applicable federal, state and local Hazardous Substances (sometimes also referred to as "hazardous materials"), in addition to any permit or VTA specific requirements. If volatile and/or noxious substances are being used in spaces that are not naturally ventilated Contractor must provide adequate artificial ventilation.

#### **6.14.5. Written Safety Precautions**

Contractor must set forth in writing its safety precautions and programs in connection with the Work, which meets or exceeds any and all applicable laws, ordinances, rules, regulations, and orders of any public, quasi-public, or other authority relating to the safety of persons and their protection against injury, specifically including, but in no event limited to the following:

- (1) Federal Occupational Safety and Health Act of 1970, as amended,
- (2) The California Occupational Safety and Health Act of 1973, as amended and
- (3) The California Labor Code.

**In the event of conflicting requirements, the more stringent requirement governs.**

All Work, whether performed by Contractor, or its subcontractors of all tiers or anyone directly or indirectly employed by any of them, and all equipment, machinery, materials, tools and like items incorporated or used in the Work, must be in compliance with and conform to:

- (1) All applicable laws, ordinances, rules, regulations, and orders of any public, quasi-public, or other authority relating to the safety of persons and their protection against injury, specifically including, but in no event limited to, the above listed acts and associated standards and all rules and regulations now or hereafter in effect pursuant to said acts; and
- (2) Contractor must provide, or cause to be provided, to each worker on the Worksite the proper safety equipment for the duties performed by that worker and will not permit any worker on the Worksite who fails or refuses to use the same. VTA has the right, but not the obligation, to order Contractor to send a worker off the Worksite for the day or to discharge a worker for their failure to comply with safety practices.
- (3) Within 20 days of Notice to Proceed, Contractor must provide proper safety equipment and required Personal Protective Equipment (PPE) to key VTA staff as required for the safe inspection and oversight of the Work. Equipment must comply with the applicable OSHA level of protection required, as determined by VTA or by a certified industrial hygienist. If conditions change to require a higher level of protection PPE, Contractor must provide VTA revised PPE within 5 working days of determination of need for greater protection.
- (4) VTA's Procedure, Reflective Safety Vests, Document Number 600.009, which is referenced in **Appendix S VTA's Policy on Reflective Safety Vests.**

#### **6.14.6. Protection of Work and Property; Responsibility for Loss**

Contractor must, throughout the performance of the Work, maintain adequate and continuous protection of all Work and temporary facilities against loss or damage from whatever cause, protect the property of VTA and third parties from loss or damage from whatever cause arising out of the performance of Work and comply with the requirements of VTA and its insurance carriers, and with all applicable laws, codes, rules and regulations with respect to the prevention of loss or damage to property as a result of fire or other hazards to:

- (1) Employees on the Work and other persons who may be affected thereby;
- (2) The Work, materials and equipment to be incorporated therein, whether in storage on or off of the Worksite, under care, custody or control of Contractor and/or its sub-subcontractors;
- (3) Other property at the Worksite or adjacent thereto, such as trees, shrubs, lawns, walks, pavements, roadways, structures and utilities not designated for removal, relocation or replacement in the course of construction; and
- (4) Solvents, oils and any other substance that may be harmful to plant life must be disposed of in containers and removed from the Worksite. At completion of the Work, any contaminated soil must be removed and replaced with soil of equal quality prior to contamination by Contractor at no additional cost to VTA.

#### **6.14.7. VTA Patrols**

VTA may, but is not required to, make periodic patrols of the Worksite as a part of its normal security and safety program. In such event, however, Contractor is not relieved of its aforesaid responsibilities and VTA does not assume same, nor will it be deemed to have assumed, any responsibility otherwise imposed upon Contractor.

#### **6.14.8. Notice in Writing Before Breaking Ground**

Contractor must give notice in writing, at least forty-eight (48) hours before breaking ground, to all persons having interests on or near the Worksite, including public utility companies, owners of property having structures or improvements in proximity to the Worksite, superintendents, inspectors, or those otherwise in charge of property, streets, water pipes, gas pipes, sewer pipes, telephone cables, electric cables, railroads or otherwise who may be affected by Contractor's operation, in order that they may remove any obstruction for which they are responsible and have a representative on the Worksite to see that their property is properly protected. Such notice does not relieve Contractor of responsibility for any damages, claims, and defense of all actions against VTA, resulting from performance of such Work.

#### **6.14.9. Safeguards for Safety and Protection**

Contractor must erect and maintain, as required by existing conditions and performance of the Contract, reasonable safeguards for safety and protection, including posting danger signs and other warnings against hazards, promulgating safety regulations and notifying owners and users of adjacent Worksites and utilities.

#### **6.14.10. Job Safety Compliance**

Contractor is responsible for job safety in compliance with the following standards:

- National Electrical Code

- All CPUC General Orders including but not limited to 143 B, 164 E, 172 and 175A
- Cal/OSHA Title 8
- Fed OSHA Standard 29 CFR

#### **6.14.11. Damage to the Work**

Contractor must rebuild, repair, restore and make good all losses of, and injuries or damages to, the Work performed or any portion thereof (specifically including owner-supplied, equipment or other items to be utilized in connection with, or incorporated in, the Work) before final acceptance of the Work. Such rebuilding, repair or restoration will be at Contractor's sole cost and expense unless the loss, injury or damage requiring such rebuilding, repair or restoration is caused by a hazard against which VTA is required to insure provided, however, that if the loss, injury or damage would not have occurred but for the negligent act or omission of Contractor, and its subcontractors of any tiers or anyone directly or indirectly employed by any of them or for whose acts any of them may be liable, the rebuilding, repair or restoration will be at Contractor's cost and expense to the extent of the deductible in said insurance. If any policy of insurance covering loss or damage to the Work is voided due to any action of Contractor or any of its subcontractors of any tier, such rebuilding, repair or restoration will be at Contractor's sole cost and expense.

#### **6.14.12. Dangerous Conditions**

Contractor must designate the project superintendent, or such other qualified member of Contractor's organization at the Worksite as may be approved by VTA, to be responsible for the prevention of injuries and illnesses.

If VTA or any public agency with jurisdiction notifies Contractor of any claimed dangerous condition at the Worksite which is within Contractor's care, custody or control, Contractor must take immediate action to rectify the condition at no additional cost to VTA. Contractor is responsible for the payment of all fines levied against VTA for deficiencies relating to Contractor's supervision or conduct of the Work.

Contractor must not load or permit any part of the construction or Worksite to be loaded so as to endanger safety of persons or property.

Contractor must not permit open fires on the Worksite.

Use or storage of explosives is prohibited.

Contractor must return all improvements on or about the Worksite and adjacent property which are not shown to be altered, removed or otherwise changed to conditions that existed prior to Contractor's starting performance under the Contract.

#### **6.14.13. Emergencies**

In any emergency affecting the safety of persons or property, or in the event of a claimed violation of any Federal or State safety or health law or regulation, arising out of or in any way connected with the Work or its performance, Contractor must ensure that at least one of Contractor's employees with authority is on duty during working hours, and act immediately to prevent threatened damage, injury or loss or to remedy said violation, whichever is applicable, failing which VTA may immediately take whatever action it deems necessary, including, but not limited to, suspending the Work as provided in **Section 7.69 Suspension of the Work**. Contractor must also establish and maintain adequate First Aid facilities at locations close to work areas, and mark such locations with signs of adequate size and composition.

Contractor must also ensure that at least one of Contractor's employees qualified by a recognized authority to perform First Aid is on duty while Work is being performed

VTA may offset any and all costs or expenses of whatever nature, including attorneys' fees, paid or incurred by VTA in taking such actions against any sums then or thereafter due to Contractor.

#### **6.15. Reserved**

#### **6.16. Access and Working Hours**

This facility is owned and operated by VTA seven (7) days per week. Contractor must minimize its disruption to VTA personnel and will carefully schedule its Work operation with VTA's Resident Inspector.

Refer to **Section 6.11.1 Construction Hours** for additional requirements.

#### **6.17. Contractor Cooperation and Coordination**

Contractor will meet weekly with the Resident Inspector, Project Manager and affected subcontractors to review construction status problems, schedule, concerns, etc. and to resolve any outstanding issues. The date and time of this weekly meeting will be established by the Resident Inspector at the Pre-Construction Meeting.

#### **6.18. Substantial Completion and Acceptance**

In addition to the requirements outlined in **Section 7.55 Final Inspection and Acceptance of All or a Portion of the Work**, the following apply:

##### **6.18.1. Substantial Completion**

Substantial Completion will be deemed to have occurred only when all of the following conditions have been satisfied:

- Contractor completes all Work except for punch list items, final cleanup and other items included in the requirements for Final Acceptance;
- Contractor has completed all electrical and system work to level of completion ready for integration and testing and permission to operate from PG&E;
- Contractor has ensured that all Work has been performed in accordance with the requirements of the Contract Documents;
- Contractor has ensured that the Project may be used without damage to the Project or any other property on or off the Worksite, and without injury to any person;
- Contractor will have furnished to VTA for VTA's approval certificates that the Work is in conformance with all applicable design criteria, applicable codes and Governmental Rules;

##### **6.18.2. Punch List Items**

Contractor must submit a proposed Punch List to VTA when Contractor believes the Project has been substantially completed in compliance with the Contract. The "Punch List" will be a statement of repairs, corrections and adjustments to the Contract Work, and incomplete aspects of the Project which, in Contractor's opinion, can be completed with minimal interference to the occupancy, use and operation of the completed facility.

All Punch list items will be completed to the reasonable satisfaction of VTA

### **6.18.3. Final Acceptance**

Contractor will achieve Final Acceptance by meeting the following requirements, in addition to the requirements as outlined in **Section 7.55 Final Inspection and Acceptance of All or a Portion of the Work:**

- All requirements for Substantial Completion and Punch List Completion have been fully satisfied;
- All spare parts, if any, have been purchased and delivered to VTA free of liens;
- Contractor will have delivered to VTA a certification representing that there are no outstanding claims of Contractor or claims, Liens or stop payment notices of any Subcontractor or laborer with respect to the Work, other than any previously submitted unresolved claims of Contractor and any claims, Liens or stop payment notices of a Subcontractor or laborer being contested by Contractor (in which event the certification must include a list of all such matters with such detail as is requested by VTA and, with respect to all Subcontractor and laborer claims, Liens and stop payment notices, must include a representation by Contractor that it is diligently and in good faith contesting such matters by appropriate legal proceedings which will operate to prevent the enforcement or collection of the same). For purposes of such certificate, the term "claim" will include all matters or facts which may give rise to a claim;
- VTA will have received and accepted all Construction Documents, Record Documents and as-built schedule, test data and other deliverables required under the Contract Documents;
- All of Contractor's obligations under the Contract Documents (other than obligations which by their nature are required to be performed after Final Acceptance) must have been satisfied in full or waived in writing by VTA; and
- Contractor will have delivered to VTA a Notice of Completion for the Project in recordable form and meeting all statutory requirements.

### **6.19. Final Pay Quantities**

When the estimated quantity for a specific portion of the Work is designated on the plans or in the Schedule of Quantities and Prices as a final pay quantity (F), the estimated quantity will be the final quantity for which payments for the specific portion of the Work will be made, unless the dimensions of the portion of the Work shown on the plans are revised by VTA, or unless the portion of the Work is eliminated. If the dimensions of the specific portion of the Work are revised, and the revisions result in an increase or decrease in the estimated quantity of the portion of the Work, the final quantity for payment will be revised in the amount represented by the changes in the dimensions. If the specific portion of the Work is eliminated, the final pay quantity designated for the specific portion of the Work will be eliminated. In the event that the quantity of a final pay item shown on the Schedule of Quantities and Prices differs from a quantity that can be calculated from dimensions or lines shown on the Plans, the quantity shown on the Schedule of Quantities and Prices will govern.

When portions of an item have been designated on the plans or in the Schedule of Quantities and Prices as final pay quantities, portions so designated will be measured and paid for in accordance with the provisions of **Section 7.59 Progress Payments**.

## 6.20. Project Close-Out Requirements – Record Drawings

During the project, Contractor must keep a master set of drawings updated, noting any variation of the Work. Upon completion of the Work, Contractor must produce a master “Record” set of plans by neatly transferring all such noted variations to clean, high resolution, full-size (22”x34”) hard copies of the same drawings, and must deliver same to VTA for signed receipt, review, and certification. VTA will accept electronic submission of the required documents, where consistent with the other requirements of the Contract, and where the quality of the electronic record drawings meets or exceeds that of the required high resolution, full size hard copies.

Record Drawings will include all shop drawings submittals indicated as NO EXCEPTIONS TAKEN (NET) and MAKE CORRECTIONS NOTED (MCN). Shop Drawings indicated as MAKE CORRECTIONS NOTED (MCN) must be revised to reflect the required corrections or modifications.

In addition, project closeout will include marked specifications, drawings submitted as part of design reviews, design calculations, test procedures and results, subcontracts, purchase orders, employment records, shop drawings, change orders, daily logs and certificates of inspections, and other items pertinent to the installed and tested contract Work.

Refer to **Section 8 Technical Specifications, Section 01 78 39 – Project Record Documents** for additional information and requirements.

## 6.21. Progress Schedule

### 6.21.1. General Requirements

- (a) **Critical Path Method.** Scheduling of Work must be performed by Contractor in accordance with this Section 6.21 Progress Schedule.

Development of the schedule and project status reporting requirements must employ computerized Critical Path Method (CPM) scheduling.

- (b) **Primavera.** All Schedules must be prepared using the latest version of “Primavera” software.
- (c) **Incorporation of Contract Requirements.** All schedules prepared by Contractor must meet the requirements for access, sequencing, construction staging, delivery of Contractor and VTA-furnished materials, Contract milestone and completion dates as specified in the Contract Documents.
- (d) **Contractor’s Representation.** Submittal of the baseline CPM schedule (“Baseline”) and subsequent schedule updates (“Updates”) will be Contractor's representation that the submitted schedule meets all of the requirements of the Contract and that Contractor plans to execute the Work in the sequence, durations, and methods indicated on the submitted Baseline and Updates.
- (e) **Submittal Format.** Unless otherwise specified in this Section 6.21 Progress Schedule, procedures for the submission, review and acceptance of all schedule submittals will be in accordance with Section 6.6 Contract Data Requirements. Contractor must submit three (3) copies of each schedule submittal and an electronic copy of the exported schedule data file on compact disk or other acceptable electronic medium for all schedule submittals.

Schedule submittals includes Baseline, monthly updates, schedule revisions, recovery schedules, Time Impact Evaluations, and mitigation plans.



- (f) **Current Schedule.** Contractor will develop the schedule and monitor the actual progress of the Work. The accepted Baseline, together with the most recent accepted Update constitute the “Current Schedule”. The Current Schedule will be the basis for evaluating progress and time extension requests.
- (g) **Acceptance No Waiver.** Acceptance of Preliminary and Baseline schedules and updates by VTA does not constitute a waiver of any Contract requirement including the Contract completion and milestone dates. Neither schedule inaccuracies nor Contractor’s failure to include in the schedule an element of the Work will relieve Contractor from responsibility for accomplishing the Work in accordance with the Contract requirements.
- (h) **Pay Item.** The Schedule pay item includes full compensation for all costs associated with schedule submittals and re-submittals and no additional compensation will be allowed therefor.
- (i) **Schedule Adjustments.** VTA reserves the right to require that Contractor modify, adjust, add to, or clarify any portion of the Current Schedule which may later be discovered to be insufficient or inaccurate for planning, monitoring, or prosecuting the Work. No additional compensation will be provided for such modifications, adjustments, additions, or clarifications.

#### **6.21.2. Reserved**

#### **6.21.3. Schedule Float**

- (a) **Definition.** “Float” is the amount of time between the early and late start dates of an activity, or between the early and late finish dates of the activity in the CPM schedule. A Baseline with negative float will not be accepted.
- (b) **Ownership.** Neither VTA nor Contractor owns Float; the project owns Float. As such, Float is considered an expiring resource available to both parties.
- (c) **Early Completion.** If Contractor submits a schedule showing completion dates earlier than the dates specified in **Section 6.4 Time for Performance** and **Section 6.11 Work Sequence and Constraints**, VTA may, in its discretion, accept or reject the schedule. If the schedule showing early completion is accepted, VTA may, in its discretion, issue a change order adjusting the Contract dates. However, if a change order is issued, no additional compensation will be provided to Contractor for such adjustment to the Contract. If VTA elects not to issue a change order adjusting the Contract dates, any additional time between the early and contract completion dates will be Float. Neither party will be liable to the other for impacts to early completion dates.

#### **6.21.4. Reserved**

#### **6.21.5. Baseline CPM Schedule**

- (a) **Submittal.** Contractor must prepare and submit for acceptance by VTA, a detailed Baseline as further specified in **Appendix B, Table B-2 Technical Submittals List**. The Baseline must be an orderly and practical plan for completion of the Work in conformance with all Contract requirements. The date of the Baseline will be the date of Notice of Award.

- (b) **Format and Content.** The Baseline must be comprehensive. It must include all activities necessary to clearly establish the critical path and to demonstrate complete and accurate planning and sequencing of the Contract and to permit monitoring and evaluation of progress and time impacts.

The Baseline must be time-scaled and comply with the following requirements:

- All activities in the schedule, with the exception of the first and last activities, must have a minimum of one predecessor and a minimum of one successor.
  - The Baseline must not show a duration longer than 15 days for any activity except submittals, approvals, fabrication and procurement, unless otherwise approved by VTA. An activity “duration” is the total number of actual working days required to perform that activity including the first day thereof.
  - Include a Special Calendar for those activities susceptible to weather delays. The Special Calendar must incorporate the number of working days that are anticipated will be lost due to adverse weather conditions in accordance with **Section 6.21.12 Adverse Weather Delays**.
  - Identify procurement of substantial items of material and equipment and, include as separate activities the following: submittal, review, approval, order, delivery and inspection at the Worksite. The timing and duration for VTA review and approval of submittals and shop drawings will be as specified in Section 8.0 - Technical Specifications and the Technical Submittals List.
  - Identify VTA-furnished materials and equipment, if any, as separate activities.
  - Show dependencies (or relationships) between activities.
  - Include Contractor testing, VTA testing, training of VTA personnel, delivery of spare parts, submittal of operating and maintenance manuals, developing and completing punch list items, and clean-up as separate activities.
  - Show the interface with the work of other contractors and agencies, including utilities.
  - Identify all activities to be performed by subcontractors by name of subcontractor.
  - Identify all anticipated non-working days and holidays.
- (c) **Baseline Report.** Contractor must submit with the Baseline a report containing the following information: (i) A list of activities, showing the early, late and actual start and finish dates, duration, float, responsibility code and the predecessor and successor relationship, sorted by early start; (ii) A time-scaled network diagram that includes activities and their relationships; and (iii) A written narrative which describes the basis, assumptions, planned sequence of work operations, production rates, equipment, resources, constraints, and any other considerations used to develop the Baseline.
- (d) **Review and Resubmittal.** VTA will review and provide comments on the Baseline within 14 days of receipt. Contractor must revise and resubmit the Baseline to address all comments, concerns and modifications requested by VTA within 14 days of receipt of VTA comments. Contractor must include with the Baseline re-submittal a line-by-line response to each VTA comment indicating how it has been addressed by Contractor.

### 6.21.6. Schedule Update

- (a) **Submittal.** Following acceptance of the Baseline, Contractor must prepare and submit monthly schedule updates ("Updates") to reflect actual progress, anticipated changes to planned activities, and corrections to out-of-sequence logic. Five days before the end of each month VTA will meet with Contractor and its Scheduler to review the progress of activities and Contractor's proposed logic revisions for that month. Updates will be statused through the end of the month and must be submitted within 7 calendar days following the end of the month
- (b) **Content.** Each Update must show all work activities including those already completed. Completed activities must incorporate "As-Built" information including when activities were actually started and completed, logic revisions, and activity re-sequencing. The Weather Delay Calendar must be revised to include actual weather delay days that occurred during the reporting period.
- (c) **Update Report.** A report must be submitted with the Update containing the following information: (i) A list of activities, showing the early, late and actual start and finish dates, duration, float, responsibility code and the predecessor and successor relationship, sorted by early start; (ii) A time-scaled network diagram that includes activities and their relationships, and (iii) A written narrative which includes:
- Status of major project components (percent complete, amount of time ahead or behind schedule) and an explanation of how the Project will be brought back on schedule if delays have occurred.
  - Progress made on critical activities.
  - An explanation for lack of progress on critical path activities that were planned to be performed during the previous month.
  - An explanation for any schedule changes, including changes to logic or to activity durations.
  - List of critical activities scheduled to be performed in the next three (3) week period.
  - Status of major material and equipment procurement.
  - Any delays encountered during the month.
  - List of any working days lost due to weather and changes made to the weather delay calendar.
  - Any other information pertinent to status of the Contract. Contractor must include additional status information requested by VTA at no additional cost.
- (d) **Acceptance.** VTA will, within 14 working days after receipt of the Update, either accept, accept with comments, or reject the submittal: (i) If accepted, no additional action by Contractor is required for that month; (ii) If accepted with comments, the requested revisions must be incorporated into the next Update. Failure to incorporate the requested revisions into the subsequent Update will be cause for rejection of the subsequent Update; or (iii) If rejected, within five calendar days, Contractor must provide a separate line-by-line response to all comments and re-submit the Update incorporating the requested revisions. Only one

(1) Update re-submittal per month will be reviewed by VTA. If an Update is not accepted, the amount of that month's schedule installment payment will be deducted from the Contract (see **Section 6.21.13 Payment Provisions**).

(e) **Current Schedule.** The accepted Update will become the Current Schedule.

#### **6.21.7. Three-Week Look-Ahead Schedule**

(a) **Project Meetings.** At the weekly progress meeting (see **Section 7.27 Project Meetings**), Contractor will provide a time-scaled Three Week Look-Ahead Schedule ("Three Week Schedule"). The Three Week Schedule must show the actual progress for the previous week and planned activities for the upcoming three weeks.

(b) **Primavera.** The Three Week Schedule will be prepared using "Primavera" software. Handwritten schedules will not be accepted by VTA. VTA may request electronic transmittal of the Three Week Schedule by compact disk or other electronic medium acceptable to VTA, at least one day ahead of the weekly progress meeting.

(c) **Consistency.** The activities in the Three Week Schedule will be based upon and correlated by activity number to the Current Schedule. The actual progress data incorporated into the Update and the Current Schedule must be consistent with the data previously shown in the Three Week Schedules. The format of the Three Week Look-Ahead Schedule will be subject to review and acceptance by VTA.

#### **6.21.8. Schedule Revisions**

(a) **Significant Changes.** If Contractor desires to make a change in the method or manner of construction that results in significant changes to the logic, sequence or duration of scheduled activities, Contractor must submit a request for a schedule revision to VTA. Contractor must not revise the Current Schedule until the proposed revision has been accepted by VTA.

(b) **Format of Request.** To request a revision to the Current Schedule, Contractor must provide VTA with a written narrative that includes a description and reason for each proposed revision. Contractor must also provide a time-scaled logic diagram which compares the original sequence and durations to the revised sequence of work and activity duration.

(c) **VTA Response.** VTA will respond to the request for revision within 14 days. Contractor must submit any objections to VTA's response in writing within 7 days of receipt and must include any additional information it wishes VTA to consider in connection with the request for revision. Thereafter, VTA's determination on the request for revision will be final and the schedule will be updated in accordance therewith.

#### **6.21.9. Recovery Schedule**

(a) **Submittal.** If an Update shows a date for final completion or for any of the milestones beyond the Contract dates, Contractor must, within 7 days after submittal of the Update, submit a Recovery Schedule. Contractor's submittal must explain the methodology, basis and assumptions used in the Recovery Schedule. If sequence changes are proposed, Contractor must provide a schedule diagram comparing the original sequence to the proposed sequence of work.

- (b) **Acceptance.** Contractor must incorporate any revisions to the Recovery Schedule requested by VTA. The Recovery Schedule will not be incorporated into the Current Schedule until accepted by VTA. Change Requests and Change Notices
- (c) **Change Requests and Change Notices.** Contractor must follow the procedures of **Section 7.65 Change Requests and Change Notices** for any changes to the Work that Contractor contends results in additional cost. Contractor's failure to submit a timely Change Request will constitute a waiver of any and all such costs and claims associated therewith including anticipated profits.

#### **6.21.10. Time Impact Evaluation for Change Orders and Delays**

- (a) **Submittal.** When Contractor becomes aware of circumstances that it considers a change to the contract resulting in delay (including Change Notices and Force Account directives), Contractor must prepare and submit a Time Impact Evaluation (TIE). The TIE must include both a written narrative and schedule diagram that shows how Contractor proposes to incorporate the change into the Current Schedule and how it impacts the critical path.
- (b) **Preparation Costs.** Contractor must be responsible for all costs associated with the preparation of TIE's and the process of incorporating them into the Current Schedule.
- (c) **Acceptance.** Once accepted by VTA, the TIE must be incorporated into the next Update at no additional cost to VTA. If Contractor and VTA are unable to reach agreement, Contractor must incorporate changes in accordance with VTA's direction.
- (d) **Time for Submittal/Waiver.** Contractor must submit a TIE within 15 days of the circumstances giving rise to the change. Contractor's failure to submit a timely TIE in connection with a change causing delay will constitute a waiver of any and all rights to a time extension, and all claims based thereon, including anticipated profits, for that change.

#### **6.21.11. Time Extensions**

- (a) **Timely Request/ Waiver.** Contractor must request a time extension in accordance with **Section 6.21.10 Time Impact Evaluation for Change Orders and Delays** for any change, delay, or disruption that impacts a completion date of the Current Schedule. Contractor's failure to request a time extension within 15 days of the circumstances causing the delay will constitute a waiver of any and all rights to a time extension, compensation, and any and all claims, including but not limited to time-related overhead, indirect impacts, cumulative impacts, constructive acceleration, and loss of anticipated profits, based thereon, for that delay.
- (b) **Contractor Without Fault.** A time extension will be granted only if the change, delay, or disruption that impacts a completion date is beyond the control and without the fault or negligence of Contractor or any subcontractor and impacts the Critical Path.
- (c) **Compensable Delays.** A delay is compensable to Contractor only if it: (i) is caused by VTA; (ii) is not concurrent with Contractor's caused delays or delays that are excusable but non-compensable (e.g. weather delays); and (iii) impacts the Critical Path.
- (d) **Non-Compensable Delays.** A delay caused by VTA is non-compensable if it is concurrent with Contractor caused delays or delays that are excusable but non-compensable.
- (e) **Mitigation Plan.** For any delay for which Contractor feels they are entitled to a time extension, Contractor must, within 15 days of the events causing the delay, submit to VTA a

mitigation plan, including a schedule diagram, which explains how the impact can be mitigated. Contractor must also include a detailed cost breakdown of the labor, equipment and material required to mitigate the delay. Contractor is responsible for the cost to prepare the mitigation plan. VTA will review and comment on the time extension and mitigation plan. Within 15 days VTA will accept, accept with comments or reject the time extension and mitigation plan.

#### **6.21.12. Adverse Weather Delays**

- (a) **Typical Inclement Weather Days.** Contractor will assume and incorporate into all Schedules the typical number of working days lost as a result of inclement weather shown on the table set forth below. Only working days lost as a result of inclement weather in excess of those listed for a given month will be considered for a time extension. Typical weather days for a given month, which are not actually lost, will not be carried over to any other month.

##### Typical Number of Working Days Lost to Weather

<u>Month</u>	<u># of Days</u>
January	5
February	5
March	5
April	4
May	3
June	0
July	0
August	0
September	0
October	0
November	3
December	5

- (b) **Effect on Critical Path Activities.** A working day will not be deemed lost as a result of inclement weather, and therefore eligible for a time extension, unless at least 60% of Contractor's planned work forces are unable to be employed on the critical path activities. Weather delays may consist of days lost during inclement weather, days lost because of wet soil, and days lost because of site clean-up after inclement weather.
- (c) **Time Extensions for Weather Delay.** Contractor must establish all of the requirements of this Section and comply with **Section 6.21.11 Time Extensions** for a time extension based on weather delay.
- (d) **Non-Compensable.** All time extensions granted for weather delays will be non-compensable.

#### **6.21.13. Payment Provisions**

- (a) **Administration of Pay Item.** If the contract contains a separate pay item for "Progress Schedule", that pay item will be administered as follows: (i) 25% may be invoiced upon acceptance of the Baseline, and (ii) the remaining 75% may be invoiced in equal monthly installments for each accepted Update thereafter. The equal monthly invoice amounts will be determined by dividing the remaining pay item amount by the number of months from the date of acceptance of the Baseline, or sixty (60) days from the first charged day, whichever is

earlier, through contract completion. The final installment may not be invoiced until after final acceptance of the Contract and a final As-Built schedule is received. There will be no separate payment for any other required schedule submittal.

- (b) **Deductions.** If Contractor fails to submit the Baseline within sixty days from the first charged day, Contractor will not be entitled to payment for the Baseline and therefore 25% of the total amount of the "Progress Schedule" pay item will be deducted from the Contract. Thereafter, each month Contractor fails to submit an accepted Update, Contractor will not be entitled to payment for that Update and the amount of that monthly installment payment will be deducted from the Contract. Forfeiture of any payments will not relieve Contractor from the responsibility to submit the CPM schedule update and all other requirements of this section including weekly schedule reports, daily Contractor construction reports, time impact evaluations and recovery schedules throughout the term of the contract, including the final As-Built schedule.
- (c) **Special Retention.** In addition to the amount retained by VTA, if any, from each progress payment as provided for in **Section 7.59 Progress Payments**, VTA may withhold additional amounts, not to exceed 10% of the total progress payment, for Contractor's failure to meet the requirements of **Section 6.21 Progress Schedule**. VTA will pay Contractor the amount withheld once VTA has determined that Contractor has satisfactorily complied with the requirements of **Section 6.23 Progress Schedule**.

## 6.22. References to Days

A "**working day**" is defined to mean any day not a Saturday, Sunday, or **holiday**, unless otherwise indicated. All references to "**days**" herein are references to "**calendar days**", unless otherwise indicated.

For the purposes of this contract document, recognized holidays will be:

- New Year's Day (January 1),
- Martin Luther King, Jr. Day (3rd Monday in January),
- President's Day (the third Monday of February),
- Cesar Chavez Day (March 31),
- Memorial Day (the last Monday in May),
- Independence Day (July 4),
- Labor Day (the first Monday of September) (triple time)
- Veterans Day (November 11)
- Thanksgiving Day (the 4th Thursday in November)
- The day after Thanksgiving (Friday)
- Christmas Day (December 25)

If a holiday falls on a Sunday, the following Monday will be deemed to be the holiday in lieu of the day observed. If a holiday falls upon a Saturday, the preceding Friday will be deemed to be the holiday in lieu of the day observed.

**6.23. Reserved**

**6.24. Reserved**

**6.25. Reserved**

**6.26. Quality Assurance and Quality Control Requirements**

Contractor must, at its own expense, submit for VTA's review and approval, a Quality Assurance program consistent with the requirements as specified in **Appendix M Quality Assurance and Quality Control Requirements** and these specifications.

**6.27. Environmental Coordination and Cooperation**

Attention is directed to **Appendix G Environmental Coordination and Cooperation** of these Contract Documents for a complete listing of environmental requirements applicable to the project. Contractor is advised to become thoroughly familiar with the information, processes and forms, submittal requirements, and compliance requirements in **Appendix G Environmental Coordination and Cooperation**.

**6.28. Reserved**

**6.29. Reserved**

**6.30. Compliance and Testing for Highway and Transit Pavement**

**Section 7.49 Certificates of Compliance and Testing** includes specific testing and compliance requirements. In addition to **Section 7.49 Certificates of Compliance and Testing**, the following requirement applies for highway and transit pavement Work.

VTA has adopted methods for testing the quality of materials and work. These methods are identified by number and are referred to in Section 8 Technical Specifications as the California Test. Copies of individual California Tests are available and will be furnished to interested persons upon request.

Whenever the specifications require compliance with specified values for the following properties, tests will be made by the California Test indicated unless otherwise specified:

<u>Properties</u>	<u>California Test</u>
Relative Compaction	216 or 231
Sand Equivalent	217
Resistance (R-value)	301
Grading (Sieve Analysis)	202
Durability Index	229

Whenever a reference is made in the specifications to a California Test by number, it will mean the California Test in effect on the day the Notice of Award for the Work is dated.

Whenever the specifications provide an option between two (2) or more tests, VTA will determine the test to be used.



Whenever a reference is made in the specifications to a specification, manual, or test designation either of the American Society of Testing and Materials, the American Association of State Highway and Transportation Officials, Federal Specifications, or any other recognized national organization, and the number or other identification representing the year of adoption or latest revision is omitted, it will mean the specification, manual, or test designation in effect on the day the Notice to Bidders is dated. Whenever said specification manual or test designation provides for test reports (such as certified mill test reports) from the manufacturer, copies of such reports, identified as to the lot of material, must be furnished to VTA. When material which cannot be identified with specific test reports is proposed for use, VTA may, at its discretion, select random samples from the lot for testing. Test specimens from the random samples, including those required for retest, must be prepared in accordance with the referenced specification and furnished by Contractor at their own expense. The number of such samples and test specimens will be entirely at the discretion of VTA.

*[This Page Intentionally Left Blank]*

## SECTION 7 GENERAL CONDITIONS

### LEGAL RESPONSIBILITIES AND RELATIONSHIPS

#### **7.1. Applicable Law and Jurisdiction**

This Contract incorporates provisions required by the laws of the State of California and the Federal Government. It will be Contractor's responsibility to determine the applicability of State and Federal laws, rules and regulations to the Work.

This Contract will be governed by California law. Any lawsuit or legal action arising from this Contract must be commenced and prosecuted in the courts of Santa Clara County, California.

#### **7.2. Compliance with Laws and Regulations**

Contractor shall keep itself informed of, comply with, and shall cause all of its agents, employees, suppliers and subcontractors of any tier, to observe and comply with all applicable Federal, State, and local laws, regulations, and policies, including, but not limited to, all applicable terms and conditions prescribed for third party contracts by the U.S. Department of Transportation ("DOT"). Contractor must indemnify, defend, and hold harmless VTA or any entity within whose jurisdiction or on whose property the Work is being performed, and (as applicable) their Board of Supervisors, Board of Directors or Councils as well as their officers, agents, consultants and employees from any claim, liability, loss, injury or damage arising out of, or in connection with, the performance of this Contract by Contractor and/or its agents, employees, suppliers or subcontractors of any tier, excepting only loss, injury or damage caused by the active or sole negligence or willful misconduct of personnel employed by the indemnitees.

#### **7.3. Contractor Licensing Requirements**

Contractors are required by law to be licensed in the State of California and are regulated by the Contractors State License Board. Frequently asked questions are posted at the CSLB website at <http://www.cslb.ca.gov/>. Any other questions related thereto may be referred to the Registrar of the Board whose address and contact information may be found at the CSLB website or use this address:

Contractor's State License Board  
9821 Business Park Drive  
Sacramento, CA 95827

#### **7.4. Independent Contractor**

Contractor represents that it is fully experienced and properly qualified to perform the class of work provided for herein, and that it is properly licensed, equipped, organized and financed to perform such work. Contractor will act as an independent Contractor and not as the agent or employee of VTA in performing the Contract, maintaining complete control over its employees. Nothing contained in this Contract or any subcontract awarded by Contractor will create any contractual relationship between any such subcontractor and VTA, and Contractor will perform all Work in accordance with its own methods subject to compliance with the Contract.

## **7.5. Permits, Licenses, Fees and Notices**

As specified in **Section 6 Special Conditions**, or as otherwise required by law, Contractor must, before beginning any work which requires a permit or similar authorization, secure and pay for all necessary licenses, fees, bonds, charges, inspections, customs or import duties, permits, and similar authorizations from all governmental authorities required to fulfill the Contract requirements and Contractor's obligations.

## **7.6. Nondiscrimination**

Contractor must comply with Section 1735 of the California Labor Code, which reads as follows:

“A Contractor shall not discriminate in the employment of persons upon public works on any basis listed in subdivision (a) of Section 12940 of the Government Code, as those bases are defined in Sections 12926 and 12926.1 of the Government Code, except as otherwise provided in Section 12940 of the Government Code. Every Contractor for public works who violates this section is subject to all the penalties imposed for a violation of this chapter.”

In the performance of this Contract, Contractor and its subcontractors will not unlawfully discriminate, harass or allow harassment, against any employee or applicant for employment because of sex, gender, gender identity, gender expression, race, color, ancestry, religious creed, national origin, physical disability (including HIV and AIDS), mental disability, medical condition (cancer), genetic information, marital status, age (over 40), sexual orientation, military and veteran status, and the denial of family care leave. Contractor and its subcontractors must ensure that the evaluation and treatment of their employees and applicants for employment are free from such discrimination and harassment. Contractor and its subcontractors must comply with the provisions of the Fair Employment and Housing Act (Government Code §12900 *et seq.*) and the applicable regulations promulgated thereunder (California Code of Regulations, Title 2, Section 7285.0 *et seq.*). The applicable regulations of the Fair Employment and Housing Commission implementing Government Code Section 12290 (a-f), set forth in Chapter 5 of Division 4 of Title 2 of the California Code of Regulations are incorporated into this Contract by reference and made a part hereof as if set forth in full. Contractor and its subcontractors must give written notice of their obligations under this clause to labor organizations with which they have a collective bargaining or other agreement. Contractor must include the nondiscrimination and compliance provisions of this clause in all subcontracts to perform work under this Contract. Contractor and its subcontractors must permit access to all records of employment, employment advertisements, application forms, and other pertinent data and records by the State Fair Employment Practices and Housing Commission, or any other agency of the State of California designated by the State, for the purpose of investigation to ascertain compliance with this clause.

## **7.7. Prohibited Interests**

### **7.7.1. Solicitation**

Contractor warrants that it has not employed or retained any company or person, other than a bona fide employee working solely for Contractor, to solicit or secure this Contract, and that it has not paid or agreed to pay any company or person, other than a bona fide employee working solely for Contractor, any fee, commission, percentage, brokerage fee, gift or any other consideration, contingent upon or resulting from the award or making of this Contract. For breach or violation of this warranty, VTA has the right to rescind this Contract without liability.

### **7.7.2. Interest of Public Officials**

No Board Member, officer, or employee of VTA during his or her tenure or for two (2) years thereafter is permitted to have any interest, direct or indirect, in this Contract or the proceeds thereof. If Contractor becomes aware of the existence of such an interest, Contractor must notify VTA of such interest within 1 business day of Contractor being made aware thereof.

### **7.7.3. Interests of Contractor**

Contractor covenants that, presently, Contractor, its officers, directors, or agents, have no interest and will not acquire any interest, direct or indirect, that would conflict in any manner or degree (or create an appearance of conflict) with the performance of the Contract. Contractor further covenants that in the performance of this Contract, Contractor will not knowingly employ any person having any such interest.

## **7.8. Labor Provisions**

### **7.8.1. Register with DIR**

Contractor and its subcontractors must be registered at the time of Bid Opening with the Department of Industrial Relations (DIR). The registration form may be found at: [www.dir.ca.gov/PublicWorks/PublicWorks.html](http://www.dir.ca.gov/PublicWorks/PublicWorks.html)

### **7.8.2. Safety**

Pursuant to Section 107 of the Contract Work Hours and Safety Standards Act and Department of Labor Regulations at 29 CFR Part 1926, no laborer or mechanic working on this Contract shall be required to work in surroundings or under working conditions that are unsanitary, hazardous, or dangerous to their health and safety as determined under applicable health standards promulgated by the Secretary of Labor.

In addition to Contractor's own safety procedures, and any safety procedures required under federal, state, or local laws or regulations, including compliance with the provisions of the California Occupational Safety and Health Act of 1973 and any additional safety requirements contained in this **Section 6 Special Conditions**, Contractor shall implement and enforce all safety requirements that are determined by VTA's Safety Coordinator to be applicable to the performance of any Work under this Contract.

### **7.8.3. Overtime Requirements**

Neither Contractor nor any subcontractor of any tier shall require or permit any worker to work in excess of eight hours in any single calendar day or in excess of 40 hours in any single calendar work week (defined as seven sequential calendar days) unless such worker receives compensation at a rate not less than one and one-half times the basic rate of pay for all hours worked in excess of eight hours in any single calendar day or in excess of 40 hours in any single calendar work week, whichever is greater. Failure to comply with the preceding requirements shall subject Contractor or any subcontractor of any tier to the penalties specified in Labor Code §1813.

### **7.8.4. Prevailing Wage Rates**

Pursuant to appropriate Sections of the Labor Code of the State of California, the Director of the California Department of Industrial Relations has ascertained the general prevailing rate of wages (which rate includes employer payments for health and welfare, vacation, pension, and similar purposes) applicable to the Work to be performed under this Contract, for straight time, overtime, Saturday, Sunday and holiday work. Said prevailing wage rates are incorporated herein by reference. These wage rates are on

file and will be made available to any interested party on request in the Procurement, Contracts and Materials Management Office of VTA, Building A, First Floor, 3331 N. First Street, San José, CA 95134. These wage rates are also available through the California State Department of Industrial Relations at <http://www.dir.ca.gov>. Contractor shall post a copy of the prevailing wage rates at the jobsite or material staging area. The Work is subject to compliance, monitoring and enforcement by the California Department of Industrial Relations.

Workers employed in the Work must be paid at the rates at least equal to the prevailing wage rates as adopted. If Contractor uses a craft or classification not shown on the prevailing wage determinations, Contractor may be required to pay the wage rate of that craft or classification most closely related to it as shown in the general determinations effective at the time of Contract award.

Failure to pay such prevailing wages shall subject the employer to the penalties set forth in Labor Code §1775.

If **Section 1.8** and **Section 3.7** identify this project as a recipient of Federal Assistance, then this Contract is also subject to Federal requirements for payment of prevailing wages as determined by the Secretary of Labor. Where there are differences in the rates, the higher shall apply.

#### **7.8.5. Liability for Unpaid Wages**

In the event of any violation of the clause set forth in subparagraph (b) (1) of 29 CFR Section 5.5, Contractor and any subcontractor responsible hereunder shall be liable for the unpaid wages.

#### **7.8.6. Withholding for Unpaid Wages and Liquidated Damages**

The U.S. DOT or VTA may upon its own action or upon written request of an authorized representative of the Department of Labor withhold or cause to be withheld, from any monies payable on account of Work performed by Contractor or subcontractor under this Contract or any other Federal contract with Contractor, or any other Federally-assisted contract subject to the Contract Work Hours and Safety Standards Act, which is held by Contractor, such sums as may be determined to be necessary to satisfy any liabilities of such Contractor or subcontractor for unpaid wages and liquidated damages as provided in the clause set forth in subparagraph (b) (2) of 29 CFR Section 5.

#### **7.8.7. Travel and Subsistence Payments**

Pursuant to Labor Code §1773.8, Contractor shall be liable for travel and subsistence payments to each worker needed to execute the Work, as such travel and subsistence payments are defined in the applicable collective bargaining agreements filed in accordance with the provisions of Labor Code §1773.8.

#### **7.8.8. Retention of Labor Records**

In the performance of the Work, Contractor shall be responsible for compliance with California Labor Code Section 1776 pertaining to payroll records. Contractor and all of its subcontractors of any tier shall maintain all payrolls and basic payroll records during the course of the Work and shall preserve them for a period of three years from the completion of the Contract. Such records shall contain the name, address, social security number, work classifications, straight time and overtime hours worked each day and week, and the actual per diem wages paid to each journeyman, apprentice, worker or other employee employed by Contractor and all of its subcontractors of any tier in connection with the Work. These records shall be made available by Contractor or any of its subcontractors of any tier for inspection, copying, or transcription by authorized representatives of DOT, VTA or the Department of Industrial Relations, and

Contractor or any of its subcontractors of any tier shall permit such representatives to interview employees during working hours on the job.

#### **7.8.9. Employment of Apprentices**

In the performance of the Work, Contractor shall be responsible for compliance with California Labor Code Section 1777.5, pertaining to the employment of registered apprentices.

#### **7.8.10. Subcontracts**

Contractor shall insert in all of its subcontracts the clauses set forth in this **Section 7.8 Labor Provisions** and also a clause requiring its subcontractors to include these clauses in any lower tier subcontracts. Contractor shall be responsible for compliance by any subcontractor or lower tier subcontractor with the clauses set forth in this **Section 7.8 Labor Provisions**. Contractor is prohibited from performing the Work with a subcontractor who is ineligible to perform work on a public works project pursuant to Sections 1777.1 or 1777.7 of the California Labor Code.

#### **7.9. Hazardous Materials or Unusual Conditions**

In the event underground tanks, vaults, materials or unusual conditions as specified in Public Contract Code §7104(a) are encountered during prosecution of the Work, Contractor shall immediately, and before disturbing such conditions, notify VTA in writing of any:

- Material that Contractor believes may be material that is hazardous waste as defined in Section 25117 of the Health and Safety Code that is required to be removed to a Class I, II or III disposal site in accordance with the provisions of existing law.
- Subsurface or latent physical conditions at the site differing from those indicated by information about the site made available to Bidders prior to Bid Opening.
- Unknown physical conditions at the site of any unusual nature, different materially from those ordinarily encountered and generally recognized as inherent in work of the character provided for in this Contract.

VTA shall promptly investigate the conditions, and if it finds the conditions to be materially different or to involve hazardous waste, and cause a decrease or increase in Contractor's cost of, or the time required for, performance of any part of the Work, shall issue a change order under the procedures described in **Section 7.65 Change Requests and Change Notices** and **Section 7.66 Change Order**. Any suspension of Work shall be administered in accordance with the provisions of **Section 7.69 Suspension of the Work**. If a dispute arises between VTA and Contractor whether the conditions materially differ, or involve hazardous waste, or cause a decrease or increase in Contractor's cost of, or time required for, performance of any part of the Work, Contractor shall not be excused from any scheduled completion date provided for by this Contract, but shall proceed with all Work; *provided, however*, Contractor shall retain any and all rights provided either by contract or by law which pertain to the resolution of disputes and protests between the contracting parties.

**7.10. Reserved**

**7.11. Reserved**

**7.12. Patent Rights**

Any discovery or invention which is an integral part of the items being furnished under this Contract, as well as all information, design, specifications, data and findings which arise or is developed in the course of performing the Work under this Contract, shall become the property of VTA (and if federally funded, the property of FTA or FHWA).

**7.13. Intellectual Property, Copyright and Patent Infringement**

Contractor, upon VTA's request, shall defend VTA against any claim against VTA for patent, copyright, trademark, trade secret, or other intellectual property infringement based upon VTA's use of any work, goods, or services provided by Contractor pursuant to this Contract. If VTA requests Contractor to defend against such claim, Contractor shall hold VTA harmless from, and indemnify VTA for, any liability arising from the claim. This obligation shall not apply when the alleged infringement arises entirely from modification of the Work, goods, or services by VTA without Contractor's approval.

**7.14. Rights in Technical Data**

VTA shall have the right to use, duplicate or disclose, in whole or in part, in any manner and for any purpose whatsoever, and to have or permit others to use: (a) any manuals, instructional materials prepared for installation, operation, maintenance or training purposes and (b) technical data pertaining to end items, components or processes which were prepared for the purpose of identifying sources, size, configuration, mating and attachment characteristics, functional characteristics and performance requirements ("form, fit and function" data; e.g., specification control drawings, catalog sheets, outline drawing). The term Technical Data as used herein means technical writing, sound records, pictorial reproductions, drawings, or other graphic representations and works of a technical nature, whether or not copyrighted, which are specified to be delivered pursuant to this Contract. The term does not include financial reports, costs analyses, and other information incidental to contract administration.

For copyrighted material, Contractor agrees to and does hereby grant to VTA and the FTA (if applicable), and to their officers, agents and employees acting within the scope of their official duties, a royalty-free, nonexclusive and irrevocable license for VTA and FTA (if applicable) to publish, translate, reproduce, deliver, perform, dispose of, and to authorize others to use, all Technical Data now or hereafter covered by copyright.

No such copyrighted matter shall be included in Technical Data furnished hereunder without written notice of the copyright owner granting VTA and FTA (if applicable) consent to use such copyrighted matter in the manner above described.

Contractor shall report to VTA promptly and in reasonable written detail each notice or claim of copyright infringement received by Contractor with respect to any Technical Data delivered hereunder.

VTA reserves the right to use the design and the tooling developed for the furnishing of equipment under this Contract in future contracts based on this specification. Contractor shall maintain design data, including drawings, layouts, and any relevant engineering data, and all necessary tooling in good order for a minimum of four years after final acceptance of the last items furnished under this Contract, and shall



transfer that data, including tooling, to VTA upon request at no cost to VTA. All plans, drawings, diagrams, schematics, and specifications shall become the property of VTA and the FTA (if applicable), unless otherwise designated by VTA.

#### **7.15. Ownership of Work and Material**

VTA shall own all materials, work in progress, and finished goods produced by Contractor pursuant to this Contract, for which progress payments have been made and which have been satisfactorily delivered to a designated area. Such ownership shall be free of all encumbrances, or, if it is not, VTA may obtain a priority lien secured pursuant to appropriate sections of the Uniform Commercial Code and other applicable state laws or local ordinances to secure its title rights. Nevertheless, Contractor shall be responsible for risk of loss for those items of Work for which Contractor has care, custody and control, until Final Acceptance.

Unless otherwise specifically provided in this Contract, Contractor shall provide and pay for materials, equipment, tools, utilities, transportation, and other facilities and services (including all taxes thereon) necessary for the prosecution of the Work.

Contractor will submit to VTA a "Final Release of All Liens and Claims" as a condition precedent to receiving final payment under this Contract.

#### **7.16. Title and Risk of Loss**

Unless otherwise provided for, title to the Work and risk of loss shall pass to VTA upon final acceptance of the Work, and Contractor shall furnish or execute all necessary documents of title at that time.

#### **7.17. Assignment and Delegation**

Contractor shall not assign any of its rights or delegate any of its responsibilities under this Contract without the prior written consent of VTA.

#### **7.18. Subcontracts**

Contractor shall be fully responsible and liable for the products and actions of all subcontractors and suppliers of any tier, and shall include in each subcontract any provisions necessary to make all of the provisions of this Contract fully effective. Contractor shall provide all necessary plans, specifications, schedules, and instructions to its suppliers and subcontractors to enable them to properly perform their work. Contractor shall submit executed copies of all subcontracts entered into pursuant to this Contract to VTA within **7 calendar days** of such execution but no later than **15 calendar days** prior to the start of subcontractor's work.

In accordance with Public Contract Code Sections 4100 – 4114, **Subletting and Subcontracting Fair Practices Act**, Contractor shall not substitute any subcontractor listed on the Bid Forms or Contract Forms without the express written approval of VTA. Further, any substitution of any subcontractor shall be subject to the requirements of **Appendix C Business Diversity Policy and Requirements**.

#### **7.19. Waiver and Non-waiver**

A waiver by one party of a right to a remedy for breach of this Contract by the other party shall not be deemed to waive the right to a remedy for a subsequent breach by the other party. VTA's acceptance of

goods, services or payment under this Contract shall not preclude VTA from recovering against Contractor or Contractor's surety for damages due to Contractor's failure to comply with this Contract.

#### **7.20. Antitrust Claims**

In entering into a public works contract, or a subcontract to supply goods, services, or materials pursuant to a public works contract, Contractor agrees to assign to the awarding body all rights and title to, and all interest in all causes of action it may have under Section 4 of the Clayton Act, or under the Cartwright Act, arising from the purchases of goods, services, or materials pursuant to the public works contracts or subcontracts. This assignment shall be made and become effective at the time the awarding body tenders final payment to Contractor, without further acknowledgement by the parties.

#### **7.21. Stop Notices**

VTA will withhold payments otherwise due Contractor in order to satisfy Stop Notices which have been properly filed, in accordance with the requirements of California Civil Code Division 3, Part 4, Title 15, Chapter 4, regarding Stop Notices. Contractor shall include this **Section 7.21 Stop Notices** in all subcontracts and similar documents entered into by Contractor for the performance of Work under this Contract.

All Stop Notices, including Preliminary Notices, shall include a reference to the VTA contract number and the title of the Contract.

#### **7.22. Reserved**

#### **7.23. Reserved**

### AUTHORIZED REPRESENTATIVES AND COMMUNICATIONS

#### **7.24. Authorized Representatives**

Contractor shall designate, in writing, before starting any Work, an Authorized Representative who, during performance of the Contract, shall have full authority to act on Contractor's behalf in all matters within the scope of this Contract.

When Contractor is comprised of two or more persons, firms, partnerships, or corporations functioning on a joint venture basis, said Authorized Representative shall have the authority to represent and act for the joint venture.

Said Authorized Representative shall be present at the Worksite at all times while Work is actually in progress. When Work is not in progress and during periods when Work is suspended, arrangements acceptable to VTA shall be made for any emergency Work which may be required.

Whenever said Authorized Representative is not present on any particular part of the Work where VTA may desire to give direction, orders will be given by VTA, which shall be received and obeyed by the superintendent or foremen who may have charge of the particular Work in reference to which the orders are given.

Except as hereinafter provided, all orders by VTA shall be given in writing. Those not so given are invalid and not binding. Emergency conditions dealing with safety of persons and protection of property are

excepted and such oral directions will be confirmed in writing as soon as possible, but shall be immediately complied with by Contractor.

VTA will similarly designate, in writing, a VTA Authorized Representative to be its formal contact between VTA and Contractor. Said VTA Authorized Representative will be responsible for all matters relating to the execution of Work within the scope of this Contract and will decide all questions which may arise as to the quality or acceptability of the Work and as to the manner of performance and rate of progress of the Work; all questions which may arise as to the interpretation of plans and specifications; all questions as to the acceptable fulfillment of the Contract on the part of Contractor; and all questions as to compensation for Work performed.

Matters regarding the terms and conditions of this Contract shall be the responsibility of VTA's Procurement, Contracts and Materials Management Office.

Written notification to the other party shall be provided, in advance, of changes in the name or address or the scope of authority vested in such Authorized Representative.

Each Authorized Representative may, from time to time, delegate to other named individuals certain authority and responsibilities. The names of such individuals, the scope of their authority and responsibility, and the designation of their titles will be communicated to the other party in writing.

The designation of Authorized Representatives of the parties and their delegates as outlined above shall take place at the pre-construction meeting as specified in **Section 7.26 Pre-Construction Meeting**.

## **7.25. Notices and Communications**

### **7.25.1. Notices**

All notices and other communications concerning this Contract shall be written in English, shall bear the number assigned to this Contract by VTA and shall follow VTA's correspondence format and reference system. Notices and other communications may be delivered personally, by private package delivery, by regular, certified, or registered mail, or any electronic means acceptable to VTA.

The names of the individuals for each of the parties and their addresses to which other communications and correspondence should be delivered will be established and made known to the other party at the pre-construction meeting as specified in **Section 7.26 Pre-Construction Meeting**.

A notice to VTA will be effective only if it is delivered to VTA's Authorized Representative at the address to be made known to Contractor at the pre-construction meeting as specified in **Section 7.26 Pre-Construction Meeting**.

### **7.25.2. Drawing/Plan Clarification**

A drawing/plan clarification from VTA is intended to make some requirement(s) of the drawings or plans clearly understood. Drawing clarifications/plan clarifications may be sketches, drawings or in narrative form and shall not change any requirement of the Contract. Responses to Contractor inquiries shall be as outlined in **Section 7.25.3 Requests for Information (RFIs)**.

### **7.25.3. Requests for Information (RFIs)**

In the event Contractor, or any subcontractor or supplier, at any tier, determines that some portion of the drawings, specifications or other Contract Documents requires clarification or interpretation by VTA, Contractor shall submit a Request for Information (RFI) in writing to VTA. RFIs may be submitted only by

Contractor and shall only be submitted on the Request for Information form provided by VTA. Contractor shall clearly and concisely set forth the issue for which clarification or interpretation is sought and why a response is needed from VTA. In the Request for Information, Contractor shall set forth its own interpretation or understanding of the requirement along with the reasons why it has reached such an understanding.

VTA will review all RFIs to determine whether they are RFIs within the meaning of this Contract. If VTA determines that the document is not a RFI it will be returned to Contractor, unreviewed as to content, for resubmittal as the appropriate document required by the subject matter.

Responses to RFIs shall be issued within 5 working days of receipt of the request from Contractor unless VTA determines that a longer period of time is necessary to provide an adequate response. If a longer period of time is determined to be necessary, VTA will notify Contractor as soon as possible within those five (5) working days of the anticipated response time. The five (5) working days shall start at the time the RFI is received by VTA's designated contact person. If Contractor submits a RFI on an activity with five (5) working days or less of float on the current approved project schedule, Contractor shall mark the RFI as "Critical". Contractor shall not be entitled to any time extension due to the time it takes VTA to respond to such Critical request provided that VTA responds within the five (5) working days set forth above.

Responses from VTA will not change any requirement of the Contract Documents unless so noted in the response to the RFI. In the event Contractor believes that a response to a RFI will cause a change to the requirements of the Contract, Contractor shall immediately give written notice to VTA in accordance with **Section 7.65 Change Requests and Change Notices**. Failure to give such written notice shall waive Contractor's right to seek additional time or cost in accordance with **Section 7.65.1** of the Contract Documents.

## **7.26. Pre-Construction Meeting**

Prior to issuance of a Notice to Proceed, a pre-construction meeting will be held at a time and place to be designated by notice from VTA. At this meeting, detailed procedures will be discussed for handling the following items:

- Authorized Representative
- Correspondence
- Notices
- Change requests and change notices
- Change orders
- Submittals
- Approvals
- Progress payments
- Schedules
- Community relations
- Inspection plans
- Requests for information (RFI)
- Other pertinent agenda items

### **7.27. Project Meetings**

VTA will schedule and preside over all meetings (including, but not limited to, weekly, pre-production, periodic, and special meetings) throughout the progress of the Work. Agendas for the meetings may include, but are not necessarily limited to, discussions of performance observations, problems, conflicts, schedules, delivery schedules, supplier fabrication, quality standards, Contract modifications, and any other topics that VTA determines to be relevant to the project. Contractor attendance at these meetings is mandatory.

### **7.28. Publicity Releases**

All publicity releases or releases of reports, papers, articles, maps, or other documents in any way concerning this Contract or the Work hereunder which Contractor or any of its subcontractors desires to make shall be subject to approval by VTA prior to release.

### *TIME FOR PERFORMANCE OF WORK*

### **7.29. Notice to Proceed**

Contractor shall commence performance of Work under this Contract immediately after receipt of the Notice to Proceed issued by VTA, and shall continuously and diligently prosecute the Work to completion on or before the time or times set forth in **Section 6 Special Conditions** of this Contract. Any work performed or expenses incurred by Contractor prior to Contractor's receipt of Notice to Proceed shall be entirely at Contractor's risk.

Contractor will be required to give VTA a 48-hour advance notice before starting work. Contract personnel will be allowed on the job site only during normal VTA working hours unless otherwise authorized by VTA

### **7.30. Time of Completion**

Time is of the essence in this Contract. Contractor's failure to perform Work, deliver goods, or provide services on time and in accordance with the approved progress schedule shall be a material breach of this Contract.

Refer to **Section 6.22 References to Days** for definitions of days and recognized holidays.

Time periods measured in days will be computed by excluding the day upon which the period begins to run and including the last day of the period unless the last day is Saturday, Sunday, or a holiday, in which case the period shall run until, and shall include, the next day that is not a Saturday, Sunday, or holiday.

All time periods measured in days shall be based upon calendar days unless specified otherwise.

During actual construction, a calendar day shall not be a "working day" if Contractor is specifically required by the Contract Documents to suspend construction operations or if Contractor is prevented by inclement weather or otherwise, as determined by VTA and agreed to by Contractor, from proceeding with the Work as anticipated by the parties.

Contractor shall not perform any fieldwork during three annual designated holidays: Labor Day, Thanksgiving Day and Christmas Day. Fieldwork shall not include receipt or delivery of materials or equipment or work performed in field offices. During these periods, VTA will not have the construction management personnel to support, inspect, or oversee Contractor's Work.

### **7.31. Progress Schedule**

Contractor shall develop and maintain progress schedules in CPM format identifying critical events involved in the performance of the Work under the Contract in accordance with the requirements of **Section 6 Special Conditions**.

### **7.32. Excusable Delays and Extensions of Time**

Except with respect to defaults of Subcontractors, neither Contractor nor VTA shall be considered in default by reason of any failure to perform in accordance with the Contract schedule if such failure arises out of unexpected causes beyond the control and without the fault or negligence of the defaulting party. Such causes may include, but are not restricted to, acts of God or of the public enemy, acts of the government in its sovereign or contractual capacity, fires, floods, epidemics, quarantine restrictions, strikes or other labor disputes, freight embargoes, and unusually severe weather, but in every case the failure to perform must be beyond the control and without the fault or negligence of the defaulting party. If the failure to perform of either Contractor or VTA is caused by the default of a subcontractor or a third party Contractor to VTA, and if such default arises out of causes beyond the control of all the parties, and without the fault or negligence of any of them, neither Contractor nor VTA shall be in default by reason of any such failure to perform. As used herein, the terms "Subcontractor" and "Subcontractors" mean subcontractor(s) or supplier(s) to Contractor at any tier.

Should Contractor suffer delay because of cause(s) as described herein, VTA may, upon receiving Contractor's fully documented and supported written request timely made, make an equitable revision in the Contract schedule or other terms of the Contract as appropriate.

### **7.33. Failure to Complete the Work on Time**

If the Work is not completed by Contractor in the time specified, as that time may be extended as authorized elsewhere in the Contract, it is understood that VTA will suffer damage; and, it being impracticable and extremely difficult to determine the amount of actual damage, it is agreed that Contractor shall pay as fixed and liquidated damages, and not as a penalty, the sum set forth in **Section 6 Special Conditions** of the Contract for each calendar day of delay until the Work is completed and accepted, and Contractor and its surety shall be liable for the amount thereof.

## PERFORMANCE OF WORK

### **7.34. Contractor's Work Area**

Contractor shall be responsible for all security, utilities and upkeep of Work and laydown areas and for their restoration to a condition equal to that which existed when Contractor began using such areas. Such restoration shall be complete before final payment is made to Contractor. If VTA areas are not available to Contractor, Contractor shall be responsible for furnishing whatever areas it deems necessary to perform Work under this Contract, at no additional cost to VTA.

Contractor shall confine its equipment, storage of materials, and construction operations to such limits as may be directed by VTA and shall not unreasonably encumber the Worksite and roads with its materials and equipment. Contractor shall enforce the instructions of VTA regarding signs, advertising, fires, danger signals, barricades, and smoking, and shall require all persons employed on the Work to comply with all building or institutional regulations, vehicle, street and highway codes while on the premises and roads.

### **7.35. Temporary Construction Facilities and Utilities**

Contractor shall furnish all temporary construction facilities, utilities, and services which are necessary to prosecute the Work. This includes, but is not limited to fencing, flagmen, sanitary facilities, security, power, water, and weather protection. Contractor shall remove all temporary facilities upon completion of the Work or when they are no longer needed for Contractor's purposes, whichever is earlier.

### **7.36. Character of Workers**

If any Subcontractor or person employed by Contractor shall appear to VTA to be incompetent or to act in a disorderly, improper or unsafe manner, such person shall be discharged immediately on the request of VTA, and such person shall not again be employed on the Work.

### **7.37. Working Environment**

Contractor shall ensure and maintain a working environment free of personal harassment and intimidation between Contractor's forces and VTA employees and members of the public at all VTA project sites and in all VTA facilities at which Contractor's forces are assigned to work. Conduct that creates an intimidating, hostile, or offensive working environment is prohibited. Failure to comply with the above will be considered a material breach of this Contract.

### **7.38. Public Convenience and Safety**

Contractor shall so conduct its operations as to offer the least possible obstruction and inconvenience to the public and shall have under construction no greater length or amount of work than can be prosecuted properly with due regard to the rights of the public. Unless otherwise provided in the Contract, all public traffic shall be permitted to pass through the Work with as little inconvenience or delay as possible. Where possible, such traffic shall be routed on new or existing paved surfaces. Spillage resulting from hauling operations along or across any public traveled way shall be removed immediately by Contractor at its expense. Existing traffic signal and highway lighting systems shall be kept in operation for the benefit of the traveling public during progress of the Work, and other forces will continue routine maintenance of existing systems.

Contractor shall install signs, lights, flares, barricades, and other facilities for the sole convenience and direction of public traffic and shall furnish competent flaggers or a uniformed police officer whose sole duties shall consist of directing the movement of public traffic through or around the Work.

Work shall be performed in such a manner as to eliminate unnecessary noise, obstructions and other annoyances to occupants. Contractor will not encumber premises with materials, equipment, and/or parking of cars; Contractor shall store materials, equipment and park cars in designated areas.

See **Section 8 Technical Specifications** for additional traffic control requirements, if any.

### **7.39. Cooperation/Coordination and Work by Others**

Contractor shall coordinate its Work with all other contractors and subcontractors performing Work on the site. Contractor shall schedule its Work so as to avoid conflicts with other contractors and to avoid damage to completed or incomplete Work. Contractor shall be responsible for any damage to the Work of other contractors or subcontractors if Contractor's actions resulted in such damage and are a) willful or b) negligent and the proximate cause. Contractor shall take immediate action to remedy such damage so as to not delay the immediate prosecution of the Work.

#### **7.40. Security**

Contractor shall provide and be responsible for all security at the Worksite which is required to protect its material and equipment and all Work in place. Contractor shall also be responsible for providing all security and traffic control required by any city having jurisdiction in the area where Work is being performed.

#### **7.41. Product Options, Supplier Approval and Substitutions**

For products specified in this Contract or in Contractor's submittals by brand name or manufacturer, whether or not followed by the words "or approved equal," Contractor shall select any product or manufacturer named, or shall submit a request to substitute an equal product or manufacturer. As required by the California Public Contracts Code §3400, such request shall be made within **35 calendar days** from date of the Notice of Award in order to receive consideration, unless later submission of a request is agreed to by VTA. Contractor shall submit a separate request for each substitution. The burden of proof as to the equality of any material, process or article shall rest with Contractor. VTA's determination of the equality or superiority of an article proposed for substitution shall be based upon but need not be limited to consideration of such factors as are specified in the Technical Specifications; dimensional compatibility with other materials with which it combines to produce a unified design system; all aspects of finished appearance including form, texture, and color, as it affects other design elements. In the event an approved substitution is more expensive than the specified materials, process or article, the difference in cost of such material, process or article so furnished shall be borne by Contractor. Contractor may not make a substitution without VTA's prior written approval. If applicable, specific requirements for the submittal of such requests will be contained in **Section 6 Special Conditions**.

VTA shall approve or disapprove Contractor's request for substitution of suppliers or products within 30 days of VTA's receipt of all information required by VTA for such determination.

#### **7.42. Source of Materials**

Contractor shall be completely responsible for locating, identifying, and furnishing all materials required to be furnished under this Contract, except for VTA furnished materials specified in **Section 6 Special Conditions**. VTA shall perform or cause to be performed all tests required to demonstrate to VTA's satisfaction that the proposed materials satisfy the requirements of the Contract

#### **7.43. Submittal of Shop Drawings, Product Data and Samples**

Working and shop drawings may consist of drawings, diagrams, schedules, or other data prepared by Contractor, or any subcontractor of any tier, manufacturer, supplier or distributor, as are necessary to adequately control the Work or to illustrate or detail some portion of the Work. No change shall be made by Contractor in any working or shop drawing after it has been approved by VTA.

Working Drawings for any part of the permanent Work shall include, but not be limited to: stress sheets, anchor bolt layouts, shop details, erection plans, equipment lists and any other information specifically required elsewhere in the Contract.

Working drawings for cribs, cofferdams, falsework, temporary support systems, haul bridges, centering and form work and for other temporary work and methods of construction Contractor proposes to use, shall be submitted when required by the Contract or ordered by VTA.



Product data are illustrations, standard schedules, performance charts, instructions, brochures, diagrams, or other information furnished by Contractor to illustrate materials, products, systems, or equipment for some portion of the Work.

Samples are physical examples that illustrate materials, equipment, or workmanship, and establish standards by which the Work shall be judged.

Working drawings and shop drawings, product data, samples, and similar submittals shall not modify any Contract requirement, except as expressly allowed by this Contract. The purpose of their submittal is to demonstrate, for those portions of the Work for which submittals are required, the way Contractor proposes to comply with Contract requirements.

Contractor shall review, approve, and submit to VTA all working and shop drawings, product data, samples, or similar submittals required by this Contract, or that are necessary for its proper completion, in accordance with the Schedule for Technical Submittals shown in **Section 6 Special Conditions** and **Section 8 Technical Specifications**, in a sequence that causes no delay in the Work, or in the work of VTA or any other VTA Contractor.

By approving and submitting working and shop drawings, alternative construction methods, product data, samples, or similar submittals, Contractor represents that it has determined and verified all related materials, measurements, and construction criteria, and that it has checked and coordinated the information contained within its submittals with the requirements of the Work and this Contract.

Contractor shall not be relieved of responsibility for any deviation from the requirements of this Contract by VTA's approval of shop and working drawings, product data, samples, plans, programs, schedules, or similar submittals unless Contractor has specifically informed VTA at the time of submittal in writing of the deviation and VTA has given written approval of the specific deviation. Contractor shall not be relieved of responsibility for errors or omissions in working and shop drawings, product data, samples, plans, programs, schedules or similar submittals by VTA's approval of the submittal. Contractor shall not deviate from approved working and shop drawings, product data, samples, or similar submittals without VTA's written approval.

Contractor shall not commence any portion of the Work requiring submission of shop or working drawings, product data, samples, or similar submittals until the required submittal has been approved by VTA.

Contractor shall direct specific attention, in writing or on resubmitted shop and working drawings, product data, samples, or similar submittals, to revisions other than those required by VTA on previous submittals.

Specific requirements for the submittal of shop and working drawings, product data and samples are contained in **Section 6 Special Conditions**.

Full compensation for furnishing all working and shop drawings, product data and samples is included in the prices paid for the Contract Items of Work (as defined in **Section 7.56 Compensation**) to which such drawings relate and no additional compensation will be allowed.

## **7.44. Survey Requirements**

### **7.44.1. Lines and Grades.**

Surveying is to be provided as follows:

- (a) VTA will provide primary control monuments for the project. Horizontal and vertical datums will be provided to Contractor.
- (b) Contractor must independently verify the primary horizontal and vertical control and inform VTA of any significant differences between published values and found values.
- (c) Contractor will use said primary control to set such stakes or marks as it determines necessary to establish the line and grades required for the performance of the Work specified in the Contract. Relevant right of way data will be supplied by VTA to Contractor. Contractor is responsible for all construction staking on project.
- (d) Contractor shall notify VTA of any conflicts between design and existing conditions and submit a Request for Information (RFI) before commencing survey.
- (e) Contractor will provide systematic and organized copies of all field notes and cut sheets to VTA on a weekly basis (documents must be delivered at least 24 hours before VTA verification survey is scheduled). Name of firm, job description, party chief, crew members, and date of survey shall appear on all field notes and cut sheets.

VTA Survey will perform periodic verification surveys to quality assure construction staking effort. VTA verification surveys may be performed at any time.

#### **7.44.2. Monument Preservation**

For the purposes of this **Section 7.44.2** the word Contractor refers to the General Contractor assigned to VTA's project and the professional surveyors under the employ of said General Contractor.

Contractor shall notify VTA of any existing monuments which will be disturbed or destroyed during the course of construction and Contractor will be responsible – and bear the full costs - for tying out the existing monuments and setting new monuments, per the Professional Land Surveyors' Act, Business and Professional Code Sections 8771 through 8773.

Contractor shall place new monuments (when possible) in a location to minimize traffic exposures for surveyors. Existing monuments to be replaced by the new monuments shall be removed and disposed of by Contractor. New monuments shall be established before existing monuments are removed so that vertical and horizontal control shall be available at all times. The following guidelines will be used as part of the monument preservation process:

- (a) **Pertaining to existing, undisturbed monuments:** Contractor will reset the monument box (with cover) to final grade. If there is no monument box for the monument then Contractor will set a new one at grade to preserve the monument and to make it accessible. If the monument is higher than final grade then Contractor's professional land surveyor will set ties to the monument and reset it below final grade and set the monument box accordingly.
- (b) **Pertaining to destroyed or disturbed monuments:** Contractor must notify VTA Survey, in advance, of any monuments that will be disturbed and/or destroyed.
  - (1) Contractor will replace all monuments that VTA's Survey Department determines are of future value to professional surveyors in retracing original surveys of record and will be set according to VTA specifications. Contractor may be asked by VTA to also contact the City Engineering/Survey Department or other agency/s (e.g., County, Caltrans, Santa Clara

Valley Water District, etc.) for additional information regarding monument and monument box specifications.

- (2) Monuments shall be constructed in accordance with the appropriate City or other agency's Standard Provisions, to the dimensions and details shown on the appropriate City or other agency's Standard Details.
- (3) Any monument that Contractor cannot replace in its original position due to obstruction or improvements must be replaced with a witness monument that is tied into the original monument by bearing and distance.
- (4) Contractor will then establish project coordinates for all new monuments and witness monuments, adjust by least squares method and furnish VTA Survey with the results and the calculation sheets.

Note: These standards are VTA standards and Contractor is not only bound by these standards but also the most recent update of the State Land Surveyors Act and the standards currently established by the appropriate City or other agency (e.g., County, Caltrans, Santa Clara Valley Water District, etc.). VTA and the appropriate City or other agency must be allowed to review all Corner Records and/or relevant documentation before Contractor's first submittal to the County Surveyor.

**Contractor will bear the full expense of all work related to the above described monument preservation program. If the above specified "advance" notice is not given to the VTA Survey Department and/or the survey monuments are disturbed or destroyed without reference points having been set, VTA will re-establish the original position of the survey monuments (and all necessary tie monuments) and the associated land surveying costs will be deducted from Contractor's budget amount.**

#### **7.45. Protection and Restoration of Property**

In addition to any other requirements imposed by law, Contractor shall shore up, brace, underpin, and protect as may be necessary, all foundations and other parts of all existing structures adjacent to and adjoining the Worksite which are in any way affected by Contractor's operations. Whenever any notice is required to be given by VTA or Contractor to any adjoining or adjacent landowner or other party before beginning any Work under this Contract, such notice shall be given by Contractor.

Any damage arising from or in consequence of the performance of the Contract, to improvements or property, whether above or below ground, private or public, within or adjacent to the project limits, shall be repaired at once by Contractor. If the best interests of VTA requires such repair to be made prior to the execution of any part of the Work included in this Contract, VTA will so notify Contractor who shall delay or discontinue the performance of that part of the Work until the necessary repair has been made. Such delay shall not be considered unavoidable, and no extension of time for completion of the Contract will be made.

When ordered by VTA to make any such repair, Contractor shall start work thereon within four hours and shall prosecute the same with diligence to completion. Upon failure of Contractor to so comply with such order, or upon Contractor's failure to make immediate emergency repairs which are necessary in the best interests of VTA or of the Public, VTA shall have the authority to cause such repair to be made and to deduct the costs thereof from any money due, or which may become due Contractor.

In any emergency affecting the safety of life or property including adjoining property, Contractor, without special instructions or authorization from VTA, is authorized to act at Contractor's discretion to prevent such threatened loss or injury, and Contractor shall so act whether or not it is instructed to do so by VTA.

#### **7.46. Utility Paint Markings**

Contractor shall completely remove all utility paint markings at project completion. Removal will be by use of the high water pressure method only. Payment for removal of all utility paint markings is included in the price paid for other items of work and no additional compensation will be allowed for this work.

#### **7.47. Reserved**

#### **7.48. Inspection**

VTA shall at all times have access to the Work during construction and shall be furnished every reasonable facility for verifying that the materials and workmanship conform to the requirements of the Contract. All work done and all materials furnished shall be subject to VTA's on-site and off-site inspection and approval. VTA may test and inspect, either at Contractor's, subcontractor's or supplier's facility, all components, subsystems or workmanship prior to assembly of such components into the Work and prior to acceptance of the Work by VTA. Following such testing and inspection, VTA will issue a deficiency list to Contractor listing those items which fail to comply with the Contract. VTA may either reject or require correction of defective material, workmanship, or nonconformity to this Contract. Contractor shall, at its own expense, make available tools, pits, hoists, scaffolds, platforms, other equipment, facilities, drawings, and assistance as may be necessary for inspections or tests.

Costs of the inspectors shall be borne by VTA and shall not be a part of the Contract Price. Costs of re-inspection shall be backcharged to Contractor. The performance of, or the failure to perform, such inspection shall not relieve Contractor of any responsibility for complete Contract performance. Where shop inspection is required by the terms of the Contract, Contractor shall not ship materials until VTA releases such materials for shipment.

Contractor shall not cover any work until inspected and released by VTA. Re-examination of covered and questioned work may be ordered by the Authorized Representative at any time prior to final acceptance. If so ordered, the work shall be uncovered by Contractor. The testing and uncovering or removal, replacement and recovering shall be at Contractor's expense.

#### **7.49. Certificates of Compliance and Testing**

##### **7.49.1. Certificates of Compliance**

When so authorized in the Contract or when permitted by VTA, the use of certain materials or assemblies shall be allowed if accompanied by a Certificate of Compliance. VTA reserves the right to refuse to permit the use of material on the basis of a Certificate of Compliance. If such use is permitted, the form of the Certificate of Compliance and its disposition shall be as directed by VTA. The certificate shall be signed by the manufacturer of the material or the manufacturer of assembled materials and shall be furnished with each lot of material delivered to the Work and the lot so certified must be clearly identified in the Certificate.

All materials used on the basis of a Certificate of Compliance may be sampled and tested by VTA at any time. The fact that material is used on the basis of a Certificate of Compliance shall not relieve Contractor

of responsibility for incorporating material in the Work which conforms to the requirements of the Contract and any such material not conforming to such requirements will be subject to rejection whether in place or not.

#### **7.49.2. Testing**

Contractor shall obtain the services of an independent testing company to perform all testing of materials and work in accordance with the Contract Documents. All material testing shall be paid for by Contractor.

**VTA may, at its discretion, perform or cause to be performed test of materials and work independent of Contractor's responsibility above.** When VTA exercises its discretion, Contractor shall furnish without cost adequate samples of all materials necessary for testing, and shall also designate the source of such material where appropriate

#### **7.49.3. Furnish without Charge**

When requested by VTA, Contractor shall furnish, without charge, samples of all materials entering into the Work, and no material shall be used prior to approval by VTA, except as provided in this **Section 7.49 Certificates of Compliance and Testing**. Samples of material from local sources shall be taken by or in the presence of VTA, otherwise the samples will not be considered for testing.

#### **7.50. Removal of Rejected or Unauthorized Work**

All work which has been rejected shall be remedied, or removed and replaced by Contractor in a manner acceptable to VTA, and no compensation will be made for such removal, replacement or remedial work.

Any work performed outside of the limits of Work shown on the drawings or established by VTA, or any extra work done without written authorization of VTA will not be paid for. Upon order of VTA such unauthorized work shall be remedied, removed or replaced at Contractor's expense.

If Contractor fails to comply within a period of seven days (or such longer period as VTA may authorize in writing) after receipt of notice from VTA specifying such failure, VTA may cause the rejected or unauthorized work to be removed, replaced, or remedied, and to deduct the costs thereof from any moneys due to Contractor.

#### **7.51. Disposal of Materials**

Except for materials generated pursuant to **Section 7.9 Hazardous Materials or Unusual Conditions**, Contractor shall be responsible for the disposal of all excess materials generated during the performance of this Contract. When any material is to be disposed of outside the project area, other than a public dump, Contractor shall first obtain a written permit from the property owner on whose property the disposal is to be made and he shall file with VTA said permit or a certified copy thereof together with a written release from the property owner absolving VTA from any and all responsibility in connection with the disposal of material and said property, and before any material is disposed of on said property, Contractor shall obtain written permission from VTA to dispose of the material at the location designated in said permit.

#### **7.52. Protection of Completed Portions of Work**

Contractor shall protect completed portions of the Work until final acceptance of the Work by VTA. Contractor shall take prompt action to remedy or repair any and all damage sustained to Work that is partially or wholly complete and has not yet been accepted by VTA.

### **7.53. Clean-up**

In addition to any requirements which may be included in **Section 8 Technical Specifications**, Contractor shall at all times during performance of Work under this Contract, keep the site clean from all rubbish and debris. Before final inspection of the Work, Contractor shall clean the material sites and all ground occupied by it in connection with the Work of all rubbish, excess materials, falsework, forms, temporary structures, and equipment. All parts of the Work shall be left in a neat and presentable condition.

### **7.54. Redlined Construction Drawings**

Drawings showing all approved changes made during construction which differ from the approved drawing set for construction, shall be furnished by Contractor prior to the acceptance of the Work. Final construction drawings submitted to VTA shall be in the form of redlined drawings clearly and neatly indicating all changes made with the approval of VTA and other field changes made which reflect the as-built condition of the Contract. During the construction period, redlined construction drawings shall be maintained by Contractor and made available to VTA for review on a daily basis.

### **7.55. Final Inspection and Acceptance of All or a Portion of the Work**

#### **7.55.1. Final Inspection and Acceptance of all the Work**

When Contractor considers that all of the Work covered under this Contract has reached final completion, Contractor shall so inform VTA in writing. If necessary and required, acceptance tests on the Work will be performed as set forth in **Section 8 Technical Specifications**. VTA will prepare a punchlist covering the Work that fails to pass the acceptance tests or is otherwise unacceptable and will reject such Work. Contractor shall proceed immediately to correct or replace unsatisfactory, incomplete or unacceptable work. For items of Work not completed by Contractor VTA may proceed to have the items corrected or completed using VTA or third party forces in accordance with **Section 7.50 Removal of Rejected or Unauthorized Work**. The costs of such corrections shall be deducted from compensation due Contractor.

Unless otherwise stipulated, title to such rejected Work and risk of loss shall remain with Contractor, and Contractor shall have the responsibility and bear all costs to correct all defects or damage. All acceptance testing of Work which has been rejected previously shall be at Contractor's expense and costs incurred by VTA to perform such re-tests shall be deducted and withheld by VTA from payments otherwise due to Contractor.

Final acceptance of all of the Work deemed complete will occur after successful completion of all testing and deficiency and punchlist items, and VTA's determination that the Work conforms in all respects to all the Contract requirements. VTA shall inform Contractor of such acceptance of the Work by issuing a written notification stating that the Work has been completed in accordance with the Contract requirements and is accepted under the terms and conditions thereof. After VTA has formally accepted the Work, Contractor will be relieved of the duty of maintaining and protecting the accepted Work and will not be required to perform any further Work thereon; and Contractor shall be relieved of its responsibility for injury to persons or property or damage to the Work which occurs after formal acceptance by VTA. Acceptance of the Work shall not relieve Contractor from responsibility for errors, improper fabrication, non-conformance to a Contract requirement, latent defects, or for deficiencies within Contractor's control. Unless otherwise stipulated, all warranties begin with the date of such acceptance of all of the Work. Coincident with such acceptance, VTA may record a Notice of Completion.

### **7.55.2. Final Inspection and Acceptance of a Portion of the Work**

VTA may at its discretion accept a discrete portion of the Work covered under this contract. When VTA considers that a discrete portion of the Work covered under this Contract has reached final completion, VTA shall inform Contractor in writing. If necessary and required, acceptance tests on the discrete portion of Work will be performed as set forth in **Section 8.0 - Technical Specifications**. VTA will prepare a punchlist covering any part of the discrete portion of Work that fails to pass the acceptance tests or is otherwise unacceptable and will reject such Work. Contractor shall proceed immediately to correct or replace unsatisfactory, incomplete or unacceptable Work. For items of Work not completed by Contractor VTA may proceed to have the items corrected or completed using VTA or third party forces in accordance with **Section 7.50 Removal of Rejected or Unauthorized Work**. The costs of such corrections shall be deducted from compensation due Contractor.

Unless otherwise stipulated, title to such rejected Work and risk of loss shall remain with Contractor, and Contractor shall have the responsibility and bear all costs to correct all defects or damage. All acceptance testing of Work which has been rejected previously shall be at Contractor's expense and costs incurred by VTA to perform such re-tests shall be deducted and withheld by VTA from payments otherwise due to Contractor.

Final acceptance of a discrete portion of Work deemed complete will occur after successful completion of all testing and deficiency and punchlist items, and VTA's determination that the Work conforms in all respects to all the Contract requirements. VTA shall inform Contractor of such acceptance of the Work by issuing a written notification stating that the Work has been completed in accordance with the Contract requirements and is accepted under the terms and conditions thereof. After VTA has accepted the Work, Contractor will be relieved of the duty of maintaining and protecting the accepted Work and will not be required to perform any further Work thereon and Contractor shall be relieved of its responsibility for injury to persons or property or damage to the Work which occurs after formal acceptance by VTA. Acceptance of a discrete portion of the Work shall not relieve Contractor from responsibility for errors, improper fabrication, non-conformance to a Contract requirement, latent defects, or for deficiencies within Contractor's control. Unless otherwise stipulated, all warranties begin with the date of such acceptance of the particular discrete portion of the Work.

### COMPENSATION, PAYMENTS, RECORDS AND AUDIT

#### **7.56. Compensation**

Contractor accepts the compensation set out in the Contract as full payment for satisfactorily completing all the Work.

Neither the payment of any progress payment nor any retained percentage shall relieve Contractor of any obligation to make good any defective work or material.

No compensation will be made in any case for the loss of anticipated profits.

Should the total performed quantity of any item of Work required under the contract exceed the quantity in the **Schedule of Quantities and Prices** by more than 25 percent, the Work in excess of 125 percent of the quantity in the **Schedule of Quantities and Prices** and not covered by an executed contract change order specifying the compensation to be paid therefore will be paid for by adjusting the contract unit price, as hereinafter provided, or at the option of VTA payment for the Work involved in the excess will be made on the basis of force account as provided in **Section 7.60 Force Account Payment**.

The adjustment of the contract unit price will be the difference between the contract unit price and the actual unit cost, which will be determined as hereinafter provided, of the total performed quantity of the item. If the costs applicable to the item of Work included fixed costs, the fixed costs will be deemed to have been recovered by Contractor by the payments made for 125 percent of the quantity in the **Schedule of Quantities and Prices** and in computing the actual unit cost; the fixed costs will be excluded. Subject to the above provisions, the actual unit cost will be determined by VTA in the same manner as if the Work were to be paid for on force account basis as provided in in **Section 7.60 Force Account Payment**; or the adjustment will be as agreed to by Contractor and VTA.

When the compensation payable for the number of units of an item of Work performed in excess of 125 percent of the quantity in the **Schedule of Quantities and Prices** is less than \$5,000.00 at the applicable contract unit price, VTA reserves the right to make no adjustment in the contract unit price if VTA so elects, except that an adjustment will be made if requested in writing by Contractor.

### **7.57. Increased or Decreased Quantities and Quantity Variation**

Increases or decreases in the quantity of a Contract unit price in the Schedule of Quantities and Prices ("**Contract Item**") will be determined by comparing the total performed quantity of that item of Work with the quantity in the **Schedule of Quantities and Prices**.

If the total performed quantity of a Contract Item required under the Contract varies from the quantity in the **Schedule of Quantities and Prices** by 25 percent or less, payment will be made for the performed quantity of that item of Work at the Contract unit price.

Should the total performed quantity of any item of Work required under the Contract be less than 75 percent of the quantity in the **Schedule of Quantities and Prices**, an adjustment in compensation pursuant to this Section will not be made unless Contractor so requests in writing. If Contractor so requests, the quantity of the Contract Item, unless covered by an executed contract change order specifying the compensation payable therefore, will be paid for by adjusting the Contract unit price as hereinafter provided, or at the option of VTA, payment for the performed quantity of that the Contract Item will be made on the basis of force account as provided in in **Section 7.60 Force Account Payment**, provided however, that in no case shall the payment for that Work be less than that which would be made at the Contract unit price.

The adjustment of the Contract unit price will be determined as hereinafter provided, of the total performed quantity of the item, including fixed costs. The actual unit cost will be determined by VTA in the same manner as if the Work were to be paid for on a force account basis as provided in in **Section 7.60 Force Account Payment** or the adjustment will be as agreed to by Contractor and VTA.

The payment for the total performed quantity of the item of Work will in no case exceed the payment, which would be made for the performance of 75 percent of the quantity in the **Schedule of Quantities and Prices** for the item at the original Contract unit price

If the total performed quantity of any item of Work required under the Contract varies from the quantity in the **Schedule of Quantities and Prices** by more than 25 percent, in the absence of any executed contract change order specifying the compensation to be paid, the compensation payable to Contractor will be determined in accordance with **this Section 7.57**.

Should the total performed quantity of any item of Work required under the Contract exceed the quantity in the **Schedule of Quantities and Prices** by more than 25 percent, the Work in excess of 125 percent of the quantity in the **Schedule of Quantities and Prices** and not covered by an executed contract change



order specifying the compensation to be paid therefore will be paid for by adjusting the Contract unit price, as hereinafter provided, or at the option of VTA payment for the Work involved in the excess will be made on the basis of force account as provided in **Section 7.60 Force Account Payment**.

The adjustment of the Contract unit price will be the difference between the Contract unit price and the actual unit cost, which will be determined as hereinafter provided, of the total performed quantity of the item. If the costs applicable to the item of Work included fixed costs, the fixed costs will be deemed to have been recovered by Contractor by the payments made for 125 percent of the quantity in the **Schedule of Quantities and Prices** and in computing the actual unit cost; the fixed costs will be excluded. Subject to the above provisions, the actual unit cost will be determined by VTA in the same manner as if the Work were to be paid for on force account basis as provided in **Section 7.60 Force Account Payment**; or the adjustment will be as agreed to by Contractor and VTA.

When the compensation payable for the number of units of an item of Work performed in excess of 125 percent of the quantity in the **Schedule of Quantities and Prices** is less than \$5,000.00 at the applicable contract unit price, VTA reserves the right to make no adjustment in the Contract unit price if VTA so elects, except that an adjustment will be made if requested in writing by Contractor.

## **7.58. Certified Payrolls**

### **7.58.1. Submit Certified Copies**

Contractor shall submit weekly for each week in which any Contract Work is performed a certified copy of all payrolls for its employees and a certified copy of all of its subcontractor's payrolls directly to the California State Labor Commissioner, Department of Industrial Relations and VTA within one week following the week when work was performed. The payrolls shall conform to the requirements of the **California Labor Code Section 1776** and shall be in a form acceptable to VTA. This project is subject to compliance monitoring and enforcement by the Department of Industrial Relations.

### **7.58.2. Form of Certified Copies**

Unless otherwise specified in **Section 6 Special Conditions**, Contractor and all lower-tier subcontractors and suppliers (if performing covered work) shall be required to submit certified payrolls and labor compliance documentation electronically.

Electronic submittal will be a web-based system, accessed on the internet at the address(es) provided by VTA. The web based system is LCPtracker. Contractor and each subcontractor will be given a Log On identification and password to access the reporting system. Contractor is responsible for managing and certifying all lower tier subcontractors certified payroll submittals.

Use of the system requires data entry of weekly payroll information including; employee identification, labor classification, total hours worked and hours worked on this project, wage and benefit rates paid, and Apprenticeship Certifications. Additionally, documents such as Apprenticeship Certifications, etc., will be electronically uploaded into the system.

Contractor will incorporate into every lower-tier subcontract and purchase order these instructions where labor compliance documentation is required.

In the event of a failure of the web based electronic system, Contractor shall be required to submit paper copies of certified payrolls and other required labor compliance documents.

Upon written request of Contractor, and at the sole discretion of VTA, any subcontractor may be permitted to submit paper copies of certified payrolls and other required labor compliance documentation in lieu of electronic copies.

## **7.59. Progress Payment**

### **7.59.1. Schedule of Values**

#### **(1) For Contracts $\geq$ \$500,000**

Following Notice of Award and 15 days prior to the first invoice submittal Contractor shall prepare and submit for approval a detailed cost breakdown of all Lump Sum Items, setting forth the estimated value of the various elements of work in conformity with the organization indicated in the Initial 90 Day and Baseline Schedules. Each item in the Schedule of Values shall include its proper share of overhead and profit. A proposed Schedule of Values may be rejected if any item is determined by VTA to be unbalanced or VTA deems it to be incomplete. VTA may request a detailed cost breakdown of any items. This breakdown shall be for the purpose of enabling Contractor and VTA to check and verify the periodic invoices to be submitted by Contractor in connection with requests for partial payments as provided for below.

The Schedule of Values breakdown will also be used in the calculation of changes whether additive or deductive, to work performed under Lump Sum Bid Items, to the extent applicable.

#### **(2) For Contracts $<$ \$500,000**

If the Contract is bid on a Lump Sum basis, or there are Lump Sum line items in the Schedule of Quantities and Prices, within 10 working days following Notice of Award, Contractor shall prepare and submit a detailed Schedule of Values giving a complete breakdown of all Lump Sum prices, setting forth the estimated value of the various subdivisions of the work. Each item in the Schedule of Values shall include its proportionate share of overhead and profit. A proposed Schedule of Values may be rejected if any item is determined by VTA to be unbalanced or VTA deems it to be incomplete. VTA may request a detailed cost breakdown of any items. The Schedule of Values shall be for the purpose of enabling Contractor and VTA to agree upon progress payment documents as described below. Notice to Proceed shall not be given until the Schedule of Values is approved by VTA.

### **7.59.2. Progress Payment Processing**

Once every thirty days during the term of the Contract, Contractor will prepare estimates of the work performed and materials delivered. Contractor will submit the estimates to VTA on Contractor-supplied letterhead for review. VTA will review and verify whether all items, units, quantities and prices shown on the Contractor-provided invoice are correct and that all work has been performed and materials supplied in accordance with the terms of the Contract.

If VTA is not in agreement with the quantities/prices on Contractor's invoice, VTA will schedule a meeting to review the discrepancies after which Contractor will submit a revised invoice. No payment will be due on the disputed amounts.

Upon verification and acceptance, VTA will prepare a "Progress Payment – Form B" that includes all the agreed units, quantities and prices. VTA will sign the Form B and forward the signed copy to Contractor for counter-signature and inclusion of the revised invoice for onward transmission to VTA Accounts

Payable. The invoice Contractor transmits for payment must match the amount due shown on the Form B less retention and any special withholdings.

As a condition precedent to any progress payment becoming due, Contractor must include along with each invoice:

- (a) conditional waivers and releases of lien, stop payment notice, and payment bond rights every subcontractor or supplier has with respect to all labor, services, materials, and equipment covered by the invoice; and
- (b) unconditional waivers and releases of lien, stop payment notice, and payment bond rights every subcontractor or supplier has with respect to labor, services, materials, and equipment covered by the previous invoice.

Payment to Contractor will be made 30 days following receipt of Contractor's invoice in VTA's Accounts Payable department. However, no payment shall be due until Contractor returns the certified Form B, the required waivers and releases, and the accompanying invoice to VTA.

### **7.59.3. Full Compensation**

Payment for various bid items listed in the Schedule of Quantities and Prices (Bid Form 1) shall constitute full compensation to complete the Work in conformity with the Contract. All costs for Work shown or indicated in the Contract Documents, even if not specifically provided for by a bid item in the Schedule of Quantities and Prices shall be included. Except for relief provided by **Section 7.65 Change Requests and Change Notices**, **Section 7.66 Change Order**, and **Section 7.67 Differing Site Conditions**, Contractor will not be entitled to additional compensation for providing any activity or material necessary for the completion of the Work in accordance with the Contract even though the activity or material is not included in a specific bid item or indicated in the Contract.

### **7.59.4. Materials on Hand**

Acceptable materials on hand consist of materials or equipment furnished and delivered by Contractor to its facility or the jobsite but not yet incorporated in the Work, and properly stored in a location acceptable to VTA.

In order for materials on hand to be approved for payment, Contractor shall request payment for them on VTA-furnished forms accompanied by documentation as therein required including evidence of purchase, if appropriate. The materials must be separated from other like materials and must be physically identified as the property of VTA for use only on this Contract. VTA may enter upon the premises of Contractor for the purpose of inspection, checking or auditing, or for any other purpose, as VTA considers necessary.

### **7.59.5. Retention**

VTA will retain **five percent** of each progress payment as part security for the fulfillment of the Contract by Contractor, and shall pay to Contractor the balance not retained, after deducting all previous payments and all sums to be kept or retained under the provisions of the Contract. No such payment will be construed to be an acceptance of any defective Work or improper materials.

Should the Contract Amount be subsequently modified by change order(s), VTA will hold retention on payments for the additional change order Work.

**If Federal requirements apply (refer to Section 1.8), then the following applies:** In conformance with **Public Contract Code Section 7200(b)**, in subcontracts between Contractor and subcontractor and in subcontracts between subcontractor and any subcontractor thereunder, retention proceeds shall not be withheld, and the exceptions provided in **Public Contract Code Section 7200 (c)** shall not apply. At the option of Contractor, subcontractors shall be required to furnish payment and performance bonds issued by an admitted surety.

#### **7.59.6. Special Withholding**

VTA may withhold amounts from any payments otherwise due to Contractor as it determines necessary to cover:

- (a) Claims against Contractor arising from or in any way related to this Contract, any other contract between VTA and Contractor, or any other transaction or occurrence involving VTA and Contractor;
- (b) Defective work not remedied;
- (c) Failure of Contractor to make proper payments to any of its Subcontractors;
- (d) Failure to complete the Work in accordance with the approved Contract progress schedule.
- (e) Damage to other work or property caused by Contractor or its subcontractor of any tier.
- (f) An amount, not less than ten percent (10%) of the total progress payment, due to the failure to abate, within one (1) working day or immediately in cases of imminent danger, infractions of Contractor's Safety Plan, CAL/OSHA, FEDERAL OSHA, ANSI or other applicable safety standards.
- (g) An amount not to exceed twenty percent (20%) of the total progress payment, due to four or more repeated infractions in a single payment period of Contractor's Safety Plan CAL/OSHA, FEDERAL OSHA, ANSI and all other applicable safety standards.
- (h) Items listed in **Appendix B Contracts Data Requirements List** or **Section 8 Technical Specifications** that are not received within the time specified. The amount withheld may be ten percent (10%) of the total progress payment or \$10,000, whichever is greater. Contractor's failure to submit any required items may subject it to the remedies of **Section 7.71 Termination for Default**.
- (i) Any and all other circumstances in which VTA determines that it is necessary to protect its interests.

Whenever VTA withholds special retention, written notice of the amount withheld and the reasons therefore shall be given Contractor. When Contractor removes the grounds for such withholding, VTA will include the amount so withheld in the next scheduled progress payment.

#### **7.59.7. Substitution of Securities**

Securities may be substituted in lieu of the withholding of retention from progress payments in accordance with **Public Contract Code § 22300**, which states.

##### **§ 22300 Performance retentions; provision for substitute security; escrow agreement**

- (a) Provisions shall be included in any invitation for bid and in any contract documents to permit the substitution of securities for any moneys withheld by a public agency to ensure performance

under a contract however, substitution of securities provisions shall not be required in contracts in which there will be financing provided by the Farmers Home Administration of the United States Department of Agriculture pursuant to the Consolidated Farm and Rural Development Act (7 U.S.C. § 1921 et. seq.), and where federal regulations or policies, or both, do not allow the substitution of securities. At the request and expense of Contractor, securities equivalent to the amount withheld shall be deposited with the public agency, or with a state or federally chartered bank in this state as the escrow agent, who shall then pay those moneys to the Contractor. Upon satisfactory completion of the contract, the securities shall be returned to Contractor.

(b) Alternatively, Contractor may request and the owner shall make payment of retentions earned directly to the escrow agent at the expense of Contractor. At the expense of Contractor, Contractor may direct the investment of the payments into securities and Contractor shall receive the interest earned on the investments upon the same terms provided for in this section for securities deposited by Contractor. Upon satisfactory completion of the contract, Contractor shall receive from the escrow agent all securities, interest, and payments received by the escrow agent from the owner, pursuant to the terms of this section.

(c) Securities eligible for investment under this section shall include those listed in Section 16430 of the Government Code, bank or savings and loan certificates of deposit, interest-bearing demand deposit accounts, standby letters of credit, or any other security mutually agreed to by Contractor and the public agency.

The Contractor shall be the beneficial owner of any securities substituted for moneys withheld and shall receive any interest thereon.

Failure to include these provisions in bid and contract documents shall void any provisions for performance retentions in a public agency contract.

For purposes of this section, the term "public agency" shall include, but shall not be limited to, chartered cities.

(d) (1) Any contractor who elects to receive interest on moneys withheld in retention by a public agency shall, at the request of any subcontractor, make that option available to the subcontractor regarding any moneys withheld in retention by the contractor from the subcontractor. If the contractor elects to receive interest on any monies withheld in retention by a public agency, then the subcontractor shall receive the identical rate of interest received by the contractor on any retention moneys withheld from the subcontractor by the contractor, less any actual pro rata costs associated with administering and calculating that interest. In the event that the interest rate is a fluctuating rate, the rate for the subcontractor shall be determined by calculating the interest rate paid during the time that retentions were withheld from the subcontractor. If the contractor elects to substitute securities in lieu of retention, then, by mutual consent of the contractor and subcontractor, the subcontractor may substitute securities in exchange for the release of moneys held in retention by the contractor.

(2) This subdivision shall apply only to those subcontractors performing more than five percent of the contractor's total Bid.

(3) No contractor shall require any subcontractor to waive any provision of this section.

(e) The Legislature hereby declares that the provisions of this section are of statewide concern and are necessary to encourage full participation by Contractors and subcontractors in public contract procedures.

(f) The escrow agreement used hereunder shall be null, void, and unenforceable unless it is substantially similar to the following form:

ESCROW AGREEMENT FOR SECURITY DEPOSITS IN LIEU OF RETENTION

This Escrow Agreement is made and entered into as of \_\_\_\_\_, 201\_\_ by and between \_\_\_\_\_, whose address is \_\_\_\_\_ hereinafter called "Owner," \_\_\_\_\_ whose address is \_\_\_\_\_ hereinafter called "Contractor" and \_\_\_\_\_, a state or federally chartered bank, whose address is \_\_\_\_\_ hereinafter called "Escrow Agent."

For the consideration hereinafter set forth, the Owner, Contractor, and Escrow Agent agree as follows:

(1) Pursuant to Section 22300 of the Public Contract Code of the State of California, Contractor has the option to deposit securities with Escrow Agent as a substitute for retention earnings required to be withheld by Owner pursuant to the Construction Contract entered into between the owner and Contractor for \_\_\_\_\_ in the amount of \_\_\_\_\_ dated \_\_\_\_\_ (hereinafter referred to as the "Contract"). Alternatively, on written request of Contractor, the owner shall make payments of the retention earnings directly to the Escrow Agent. When Contractor deposits the securities as a substitute for Contract earnings, the Escrow Agent shall notify the Owner within 10 days of the deposit. The market value of the securities at the time of the substitution shall be at least equal to the cash amount then required to be withheld as retention under the terms of the Contract between the owner and Contractor. Securities shall be held in the name of \_\_\_\_\_, and shall designate Contractor as the beneficial owner.

(2) The Owner shall make progress payments to Contractor for those funds which otherwise would be withheld from progress payments pursuant to the Contract provisions, provided that the Escrow Agent holds securities in the form and amount specified above.

(3) When the Owner makes payment of retentions earned directly to the Escrow Agent, the Escrow Agent shall hold them for the benefit of the contractor until the time that the escrow created under this contract is terminated. The contractor may direct the investment of the payments into securities. All terms and conditions of this agreement and the rights and responsibilities of the parties shall be equally applicable and binding when the Owner pays the Escrow Agent directly.

(4) Contractor shall be responsible for paying all fees for the expenses incurred by Escrow Agent in administering the Escrow Account and all expenses of the Owner. These expenses and payment terms shall be determined by the Owner, Contractor, and Escrow Agent.

(5) The interest earned on the securities or the money market accounts held in escrow and all interest earned on that interest shall be for the sole account of Contractor and shall be subject to withdrawal by Contractor at any time and from time to time without notice to the Owner.

(6) Contractor shall have the right to withdraw all or any part of the principal in the Escrow Account only by written notice to Escrow Agent accompanied by written authorization from the Owner to the Escrow Agent that Owner consents to the withdrawal of the amount sought to be withdrawn by Contractor.

(7) The Owner shall have a right to draw upon the securities in the event of default by Contractor. Upon seven days' written notice to the Escrow Agent from the owner of the default, the Escrow Agent shall immediately convert the securities to cash and shall distribute the cash as instructed by the Owner.

(8) Upon receipt of written notification from the owner certifying that the Contract is final and complete, and that Contractor has complied with all requirements and procedures applicable to the Contract, Escrow Agent shall release to Contractor all securities and interest on deposit less escrow fees and charges of the Escrow Account. The escrow shall be closed immediately upon disbursement of all moneys and securities on deposit and payments of fees and charges.

(9) Escrow Agent shall rely on the written notifications from the owner and Contractor pursuant to Sections (6) to (8), inclusive, of this agreement and the owner and Contractor shall hold Escrow Agent harmless from Escrow Agent's release and disbursement of the securities and interest as set forth above.

(10) The names of the persons who are authorized to give written notice or to receive written notice on behalf of the owner and on behalf of Contractor in connection with the foregoing, and exemplars of their respective signatures are as follows:

On behalf of Owner [For withdrawal or release specified in paragraphs (6) to (8)]:

\_\_\_\_\_ (Title)  
\_\_\_\_\_ (Name)  
\_\_\_\_\_ (Signature)  
\_\_\_\_\_ (Address)

On behalf of Contractor:

\_\_\_\_\_ (Title)  
\_\_\_\_\_ (Name)  
\_\_\_\_\_ (Signature)  
\_\_\_\_\_ (Address)

On behalf of Escrow Agent:

\_\_\_\_\_ (Title)  
\_\_\_\_\_ (Name)  
\_\_\_\_\_ (Signature)  
\_\_\_\_\_ (Address)

(11) In accordance with Section 22300(c) of the Public Contract Code securities eligible for deposit by Contractor or investment hereunder shall be \_\_\_\_\_ and no others.

At the time the Escrow Account is opened, the Owner and Contractor shall deliver to the Escrow Agent a fully executed counterpart of this Agreement.

IN WITNESS WHEREOF, the parties have executed this Agreement by their proper officers on the date first set forth above.

OWNER

\_\_\_\_\_ (Title)  
\_\_\_\_\_ (Name)  
\_\_\_\_\_ (Signature)

CONTRACTOR

\_\_\_\_\_ (Title)  
\_\_\_\_\_ (Name)  
\_\_\_\_\_ (Signature)

ESCROW AGENT

\_\_\_\_\_ (Title)  
\_\_\_\_\_ (Name)  
\_\_\_\_\_ (Signature)

### **7.60. Force Account Payment**

If work is directed by VTA to be performed on a force account basis, compensation shall be made as set forth in this provision. Such payment shall constitute full compensation to Contractor for work directed to be performed on force account and no additional compensation will be allowed therefore. Labor, materials and equipment used in the performance of work on a force account basis shall be approved daily by VTA.

#### **7.60.1. Work Performed by Contractor**

Contractor will be paid the direct costs for labor, materials and equipment used in performing the Work as hereinafter provided except where agreement has been reached to pay in accordance with **Section 7.60.7 Work Performed by Special Forces**. A markup may be added to the total of the direct costs computed as provided in **Section 7.60.2 Labor**, **Section 7.60.3 Materials**, and **Section 7.60.4 Equipment Rental**. The added markup shall not exceed twenty percent (20%) of the cost of labor, fifteen percent (15%) of the cost of material, fifteen percent (15%) of equipment rental and five percent (5%) of the cost of subcontractors, including trucking.

The above markups shall constitute full compensation for all overhead costs (general overhead, bonding, supervision, office expenses, field office facilities, utilities, and transportation) and profit which shall be deemed to include all items of expense not specifically designated as cost or equipment rental in **accordance with Section 7.60.2 Labor, Section 7.60.3 Materials, and Section 7.60.4 Equipment Rental**.

When work paid for on a force account basis is performed by forces other than Contractor's organization, Contractor shall reach agreement with such other forces as to the distribution of the payment made by VTA for such work. No additional payment therefore will be made by VTA by reason of the performance of the Work by a subcontractor or other forces.

#### **7.60.2. Labor**

Contractor will be paid the cost of labor for the workmen (including foremen when authorized by VTA) used in the actual and direct performance of the Work. The cost of labor, whether the employer is Contractor, subcontractor, or other forces, will be the sum of the following:



- **Actual Wages.** The actual wages paid shall include any employer payments to or on behalf of the workmen for health and welfare, pension, vacation, insurance, overtime, plus other additives in accordance with collective bargaining agreements
- **Labor Surcharge.** To the actual wages, as defined above, will be added a Labor Surcharge as set forth in the State of California Department of Transportation publication entitled *Labor Surcharge & Equipment Rental Rates*, which was in effect on the date upon which the Work was accomplished. Said labor surcharge shall constitute full compensation for all payments imposed by State and Federal laws and for all other payments made to, or on behalf of, the workmen, other than actual wages as defined above and the actual subsistence and travel allowance.

### **7.60.3. Materials**

VTA reserves the right to furnish such materials as it deems advisable, and Contractor shall have no claims for costs and markup on such materials.

Only materials furnished by Contractor and necessarily used in the performance of the Work will be paid for by VTA. The cost of such materials will be the cost to the purchaser, whether Contractor, subcontractor or other forces, from the supplier thereof, except as the following are applicable:

- (a) If a cash or trade discount by the actual supplier is offered or available to the purchaser, it shall be credited to VTA notwithstanding the fact that such discount may not have been taken.
- (b) If materials are procured by the purchaser by any method which is not a direct purchase from and a direct billing by the actual supplier to such purchaser, the cost of such materials shall be deemed to be the price paid to the actual supplier as determined by VTA. No markup except for actual costs incurred in the handling of such materials will be permitted.
- (c) If the materials are obtained from a supply or source owned wholly or in part by the purchaser, payment for these materials will not exceed the price paid by the purchaser for similar materials furnished from said source on contract items or the current wholesale price for such materials delivered to the jobsite, whichever price is lower.
- (d) If the cost of such materials is, in the opinion of VTA, excessive, then the cost of such material shall be deemed to be the lowest current wholesale price at which such materials are available in quantities concerned delivered to the jobsite, less any discounts as provided above.

### **7.60.4. Equipment Rental**

Compensation for equipment used on force account work shall be determined from the latest schedule of equipment rental rates listed in the State of California, Business, Transportation and Housing Agency, Department of Transportation, Division of Construction Publication entitled *Labor Surcharge & Equipment Rental Rates* and in use at the time the equipment is used. The equipment rental rates listed in said publication shall be used regardless of ownership and any rental or other agreement, if such may exist for the use of such equipment entered into by Contractor. If it is deemed necessary by VTA to use equipment not listed in the publication, a suitable rental rate for such equipment will be established by VTA prior to the work being done. Contractor shall furnish any cost data which might assist VTA in the establishment of such rental rate.

The rental rate paid shall include the cost of fuel, oil, lubrication, supplies, small tools, necessary attachments, repairs and maintenance of any kind, depreciation, storage, insurance and all incidentals.

Any delay or overtime for equipment agreed to by VTA will be paid for in accordance with factors stated in the above referenced publication.

Operators of rental equipment will be paid for as provided in **Section 7.60.2 Labor**.

All equipment shall, in the opinion of VTA, be in good working condition and suitable for the purpose for which the equipment is to be used.

Unless otherwise specified, manufacturer's ratings and manufacturer approved modifications shall be used to classify equipment for the determination of applicable rental rates. Equipment which has no direct power unit shall be powered by a unit of at least the minimum rating recommended by the manufacturer.

Individual pieces of equipment or tools having a replacement value of \$250 or less, whether or not consumed by use, shall be considered to be small tools and no payment will be made therefore.

Rental time will not be allowed while equipment is inoperative due to breakdowns.

#### **7.60.5. Equipment at the Worksite**

The rental time to be paid for equipment on the Work shall be the time the equipment is in operation on the Work being performed, and in addition, shall include the time required to move the equipment to the location of the Work and return it to the original location or to another location requiring no more time than that required to return it to its original location, except that moving time will not be paid for if the equipment is used at the Worksite on other than such work. Loading and transporting costs will be allowed, in lieu of moving time, when the equipment is moved by means other than its own power, except that no payment will be made if the equipment is used at the Worksite on other than such Work.

The following shall be used in computing the rental time of equipment on the Work:

- When hourly rates are listed, less than 30 minutes of operation shall be considered to be one-half hour of operation.
- When daily rates are listed, less than 4 hours of operation shall be considered to be one-half day of operation.

#### **7.60.6. Equipment Not at the Worksite**

For the use of equipment moved onto the Worksite and used exclusively for work paid for on a force account basis Contractor will be paid the rental rates as determined in **Section 7.60.4 Equipment Rental**, and for the cost of transporting the equipment to the location of the Work and its return to its original location, all in accordance with the following provisions:

- The original location of the equipment to be hauled to the location of the Work shall be agreed to by VTA in advance.
- VTA will pay the cost of loading and unloading such equipment.
- The cost of transporting equipment in low bed trailers shall not exceed the hourly rates listed in the State of California Department of Transportation publication entitled Labor Surcharge & Equipment Rental Rates.

- The cost of transporting equipment shall not exceed the applicable minimum established rates of the Public Utilities Commission.

The rental period shall begin at the time the equipment is unloaded at the site of the Work, shall include each day that the equipment is at the site of the Work, excluding Saturdays, Sundays, and VTA holidays unless the equipment is used to perform the Work on such days, and shall terminate at the end of the day on which VTA directs Contractor to discontinue the use of such equipment. The rental time to be paid per day will be in accordance with the following:

Hours of Operation	Hours to be paid
0.....	4
0.5.....	4.25
1.....	4.5
1.5.....	4.75
2.....	5
2.5.....	5.25
3.....	5.5
3.5.....	5.75
4.....	6
4.5.....	6.25
5.....	6.5
5.5.....	6.75
6.....	7
6.5.....	7.25
7.....	7.5
7.5.....	7.75
8.....	8
Over 8.....	Actual hours in operation

The hours to be paid for equipment which is operated less than 8 hours due to breakdowns, shall not exceed 8 less the number of hours the equipment is inoperative due to breakdowns.

When hourly rates are listed, less than 30 minutes of operation shall be considered to be one-half hour of operation. When daily rates are listed, payment for one-half day will be made if the equipment is not used. If the equipment is used, payment will be made for one day. The minimum rental time to be paid for the entire rental period on an hourly basis shall not be less than 8 hours or if on a daily basis shall not be less than one day.

Should Contractor desire the return of the equipment to a location other than its original location, VTA will pay the cost of transportation in accordance with the above provisions, provided such payment shall not exceed the cost of moving the equipment to the Work.

Payment for transporting, and loading and unloading equipment, as provided above, will not be made if the equipment is used on the Work in any other way than upon Work paid for on a force account basis

When work, other than work specifically designated as Work in the Contract Documents, is to be paid for on a force account basis and VTA determines that such work requires Contractor to move equipment onto the Worksite which could not reasonably have been expected to be needed in the performance of the

Contract, payment for the use of such equipment at equipment rental rates in excess of those listed as applicable for the use of such equipment will be made subject to the following additional conditions:

- VTA shall specifically approve the necessity for the use of particular equipment on such Work.
- Contractor shall establish to the satisfaction of VTA that such equipment cannot be obtained from its normal equipment source or sources and those of its subcontractors.
- Contractor shall establish to the satisfaction of VTA that the proposed equipment rental rate for such equipment from its proposed source is reasonable and appropriate for the expected period of use.
- VTA shall approve the equipment source and the equipment rental rate to be paid by VTA before Contractor begins work involving the use of said equipment.

#### **7.60.7. Work Performed by Special Forces or Other Special Services**

When VTA and Contractor, by mutual agreement, determine that a special service or an item of work cannot be performed by the forces of Contractor, or those of any of its subcontractors, such service or work item may be performed by a specialist. Payment for such service or item of work, performed by a specialist on the basis of the current market price thereof, may be accepted without complete itemization of labor, material, and equipment rental costs when it is impracticable and not in accordance with the established practice of the special service industry to provide such complete itemization.

In those instances wherein a Contractor is required to perform work necessitating a fabrication or machining process in a fabrication or machine shop facility away from the jobsite, the charges for that portion of the Work performed in such a facility, may, by mutual agreement, be accepted as a specialist billing.

In lieu of the percent markups provided above in **Section 7.60.1 Work Performed by Contractor**, a markup not to exceed fifteen percent (15%) will be added to the specialist price, less a credit to VTA for any cash or trade discount offered or available, whether or not such discount may have been taken.

#### **7.60.8. Owner-Operated Equipment**

When "Owner-Operated Equipment" is used to perform work to be paid on a force account basis, Contractor will be paid for the equipment and operator, as follows:

- Payment for the Equipment will be made in accordance with **Section 7.60.4 Equipment Rental**.
- Payment for the cost of labor and subsistence or travel allowance will be made at the rates paid by Contractor to other workmen operating similar equipment already on the project or, in the absence of such other workmen, at the rates for such labor established by collective bargaining agreements for the type of workmen and location of the Work, whether or not the "Owner-Operator" is actually covered by such an agreement. A labor surcharge will be added to the cost of labor described herein, in accordance with the provisions of Subsection entitled "Labor Surcharge."
- To the direct cost of equipment rental and labor, computed as provided herein, will be added the markups for labor and equipment rental as provided in **Section 7.60.1 Work Performed by Contractor**.

If, at any time after Contractor commences the force account work, a method of compensation other than that specified in this **Section 7.60** has been agreed upon for the force account work or a portion of such work, such compensation shall be made in accordance with such agreement.

Contractor shall keep accurate daily records of the actual cost to Contractor for all work performed pursuant to this **Section 7.60** and shall make them available to VTA upon reasonable notice and request. Such records shall be maintained in such a manner so as to be completely discernible from records associated with the basic Contract scope.

## **7.61. Prompt Payment**

### **7.61.1. Prompt Payment to Contractor**

**Public Contract Code Section 20104.50** requiring prompt payment to Contractors is applicable to this contract. Undisputed and properly submitted payment requests shall be paid within thirty (30) days of receipt by VTA. Any undisputed and properly submitted payment request not paid within thirty (30) days shall accrue interest at the legal rate set forth in **Code of Civil Procedure Section 685.010**.

A certified **Progress Payment – Form B document**, as described in **Section 7.59 Progress Payments** shall constitute a payment request. Any payment request determined by VTA not to be a proper payment request shall be returned to Contractor within seven (7) days of receipt setting forth in writing the reasons why the payment request is not proper.

### **7.61.2. Payment to Subcontractors**

Contractor shall adhere to all federal and California prompt payment laws and regulations including **Business and Professions Code Section 7108.5** requiring Contractor to pay subcontractors within seven (7) days of receipt of each progress payment to the extent of each subcontractor's interest therein, unless otherwise agreed to in writing between Contractor and the subcontractor.

Any violation of this provision shall subject Contractor or subcontractor to the penalties, sanctions and other remedies specified in **Section 7108.5 of the California Business and Professions Code**. This requirement shall not be construed to limit or impair any contractual, administrative, or judicial remedies otherwise available to Contractor or subcontractor in the event of a dispute involving late payment or nonpayment by Contractor or deficient subcontract performance, or noncompliance by a subcontractor.

This provision applies to all contractors and subcontractors.

Contractor must include in its subcontract language a provision that it will use appropriate alternative dispute resolution mechanisms to resolve any payment disputes with subcontractors or suppliers.

Any subcontract entered into as a result of this Contract shall contain all of the provisions of this section.

## **7.62. Final Payment**

Final payment shall not become due until the following actions have been satisfactorily completed:

- Satisfactory completion of final inspection of all the Work under the Contract
- Contractor submittal to VTA of:
  - An affidavit that all payrolls, bills for materials and equipment, and other indebtedness connected with the Work have been paid or otherwise satisfied, and

- A release of liens and claims arising out of the Contract, to the extent and in the form designated by VTA. If a claim remains unsatisfied after all payments are made, Contractor shall reimburse VTA for all monies that VTA may be compelled to pay in discharging the claim, including all costs and reasonable attorney's fees.
- Issuance by VTA of a Letter of Final Acceptance of the Work.
- The recording of a Notice of Completion by VTA.

VTA may at its option and at any time retain out of any amounts due Contractor, sums sufficient to cover claims, filed pursuant to California Civil Code Section 9000 et seq.

VTA will make final payment within **30-60 calendar days** of the recording of the Notice of Completion.

The acceptance of final payment by Contractor shall constitute a waiver of all claims against VTA arising under the Contract.

### **7.63. Project Records**

Comprehensive records and documentation relating to this project shall be kept by Contractor and all subcontractors. The records shall include, but are not limited to Contract Documents, Drawings, Specifications, Addenda, Shop Drawings and Submittals, Change Orders, Modifications, Test Records, redline construction plans, As-Built Drawings, and cost and pricing data. Contractor shall maintain a complete set of records relating to this Contract for a period of seven years from final payment for this Work.

The cost records shall be complete and in sufficient detail to allow evaluation of the accuracy and completeness, and currency of the costs or prices. Contractor shall permit the authorized representatives of VTA, the U.S. Department of Transportation, and the Comptroller General of the United States to examine and audit all such records and any subcontracts under this Contract during the time period so specified. In addition, **every contract and subcontract involving the expenditure of public funds in excess of ten thousand dollars (\$10,000) entered into by a public entity in the State of California shall be subject to the examination and audit of the State Auditor**, at the request of the public entity or as part of any audit of the public entity, for a period of three years after final payment under the Contract.

## CONTRACT MODIFICATIONS, DISPUTES AND CLAIMS

### **7.64. Reserved**

### **7.65. Change Requests and Change Notices**

#### **7.65.1. Change Request**

Contractor may make a written request to VTA to modify the Contract (Change Request) based upon the receipt of, or the discovery of information that changes the scope, price, schedule, level of performance, or other facet of the Contract.

Contractor shall deliver a document entitled "Change Request" to VTA within thirty (30) days after receipt of, or the discovery of, information (other than receipt of a "Change Notice") that Contractor believes will cause a change to the scope, price, schedule, level of performance, or other facet of the Contract. Upon receipt of a Change Notice, Contractor shall follow the procedures of **Section 7.65.2 Change Notice**. All Change Requests, and any Claims based thereon including any request or claim for cumulative impact

costs shall be deemed waived unless a Change Request is delivered to VTA within the thirty (30) calendar days specified herein.

The Change Request shall include information necessary to substantiate the effect of the change and any impacts to the Work, including any change in schedule or Contract Price, and shall include all existing documentation or a description of anticipated documentation. In addition, the Change Request shall contain a detailed description of the proposed adjustment to the Contract Price or currently approved progress schedule, or both, and shall reference any other provisions of the Contract that will require modification because of the change. If a Change Request proposes an adjustment in the Contract Price, upon request of VTA, Contractor shall submit a complete breakdown of costs including detailed pricing and back up information for all work and any impacts thereto contemplated by the change.

The unavailability of all information necessary to quantify the change shall not excuse the timely submission of the Change Request. Contractor shall supplement the Change Request with additional information or documentation, as it becomes available. If VTA has not received sufficient substantiating documentation or information within a reasonable time after receipt of the Change Request, such insufficiency may be grounds to deny the Change Request.

If a Change Request or portions thereof are acceptable to VTA, VTA will issue a Contract Change Order consistent therewith. If a Change Request or portions thereof are not acceptable to VTA, VTA shall notify Contractor in writing.

Any request by Contractor to modify the Contract must first be submitted to VTA and proceed as a Change Request pursuant to these provisions. Contractor may submit the matter as a Claim pursuant to **Section 7.68 Claims and Claim Resolution** only if: (i) the Change Request has been denied by VTA in whole or in part; or (ii) the Change Request has not been resolved within ninety (90) days after receipt by VTA.

In the event of a dispute, Contractor shall proceed with the Work without delay, as directed by VTA.

#### **7.65.2. Change Notices**

VTA may, at any time during performance of the Contract notify Contractor of changes to the Contract by issuing a **Change Notice** to that effect. Contractor shall, within fifteen (15) days after receipt of such Change Notice, provide to VTA a written response identifying any proposed adjustment in Contract Price, including any adjustment for cumulative impact costs and schedule to perform the changes identified in the Change Notice, unless another time period for response is specified in the Change Notice. Upon request of VTA, Contractor shall submit a complete breakdown of costs including detailed pricing information and backup for all work and any impacts thereto caused by the change. VTA shall then issue an appropriate change order.

If VTA directs Contractor to perform additional work, the basis for compensation for such work shall be either: 1) increase in quantity of a Contract Item(s), 2) negotiated lump sum price, 3) unit prices mutually agreed upon under the Schedule of Values, or 4) force account, as determined by VTA. The markups described in **Section 7.60.1 Work Performed by Contractor** shall be the maximum allowed for all additional work directed by VTA.

VTA retains the right to direct Contractor to complete a portion of the Work at a time different than that specified in the Contract or reflected in the currently approved progress schedule. Such direction will be in writing and will provide for an equitable adjustment in the compensation to be paid to Contractor, if any. If such direction modifies the amount of compensation or time required for the completion of the Work, an appropriate change order will be issued.

If Contractor and VTA cannot agree on the appropriate adjustment to the Contract Price or schedule, Contractor may either accept VTA's determination or identify and submit the matter as a Claim pursuant to the provisions of **Section 7.68 Claims and Claim Resolution**. In the event of a dispute, Contractor shall proceed with the Work without delay as directed by VTA.

### **7.66. Change Order**

A change order is a written document issued by VTA, that:

- Changes the Total Contract Price, as modified by any previously executed change orders, or
- Alters the scope of Work under the Contract, or
- Alters the schedule for performance of the Work under the Contract as set forth in the currently approved schedule, or
- Makes any other change to the Contract, or makes a combination of any of the aforementioned Contract changes.

### **7.67. Differing Site Conditions**

#### **7.67.1. Soil Boring or Other Data**

Where VTA has included soil boring information or other data in the Contract, they are included for Contractor's information only and VTA does not guarantee the accuracy of the information contained therein.

#### **7.67.2. Notice of Differing Conditions**

Contractor shall promptly and before such conditions are disturbed, notify VTA in writing of subsurface or latent physical conditions at the site differing materially from those indicated in the Contract, or unknown physical conditions at the site, of any unusual nature, differing materially from those ordinarily encountered and generally recognized as inherent in work of the character provided for in this Contract.

All Change Requests involving differing site conditions and any Claims based thereon shall be deemed waived unless Contractor has given written notice before the conditions are disturbed as specified herein.

VTA will, as soon as practicable, investigate or cause to be investigated the items noted by Contractor and, if it is determined that such conditions do materially so differ and cause an increase or decrease in Contractor's cost of or time required for the performance of any part of the Work under the Contract, whether or not changed as a result of such conditions, an equitable adjustment will be made and the Contract modified.

### **7.68. Claims and Claim Resolution**

As required by law, VTA sets forth the provisions of **Public Contract Code section 9204**, which apply to all claims by a contractor in connection with a public works project.

#### **7.68.1. Claim Defined**

"Claim" means a separate demand by Contractor, sent by registered mail or certified mail with return receipt requested for:



- A time extension, including, without limitation, for relief from damages or penalties for delay assessed by a VTA under a contract for a public works project;
- Payment by VTA of money or damages arising from work done by, or on behalf of, Contractor pursuant to the Contract and payment for which is not otherwise expressly provided or to which the claimant is not otherwise entitled to; or
- Payment of an amount that is disputed by VTA.

#### **7.68.2. Claim Requirements**

Claim requirements are as follows:

- (a) Any submittal intended by Contractor to be evaluated by VTA as a Claim shall be entitled "Claim"
- (b) All Claims must be submitted by Contractor within thirty (30) days after the date of the event giving rise to the Claim, such as, for example, the denial by VTA of a Change Request, the failure of VTA to respond to a Change Request within ninety (90) days after receipt of required substantiating information and documentation, or the issuance by VTA of a disputed Change Order. Any Claim not submitted within the specified thirty (30) days is waived.
- (c) Claims must be in writing and must be submitted with all documents reasonably necessary to substantiate the Claim. A Claim must state in as much detail as possible the basis for the Claim and the additional compensation or extra time to which Contractor believes it is entitled. If the Claim is silent regarding entitlement to extra time, Contractor is not entitled to any extra time in connection with the Claim. If the Claim is silent regarding additional compensation, Contractor is not entitled to any additional compensation in connection with the Claim.
- (d) Contractor must notify VTA promptly in writing of any changes in its estimates of additional compensation or extra time, and the notification must state the reasons for the changes.
- (e) All Claims and any amendments thereto shall include the fully executed certification set forth below. Any Claim submitted without a fully executed certification shall be rejected by VTA and returned to Contractor.

I, \_\_\_\_\_, BEING THE \_\_\_\_\_ (MUST BE AN OFFICER) OF \_\_\_\_\_ (CONTRACTOR), DECLARE UNDER PENALTY OF PERJURY UNDER THE LAWS OF THE STATE OF CALIFORNIA, AND DO PERSONALLY CERTIFY AND ATTEST THAT I HAVE THOROUGHLY REVIEWED THE ATTACHED CLAIM FOR ADDITIONAL COMPENSATION AND/OR EXTENSION OF TIME, AND KNOW ITS CONTENTS, AND SAID CLAIM IS MADE IN GOOD FAITH; THE SUPPORTING DATA IS TRUTHFUL AND ACCURATE; THAT THE AMOUNT REQUESTED ACCURATELY REFLECTS THE CONTRACT ADJUSTMENT FOR WHICH CONTRACTOR BELIEVES THE OWNER IS LIABLE; AND, FURTHER, THAT I AM FAMILIAR WITH CALIFORNIA PENAL CODE SECTION 72 AND CALIFORNIA GOVERNMENT CODE SECTION 12650 ET SEQ, PERTAINING TO FALSE CLAIMS, AND FURTHER KNOW AND UNDERSTAND THAT SUBMISSION OR CERTIFICATION OF A FALSE CLAIM MAY LEAD TO FINES, IMPRISONMENT, AND/OR OTHER SEVERE LEGAL CONSEQUENCES.

By \_\_\_\_\_

(f) Contractor may not file any Claims after the date of final payment.

### **7.68.3. Claim Review**

VTA will conduct a reasonable review of the claim and respond in writing to Contractor's Claim within forty-five (45) calendar days after VTA's receipt of the Claim.

VTA's written response will identify what portion of the Claim is disputed and what portion is undisputed.

VTA and Contractor may, by mutual agreement extend the time period for VTA's review and response to the Claim.

If VTA needs approval from its governing body to provide Contractor a written statement identifying the disputed portion and the undisputed portion of the claim, and the governing body does not meet within the 45 days or within the mutually agreed to extension of time following receipt of a claim sent by registered mail or certified mail, return receipt requested, the public entity shall have up to three days following the next duly publicly noticed meeting of the governing body after the 45-day period, or extension, expires to provide the claimant a written statement identifying the disputed portion and the undisputed portion.

### **7.68.4. Payment of Undisputed Portion**

Any payment due on an undisputed portion of the claim shall be processed and made within 60 days after VTA issues its written statement. If VTA fails to issue a written statement within the time specified or agreed, **Section 7.68.5 Meet and Confer** will apply.

### **7.68.5. Meet and Confer**

If Contractor disputes VTA's written response, or if VTA fails to respond to a Claim within the time prescribed, Contractor may so notify VTA, in writing, either within fifteen (15) days of receipt of VTA's response or within fifteen (15) days of VTA's failure to respond within the time prescribed, respectively, and demand an informal conference to meet and confer for settlement of the issues in dispute. Upon a demand, VTA shall schedule a meet and confer conference within thirty (30) days for settlement of the dispute.

Within 10 working days following the conclusion of the meet and confer conference, if the Claim or any portion of the Claim remains in dispute, VTA shall provide Contractor a written statement identifying the portion of the Claim that remains in dispute and the portion that is undisputed.

Any payment due on the undisputed portion of the Claim following the meet-and-confer conference shall be processed and made within 60 days after VTA issues its written statement.

Any disputed portion of the Claim, as identified by Contractor in writing, shall be submitted to nonbinding mediation, with VTA and Contractor sharing the associated costs equally. VTA and Contractor shall mutually agree to a mediator within 10 working days after the disputed portion of the claim has been identified in writing. If the parties cannot agree upon a mediator, each party shall select a mediator and those mediators shall select a qualified neutral third party to mediate with regard to the disputed portion of the Claim. Each party shall bear the fees and costs charged by its respective mediator in connection with the selection of the neutral mediator. If mediation is unsuccessful, the parts of the Claim remaining in dispute shall be subject to all other applicable contractual and legal provisions.

For purposes of this **Section 7.68.5**, mediation includes any nonbinding process, including, but not limited to, neutral evaluation or a dispute review board, in which an independent third party or board assists the

parties in dispute resolution through negotiation or by issuance of an evaluation. Any mediation utilized shall conform to the timeframes in this **Section 7.68.5**.

Following the meet and confer conference, if the Claim or any portion remains in dispute, Contractor may file a Government Code claim as provided in Chapter 1 (commencing with Section 900) and Chapter 2 (commencing with Section 910) of Part 3 of Division 3.6 of Title 1 of the Government Code. For purposes of those provisions, the running of the period of time within which a Government Code claim must be filed shall be tolled from the time Contractor submits its written Claim pursuant to the above provisions until the time the Claim is denied as a result of the meet-and-confer process, including any period of time utilized by the meet-and-confer process.

The above procedures do not apply to Government Code claims for tort damages and are not intended, and shall not be construed, to change the time for filing such claims.

#### **7.68.6. Inaction Deemed Rejection**

Failure by VTA to respond to a Claim within the time periods described in this **Section 7.68** or to otherwise meet the time requirements of **Public Contract Code Section 9204** shall result in the claim being deemed rejected in its entirety. A Claim that is denied by reason of VTA's failure to have responded to a Claim, or its failure to otherwise meet the time requirements of Public Contract Code section 9204, shall not constitute an adverse finding with regard to the merits of the claim or the responsibility or qualifications of the claimant.

#### **7.68.7. Subcontractor Claims**

If a subcontractor or a lower tier subcontractor lacks legal standing to assert a claim against VTA because privity of contract does not exist, Contractor may present to VTA a Claim on behalf of a subcontractor or lower tier subcontractor. A subcontractor may request in writing, either on his or her own behalf or on behalf of a lower tier subcontractor, that Contractor present a Claim for work which was performed by the subcontractor or by a lower tier subcontractor on behalf of the subcontractor. The subcontractor requesting that the Claim be presented to VTA shall furnish reasonable documentation to support the claim. Within 45 days of receipt of this written request, Contractor shall notify the subcontractor in writing as to whether Contractor presented the claim to the public entity and, if the original contractor did not present the claim, provide the subcontractor with a statement of the reasons for not having done so.

#### **7.68.8. Waivers of Rights under Public Contract Code Section 9204**

A waiver of the rights granted by **Public Contract Code Section 9204** is void and contrary to public policy, provided, however, that (1) upon receipt of a Claim, the parties may mutually agree to waive, in writing, mediation and proceed directly to the commencement of a civil action or binding arbitration, as applicable; and (2) VTA may prescribe reasonable change order, claim, and dispute resolution procedures and requirements in addition to the provisions of this section, so long as the contractual provisions do not conflict with or otherwise impair the timeframes and procedures set forth in this section.

#### **7.68.9. Procedures for Civil Actions**

As required by law VTA sets forth below the provisions of **Public Contract Code Section 20104.4**, which applies to civil actions filed to resolve claims of \$375,000 or less:

- (a) Within 60 days, but no earlier than 30 days, following the filing of responsive pleadings, the court shall submit the matter to nonbinding mediation unless waived by mutual stipulation of both parties. The mediation process shall provide for the selection within 15 days by both*

*parties of a disinterested third person as mediator, shall be commenced within 30 days of the submittal, and shall be concluded within 15 days from the commencement of the mediation unless a time requirement is extended upon a good cause showing to the court or by stipulation of both parties. If the parties fail to select a mediator within the 15-day period, any party may petition the court to appoint the mediator.*

*(b) (1) If the matter remains in dispute, the case shall be submitted to judicial arbitration pursuant to Chapter 2.5 (commencing with Section 1141.10) of Title 3 of Part 3 of the Code of Civil Procedure, notwithstanding Section 1141.11 of that code. The Civil Discovery Act (Title 4 commencing with Section 2016.0103 of Part 4 of the Code of Civil Procedure) shall apply to any proceeding brought under this subdivision consistent with the rules pertaining to judicial arbitration.*

*(2) Notwithstanding any other provision of law, upon stipulation of the parties, arbitrators appointed for purposes of this article shall be experienced in construction law, and, upon stipulation of the parties, mediators and arbitrators shall be paid necessary and reasonable hourly rates of pay not to exceed their customary rate, and such fees and expenses shall be paid equally by the parties, except in the case of arbitration where the arbitrator, for good cause, determines a different division. In no event shall these fees or expenses be paid by state or county funds.*

*(3) In addition to Chapter 2.5 (commencing with Section 1141.10) of Title 3 of Part 3 of the Code of Civil Procedure, any party who after receiving an arbitration award requests a trial de novo but does not obtain a more favorable judgment shall, in addition to payment of costs and fees under that chapter, pay the attorney's fees of the other party arising out of the trial de novo.*

*(c) The court may, upon request by any party, order any witnesses to participate in the mediation or arbitration process.*

However, unless otherwise agreed to by VTA and Contractor in writing, the mediation conducted pursuant to this section shall excuse any further obligation under Section 20104.4 to mediate after litigation has been commenced.

The above claims procedures are also subject to **Public Contract Code § 20104.6**, which provides:

- (a) No local agency shall fail to pay money as to any portion of a claim which is undisputed except as otherwise provided in the Contract.*
- (b) In any suit filed under Section 20104.4, the local agency shall pay interest at the legal rate on any arbitration award or judgment. The interest shall begin to accrue on the date the suit is filed in a court of law.*

#### SUSPENSION OF WORK, CONTRACT TERMINATION

### **7.69. Suspension of Work**

In addition to the right of VTA to suspend Work under any other provision of this Contract, VTA may require Contractor to suspend all or part of the Work called for by this Contract at any time for up to **ninety (90) days** after a written Suspension Order is delivered to Contractor, and for any further period to which the parties may agree. The Suspension Order shall include the following:

- A clear description of the Work to be suspended;
- Guidance as to the action to be taken on subcontracts; and
- Other requests for minimizing costs.

Upon receipt of a Suspension Order, Contractor shall comply with its terms immediately and take all reasonable steps to minimize cost allocable to the Work covered by the Order during the period of work stoppage. Within the period specified by the Order, or within any extension of that period to which the parties may agree, VTA may:

- Terminate the Work covered by the Order as set forth in this section.
- Cancel the Suspension Order; or
- Allow the period of the Suspension Order to expire.

Contractor shall resume work upon the cancellation or expiration of a Suspension Order. An equitable adjustment shall be made in the Work scope, Contract Price, or Contract time, as appropriate, and the Contract shall be modified in writing in accordance with this section and **Section 7.32 Excusable Delays and Extensions of Time** if:

- The Suspension Order results in an increase in the time required for, or in Contractor's cost properly allocable to, the performance of any part of this Contract; and
- Contractor asserts a claim for an adjustment within thirty (30) days after the end of the period of work stoppage; and
- The Suspension Order was not caused by Contractor's default or other act or omission within the control or responsibility of Contractor.

In preparation for and during suspensions of work, Contractor shall take every reasonable precaution to prevent damage to or deterioration of the Work. Contractor shall repair or replace, at no cost to VTA, Work that is damaged or deteriorated during a work suspension due to Contractor's failure to comply with this duty. If VTA determines that Contractor is not taking reasonable precautions and Contractor fails to take the corrective action within five days after written notice from VTA, VTA may cause such action to be taken and recover the reasonable cost thereof from Contractor.

## **7.70. Termination for Convenience or in the Public Interest**

VTA may terminate the performance of Work in whole or in part at any time by written notice to Contractor if VTA determines that termination is in the best interest of VTA or the public. If performance of Work is so terminated, Contractor shall be entitled to payment for all Work performed acceptably and to payment for all acceptable goods or services ordered by and delivered to Contractor before termination, provided that Contractor provides a final itemized invoice, including all necessary documentation to substantiate all costs incurred, for the above amounts within thirty (30) days after receiving the termination notice.

## **7.71. Termination for Default**

### **7.71.1. Events or Conditions**

Contractor is in default under the Contract upon the occurrence of any one or more of the following events or conditions:

- (a) Contractor does not promptly begin the Work under the Contract Documents; or

- (b) Contractor does not perform the Work in accordance with the Contract Documents, including:
  - (i) conforming to applicable standards set forth therein in designing and/or constructing the Project, (ii) providing schedules or other documentation required by the Contract Documents, or (iii) refuses to remove and replace rejected materials or unacceptable Work; or
- (c) Contractor discontinues the prosecution of the Work (exclusive of work stoppage due to termination or suspension of the Work by VTA), does not prosecute the Work within the schedule, or prosecutes the Work so as to endanger the performance of this Contract in accordance with its terms; or
- (d) Contractor does not resume performance of Work which has been suspended or stopped, within a reasonable time after receipt of notice from VTA to do so or (if applicable) after cessation of the event preventing performance; or
- (e) Contractor becomes insolvent, or generally does not pay its debts as they become due, or admits in writing its inability to pay its debts or makes an assignment for the benefit of creditors; or
- (f) Insolvency, receivership, reorganization or bankruptcy proceedings are commenced by or against Contractor; or
- (g) Any representation or warranty made by Contractor in the Contract Documents or any certificate, schedule, instrument or other document delivered by Contractor pursuant to the Contract Documents is false or materially misleading when made; or
- (h) Contractor breaches any agreement, representation or warranty contained in the Contract Documents; or
- (i) Contractor assigns or transfers the Contract Documents or any right or interest herein, except as expressly permitted by the Contract Documents; or
- (j) Contractor does not discharge or obtain a stay of any final judgment(s) or order for the payment of money against it in excess of \$25,000 in the aggregate arising out of the prosecution of the Work (provided that for purposes hereof posting of a bond in the amount of 125 percent of such judgment or order shall be deemed an effective stay); or
- (k) Contractor does not, absent a valid dispute, make payment when due for labor, equipment or materials in accordance with its agreements with Subcontractors and applicable law; or
- (l) Contractor fails reasonably to comply with any instructions of VTA consistent with the Contract Documents; or
- (m) Contractor violates any laws, regulations and ordinances, or order of any government entity applicable to Contractor, the Work, or the Contract; or
- (n) Contractor does not provide and maintain the Performance and Payment Bonds and insurance as required hereunder; or
- (o) Contractor or one of its subcontractors causes, through its negligence, gross negligence, recklessness, or willful misconduct, death or grievous bodily injury to any person or property damage in excess of \$25,000; or

- (p) Contractor does not defend or indemnify any party that Contractor is obligated to defend or indemnify under the Contract Documents; or
- (q) Contractor offers or gives any improper consideration, in any form, either directly or through an intermediary, to any VTA director, officer, employee, contractor, or authorized representative, with the intent of securing the Contract or the making of any determination with respect to Contractor's performance of the Work; or
- (r) Contractor is placed on the California State Labor Commissioner's list of debarred contractors pursuant to **Labor Code §1771.1 or §1771.7**; or
- (s) Contractor or any of its directors, members, officers, partners, principals, employees, or any Contractor's representative is convicted for a violation of any Law related to Contractor's obligations under the Contract, including without limitation, in connection with the Work, goods supplied, payments to be made, or Claims submitted

### **7.71.2. Notice and Procedures**

Contractor and its Surety (as defined in the Performance Bond for Public Works required by this Contract (Performance Bond)) are entitled to seven (7) days' notice and opportunity to cure any breach described in **Sections 7.71.1 (a) through (d) and (i) through (l), and any non-material breach described in Sections 7.71.1 (h) or (m)**. Contractor and its Surety are entitled to three (3) days' notice and opportunity to cure any breach described **Sections 7.71.1 (n) and (p)**. Except as specified above, Contractor and its Surety have no right to notice or opportunity to cure with respect to any breach described in **Sections 7.71.1 (e), (f), (g), (h) (m), (o), or (q) through (s)**. If Contractor is unable to cure the applicable default within the time period specified, but in VTA's reasonable determination (i) Contractor has diligently and continuously undertaken efforts to cure such default, and (ii) such failure to cure is beyond the control of Contractor, VTA may extend the cure period in accordance with its discretion.

If any breach described in **Sections 7.71.1 (a) through (s)** is not subject to cure or is not cured within the period (if any) specified, VTA may declare that an "Event of Default" has occurred and notify Contractor to discontinue the Work. The declaration of an Event of Default must be in writing and given to Contractor and Surety. In addition to all other rights and remedies provided by law or equity and such rights and remedies as are otherwise available under the Contract and the Performance Bond, VTA may assume any of Contractor's subcontracts, appropriate any or all materials and equipment on the Worksite and any or all work product, including plans and specifications, as may be suitable and acceptable, and may direct the Surety to complete the Contract or may enter into an agreement for the completion of the Contract according to the terms and provisions hereof with another contractor or the Surety, or use such other methods as may be required for the completion of the Contract, including completion of the Work by VTA. Upon completion of such work, Contractor is entitled to return of all unused materials and its equipment, tools and appliances, except that there shall be no claim on account of usual and ordinary depreciation, loss, or wear and tear.

If Contractor's right to proceed is so terminated, Contractor shall not be entitled to receive any further payment until the Work is completed. Contractor and its surety(s) shall be liable to VTA for any additional costs of completion of the Work, including compensation for additional managerial and administrative services, plus liquidated damages accruing under the terms of this Contract from the Contract completion date, as extended by authorized time extensions, to the date of final completion.

If, after termination for failure to fulfill contract obligations, it is determined that Contractor was not in default, the rights and obligations of the parties shall be the same as if the termination had been issued for the convenience of VTA.

### **7.72. Contractor's Duties Upon Termination**

Immediately after receipt of a notice of termination, either for default or convenience (Notice of Termination), Contractor shall:

- Stop work under the Contract on the date and to the extent specified in the Notice of Termination;
- Place no further orders or subcontracts for materials, services, or facilities, except as may be necessary for completion of such portion of the Work under the Contract as is not terminated;
- Assign to VTA in a manner, at the times, and to the extent directed by VTA, all of the right, title, and interest of Contractor under the orders and subcontracts as designated by VTA;
- Terminate all other orders and subcontracts to the extent that they relate to the performance of Work terminated by the Notice of Termination; and
- Assign to VTA in a manner, at the times, and to the extent directed by VTA, all of the remaining right, title, and interest of Contractor under the orders and subcontracts so terminated.

### WARRANTY PROVISIONS

### **7.73. Warranty**

It is a condition of this Contract that the equipment, materials or design furnished, and workmanship performed by Contractor or any subcontractor or supplier at any tier, shall conform to the requirements of this Contract and shall be free of any defect. Neither inspection, testing and acceptance by VTA of such equipment, materials, design or work performed, partial or final payment, nor any provisions of the Contract relieves Contractor from responsibility for any latent defect, gross mistakes or fraud. Contractor and its surety(s) warrant all equipment, materials, design and workmanship for a period of one (1) year from the date of final acceptance by VTA of all, or, in VTA's sole discretion, a discrete portion of the Work. Contractor shall extend to VTA any warranty from a subcontractor or supplier that exceeds the above warranty period. If additional or varying guarantees are required, they will be specified in **Section 6 Special Conditions** of this contract. VTA retains the right, at its sole discretion, to assign to a third Party any warranty received under this Contract.

### **7.74. Warranty Work**

Contractor is responsible for all warranty-covered repair work during the warranty period as specified above. Contractor shall provide at its own expense all spare parts and tools required for repairs. To the extent practicable, VTA will allow Contractor or its Authorized Representative to perform such work. When warranty repairs are required, VTA and Contractor's Authorized Representative must confer on the most appropriate remedy to be performed within a reasonable time. If Contractor fails to remedy any failure or defect within a reasonable time, VTA shall have the right to replace, repair, or otherwise remedy the failure or defect at Contractor's expense. At its discretion, VTA may also perform such work if it deems necessary to do so to meet its operational commitments or other requirements. Contractor shall reimburse VTA for all expenses for such work including materials and labor. The hourly shop labor rates



shall be based on VTA's current labor cost accounting system. Contractor shall reimburse VTA for such work within sixty (60) days of receipt of warranty claim.

**7.75. Warranty on Repaired or Replaced Parts**

Contractor warrants any materials, parts or components which are used for replacement under the initial warranty period again for the total original warranty period of the replaced particular material, part or component.

**7.76. Systematic Failures**

In the event that, during the warranty period, repairs or modifications necessitated by defective design, material, or workmanship occur to an extent in excess of ten percent (10%) of the components used for the same function in the same assembly or subsystem purchased under this Contract, Contractor shall promptly furnish all necessary labor and material to effect such repairs and modifications for every system delivered under the Contract under the terms and conditions outlined, including systems in which the item has not yet failed. When requested by VTA, Contractor will be required to provide a written failure analysis report for defective products supplied under this Contract and which occurred during the warranty period. The report shall be received by VTA within forty-five (45) days from the date of request.

*[This Page Intentionally Left Blank]*

## SECTION 8 TECHNICAL SPECIFICATIONS

<b>DIVISION 1 – GENERAL REQUIREMENTS</b> .....	<b>8-9</b>
SECTION 01 10 00 – SUMMARY OF WORK .....	8-9
SECTION 01 12 92 – SCHEDULE OF VALUES .....	8-13
SECTION 01 31 19 – PROJECT MEETINGS .....	8-17
SECTION 01 73 00 – EXECUTION .....	8-21
SECTION 01 77 00 – CLOSEOUT PROCEDURES .....	8-31
SECTION 01 78 39 – PROJECT RECORD DOCUMENTS .....	8-35
<b>DIVISION 2 – EXISTING CONDITIONS</b> .....	<b>8-47</b>
SECTION 02 32 19 – POTHOLING.....	8-47
SECTION 02 41 19 – SELECTIVE DEMOLITION .....	8-49
SECTION 02 80 00 – HAZARDOUS MATERIAL REMOVALS .....	8-55
<b>DIVISION 3 – CONCRETE</b> .....	<b>8-61</b>
SECTION 03 10 00 – CONCRETE FORMING AND ACCESSORIES .....	8-61
SECTION 03 20 00 – CONCRETE REINFORCING .....	8-67
SECTION 03 30 00 – CAST-IN-PLACE CONCRETE.....	8-73
<b>DIVISION 9 – FINISHES</b> .....	<b>8-91</b>
SECTION 09 91 23 – PAINTING .....	8-91
<b>DIVISION 23 – HEATING &amp; VENTILATION AND AIR CONDITIONING</b> .....	<b>8-99</b>
SECTION 23 11 26 – FACILITY LIQUEFIED-PETROLEUM GAS PIPING .....	8-99
SECTION 23 13 23 – FACILITY ABOVEGROUND LPG FUEL STORAGE TANKS.....	8-117
<b>DIVISION 26 – ELECTRICAL</b> .....	<b>8-127</b>
SECTION 26 05 19 – LOW-VOLTAGE ELECTRICAL POWER CONDUCTORS AND CABLES .....	8-127
SECTION 26 05 26 – GROUNDING AND BONDING FOR ELECTRICAL SYSTEMS .....	8-131
<b>EXECUTION</b> .....	<b>8-133</b>
SECTION 26 05 29 – HANGERS AND SUPPORTS FOR ELECTRICAL SYSTEMS .....	8-137
SECTION 26 05 33 – RACEWAYS AND BOXES FOR ELECTRICAL SYSTEMS.....	8-143
SECTION 26 05 44 – SLEEVES AND SLEEVE SEALS FOR ELECTRICAL RACEWAYS AND CABLING .....	8-157
SECTION 26 05 53 – IDENTIFICATION FOR ELECTRICAL SYSTEMS .....	8-161
<b>DIVISION 31 – EARTHWORK</b> .....	<b>8-169</b>
SECTION 31 10 00 – SITE CLEARING .....	8-169

*[This Page Intentionally Left Blank]*

**ENGINEER'S SEAL PAGE**

The Technical Specifications contained herein have been prepared by or under the direction of the following Registered Person. Notice to Bidders, Information and Instructions, Bid Submittal Forms, Contract Forms, and Prices, General Conditions and Special Conditions have been prepared by VTA, in conjunction with the Technical Specifications contained herein and the Contract Drawings that are a part of the Contract Documents.

**TECHNICAL SPECIFICATION SECTIONS:**

01 10 00      02 32 19      09 91 23      31 10 00  
01 12 92      02 41 19  
01 31 19      02 80 00  
01 73 00  
01 77 00  
01 78 39



REGISTERED PROFESSIONAL ENGINEER  
KENNETH R. RONSSE, LICENSE NUMBER C51140  
SANTA CLARA VALLEY TRANSPORTATION AUTHORITY

*[This Page Intentionally Left Blank]*

The Technical Specifications contained herein have been prepared by or under the direction of the following Registered Person. Notice to Bidders, Information and Instructions, Bid Submittal Forms, Contract Forms, and Prices, General Conditions and Special Conditions have been prepared by VTA, in conjunction with the Technical Specifications contained herein and the Contract Drawings that are a part of the Contract Documents.

**TECHNICAL SPECIFICATION SECTIONS:**

03 10 00  
03 20 00  
03 30 00

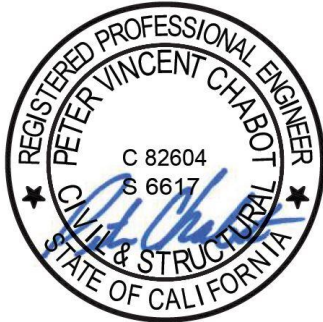

---

REGISTERED PROFESSIONAL ENGINEER  
PETER CHABOT, LICENSE NUMBER C82604 & S6617  
PEOPLES ASSOCIATES STRUCTURAL ENGINEERS

*[This Page Intentionally Left Blank]*



The Technical Specifications contained herein have been prepared by or under the direction of the following Registered Person. Notice to Bidders, Information and Instructions, Bid Submittal Forms, Contract Forms, and Prices, General Conditions and Special Conditions have been prepared by VTA, in conjunction with the Technical Specifications contained herein and the Contract Drawings that are a part of the Contract Documents.

**TECHNICAL SPECIFICATION SECTIONS:**

23 11 26

23 13 23



---

REGISTERED PROFESSIONAL ENGINEER  
LEANNE J. COSSAIRT-LEUNG, LICENSE NUMBER M35365  
INTEGRATED ENGINEERING SERVICES

*[This Page Intentionally Left Blank]*

The Technical Specifications contained herein have been prepared by or under the direction of the following Registered Person. Notice to Bidders, Information and Instructions, Bid Submittal Forms, Contract Forms, and Prices, General Conditions and Special Conditions have been prepared by VTA, in conjunction with the Technical Specifications contained herein and the Contract Drawings that are a part of the Contract Documents.

**TECHNICAL SPECIFICATION SECTIONS:**

26 05 19  
26 05 26  
26 05 29  
26 05 33  
26 05 44  
26 05 53



---

REGISTERED PROFESSIONAL ENGINEER  
Y. B. KUNG, LICENSE NUMBER E11726  
ACKERMAN-PRACTICON CONSOLIDATED TECHNICAL SERVICES

*[This Page Intentionally Left Blank]*

**DIVISION 1 – GENERAL REQUIREMENTS**  
**SECTION 01 10 00 – SUMMARY OF WORK**

**PART 1 – GENERAL**

**1.01 GENERAL PROJECT SUMMARY**

- A. The Work of the Cerone Division Boiler and Propane Tank Replacement Project is described under **Section 1.3 Description of Work** of the Contract Documents.
- B. The Project also includes:
  - 1. Closure, removal, handling, and disposal of Aboveground Storage Tanks (ASTs), boilers, piping, and structures containing hazardous material.
  - 2. Regulatory Compliance:
    - a. Preparation and implementation of Site-Specific Safety Plans.
    - b. Preparation and implementation of Erosion and Sedimentation Control Action Plan (**Appendix G**).
    - c. Preparation and implementation of Hazardous Materials Management Plan (HMMP).
    - d. Obtaining permits from all concerned regulatory entities (including those listed in **Section 6.7 Permits, Fees and Inspections** and **Appendix N**).
    - e. Preparation of pertinent manifests or Bill of Lading for transportation and disposal of hazardous and non-hazardous materials and substances.

**1.02 INTERPRETATION**

- A. These Technical Specifications impose requirements and prohibitions on Contractor. Contractor must interpret these Technical Specifications accordingly, even if no actor or subject is specified in a particular sentence or statement.

**1.03 NOT USED**

**1.04 JOB CONDITIONS**

- A. Refer to **Section 6.11 Work Sequence and Constraints** for requirements pertaining to:
  - 1. Work sequence and constraints
  - 2. Work hours
  - 3. Building access
  - 4. Preservation of refueling access
  - 5. Potholing, trenching, and safety requirements
  - 6. Coordination with other contractors
  - 7. Preservation of utility services, utility interruptions, shutdowns, and cutovers
  - 8. Staging and phasing

- B. Use of Cerone Division: The Worksite area (as identified on the Contract Drawings) will be limited as indicated on the Contract Drawings. Contractor (i) must limit access to these areas to the most direct route from the Cerone Division entrance, (ii) is responsible for restricting the movements of staff, subcontractors, and all associated personnel to the construction limits, and (iii) has no privilege of access beyond the established limits except as permitted for the installation of utilities and services.

#### **1.05 HAZARDOUS MATERIALS**

- A. A limited asbestos, PCBs survey was conducted by Burns McDonnell in preparation for the planned construction, and was issued on November 5, 2018. The survey report is included in **Appendix O** (Hazardous Material Survey Report) of the Contract Documents. Lead containing material was identified on painted surfaces throughout the exterior and interior of the building. Examine report to become aware of hazardous materials impacted by Work shown on the Contract Documents.

#### **1.06 PROJECT MEETINGS**

- A. Pre-Construction and Construction Progress Meetings: Refer to Technical Specifications **Section 01 31 19 – Project Meetings**.
- B. Additional meetings will be scheduled, as necessary, to resolve issues of an immediate or short-term nature that cannot wait until the regularly scheduled Construction Progress Meeting. Although the VTA Resident Inspector has primary responsibility for determining the need for these meetings, Contractor may request a special meeting through the VTA Resident Inspector.

#### **1.07 IDENTIFIED AGENCIES**

- A. Refer to **Section 6.7 Permits, Fees and Inspections**.

#### **1.08 CODES AND STANDARDS**

- A. Conform to provisions of all applicable regulatory requirements and codes. Nothing in the Contract Drawings or Technical Specifications is to be construed to permit Work not conforming to applicable regulatory requirements, codes, and standards.
  - 1. Maintain copies of all codes and regulatory requirements at Worksite during construction.
- B. Should there be any direct conflict between the Contract Drawings and/or Technical Specifications and the regulatory requirements/codes, the regulatory requirements/codes take precedence. However, when materials, workmanship, arrangement or construction indicated in the Technical Specifications and Contract Drawings is of a superior quality or capacity to that required by the regulatory requirements/codes, the Contract Drawings and/or Technical Specifications take precedence. Ruling and interpretations of enforcing agencies are considered to be regulatory requirements.
- C. Any material specified by reference to the number, symbol, or title of a specific standard such as an American National Standard, Industry or Government Code, a trade association code or standard, or other similar standard, shall comply with the requirements in the latest revisions thereof and any amendments or supplements thereto in effect on the date of these Technical Specification. The standards referred to, except as modified in the Technical Specifications, have full force and effect as though printed in these Technical Specifications.

**1.09 SCHEDULING**

- A. Refer to **Section 6.21, Progress Schedule.**

**1.10 QUALITY ASSURANCE PLAN**

- A. Contractor must execute a quality control and quality assurance program. Refer to **Section 6.26 Quality Assurance and Quality Control Requirements**, and **Appendix M Quality Assurance and Quality Control Requirements.**
- B. Contractor's Quality Assurance Plan submittal must include a schedule of tests, inspections, and quality control services called for in these Technical Specifications.

**1.11 SUBMITTALS**

- A. Refer to:
1. **Section 6.6 Contract Data Requirements**
  2. **Section 7.41 Product Options, Supplier Approval and Substitutions**
  3. **Section 7.43 Submittal of Shop Drawings, Product Data and Samples**
  4. **Section 7.49.1 Certificate of Compliance**
  5. **Appendix B Contract Data Requirements**
  6. **Section 8, Technical Specifications**

**PART 2 – PRODUCTS (NOT USED)**

**PART 3 – EXECUTION (NOT USED)**

**END OF SECTION 01 10 00**

*[This Page Intentionally Left Blank]*



## **SECTION 01 12 92 – SCHEDULE OF VALUES**

### **PART 1 – GENERAL**

#### **1.01 SECTION INCLUDES**

- A. Preparation and submittal of Schedule of Values for Lump Sum contracts.

#### **1.02 RELATED SECTIONS**

- A. **Section 6.21 Progress Schedule**
- B. **Section 7.59.1 Schedule of Values**
- C. **Appendix G Environmental Coordination and Cooperation**
- D. **Appendix M Quality Assurance and Quality Control Requirements**

#### **1.03 DEFINITION**

- A. The Schedule of Values is an itemized list furnished by Contractor that establishes the value of each part of the Work for a Lump Sum contract. The Schedule of Values is used as the basis for preparing applications for payments.

#### **1.04 PREPARATION**

- A. The Schedule of Values will correlate directly with the tasks enumerated in Contractor's Baseline schedule.
- B. Costs solely related to the propane storage and distribution system must be segregated in separate line items from costs solely related to the heating hot water and boiler system modifications. Costs for items of work related to both systems must be segregated into other line items for blended items of work.
- C. Use the Technical Specifications table of contents as a guide for listing the value of Work by sections. Arrange the Schedule of Values in tabular form with separate columns to indicate the following for each item listed:
  - 1. Related Technical Specifications Section or Division.
  - 2. Description of Work.
  - 3. Name of subcontractor.
  - 4. Name of manufacturer or fabricator.
  - 5. Name of supplier.
  - 6. Dollar value for labor and materials shown separately for each category, and percentage of the Contract price allocated to each category value.
- D. Temporary facilities and other major cost items that are not direct costs of actual work-in-place may be shown either as separate line items in the Schedule of Values or distributed as general overhead expense, at Contractor's option
- E. Contractor must enumerate all costs associated with the following activities in separate line items of the schedule of values.

1. QA Plan
  - a. QA Plan preparation
    - 1) Include all costs associated with the preparation and implementation of the quality assurance and quality control programs. Refer to **Appendix M**, for **Quality Assurance and Quality Control** (QA/QC) requirements.
  - b. QA Plan monthly reports
    - 1) Include all costs related to complying with the monthly QA/QC reporting requirements of the contract. Divide the total cost up into a monthly quantity equal to the number of months contained in the Contract time of performance.
2. Schedule
  - a. Baseline schedule - preparation and revisions
    - 1) Include all costs associated with the development of the approved baseline schedule. Refer to **Section 6.21 Progress Schedule**, for schedule requirements.
  - b. Monthly schedule updates
    - 1) Include all costs related to complying with the monthly QA/QC reporting requirements of the contract. Divide the total cost up into a monthly quantity equal to the number of months contained in the Contract time of performance.
3. ESCAPE Plan
  - a. ESCAPE Plan preparation
    - 1) Include all labor, equipment, and material costs associated with the preparation of, revision of, and administrative implementation of, the ESCAPE (Erosion and Sediment Control Action Plan Element) Plan. Refer to **Appendix G**, for ESCAPE Plan details.
  - b. ESCAPE Plan initial implementation
    - 1) Include all labor, equipment, and materials costs associated with the initial implementation of the ESCAPE Plan in the field.
  - c. ESCAPE Plan maintenance
    - 1) Include all labor, equipment, and material costs associated with the ongoing monthly maintenance of the field implementation of the ESCAPE Plan.
    - 2) Include all labor, equipment, and material costs related to the ongoing monitoring, reporting, and administration of the ESCAPE Plan.
    - 3) Divide the total maintenance cost up into a monthly quantity equal to the number of months contained in the Contract time of performance.
- F. Provide a separate line item in the Schedule of Values for each part of the Work where invoices submitted by Contractor may include materials or equipment purchased or fabricated and stored but not installed.
  1. Differentiate between items stored on the Worksite and items stored off site.

- G. Each item in the Schedule of Values must be complete. Include total cost and proportionate share of general overhead and profit for each item.
- H. The summation of extensions of quantities and unit prices and related costs must equal the amount of the Lump Sum Contract price indicated in the Bid Form Schedule of Quantities and Prices.

**1.05 SUBMITTAL**

- A. Submittal procedures must be in accordance with the applicable provisions of:
  - 1. **Section 6.6 Contract Data Requirements**
  - 2. **Section 7.41 Product Options, Supplier Approval and Substitutions**
  - 3. **Section 7.43 Submittal of Shop Drawings, Product Data and Samples**
  - 4. **Section 7.49.1 Certificate of Compliance**
  - 5. **Appendix B Contract Data Requirements**
- B. Submit the Schedule of Values in accordance with the requirements of General Conditions **Section 7.59.1 Schedule of Values**.
- C. Submit Schedule of Values no later than 6 Working Days following NOA.
  - 1. A proposed Schedule of Values may be rejected by VTA if any item is determined by VTA to be unbalanced or VTA deems it to be incomplete.
  - 2. VTA may, in its sole discretion, request a detailed cost breakdown of any items. This breakdown will be for the purpose of enabling Contractor and VTA to check and verify the periodic invoices to be submitted by Contractor in connection with request for partial payments.
  - 3. The Schedule of Values will also be used in the calculation of changes, whether additive or deductive, to the extent applicable.
- D. Contractor's submittal of a Schedule of Values acceptable to VTA is one of the prerequisites for issuance of a Notice to Proceed.
- E. Progress payments will be made in accordance with the approved Contractor's Schedule of Values and progress payment protocols set forth in **Section 7.59 Progress Payment**.

**PART 2 – PRODUCTS (NOT USED)**

**PART 3 – EXECUTION (NOT USED)**

**END OF SECTION 01 12 92**

*[This Page Intentionally Left Blank]*

## **SECTION 01 31 19 – PROJECT MEETINGS**

### **PART 1 – GENERAL**

#### **1.01 SECTION INCLUDES**

- A. Requirements for:
  - 1. Pre-construction meeting.
  - 2. Construction progress meetings.
  - 3. Meeting safety and virtual meetings.

#### **1.02 RELATED SECTIONS**

- A. **Section 6.17 Contractor Cooperation and Coordination**
- B. **Section 7.26 Pre-Construction Meeting**
- C. **Section 7.27 Project Meetings**

#### **1.03 PRE-CONSTRUCTION MEETING**

- A. Prior to issuance of the Notice to Proceed, a pre-construction meeting will be held at a time and place to be designated by notice from VTA. The purpose of this meeting is to introduce VTA's Resident Inspector for construction management to their counterparts in Contractor's organization and to establish lines of communication among these representatives. Contractor's Project Manager, superintendent, quality representatives, safety representative, EEO officer and subcontractor representatives must attend. Not less than four working days before the meeting, VTA will distribute a notice of this meeting, along with an agenda of the subjects to be addressed.
- B. Contractor shall perform the following at this pre-construction meeting:
  - 1. Introduce Contractor's representatives and briefly describe each person's responsibilities.
  - 2. Distribute and discuss the list of major subcontractors, their areas of responsibility, sequence of critical work, and tentative schedule of construction.
  - 3. Discuss use of office, storage areas, staging areas, construction areas, and temporary easements.
  - 4. Discuss construction safety.
  - 5. Discuss contractor's approach to infectious disease (COVID-19) safety, including compliance with applicable health orders and industry guidance.
  - 6. Define housekeeping procedures.
  - 7. Discuss construction methods.
  - 8. Discuss quality control/quality assurance.
  - 9. Describe construction sequencing of the entire contract, general jobsite layout, erosion and sedimentation control plans, haul routes, noise abatement, dust abatement, air and

water pollution control, temporary access closings, and pavement restoration, as applicable.

10. Discuss coordination and notifications required for utility work and services.
11. Discuss deliveries and priorities of major equipment.
12. Discuss breakdown of lump sum items.
13. Discuss construction progress schedule.

#### **1.04 CONSTRUCTION PROGRESS MEETINGS**

- A. VTA will schedule construction progress meetings each week, or more often as necessary for the competent and timely execution of the Contract. Contractor's personnel indicated above in Article 1.03, Pre-Construction Meeting, paragraph A must attend these meetings. Contractor will provide a 3-week construction schedule, and Contractor will update this schedule on a weekly basis. Progress meetings must include representatives of subcontractors who are or will be performing work during the next week.
- B. The agenda for construction progress meetings will be prepared by the VTA Resident Inspector with input from Contractor and will include the following:
  1. Introduction of new attendees and areas of responsibility.
  2. Review of minutes of previous meetings, amendment of minutes if necessary, and acceptance of minutes.
  3. Analysis of work accomplished since the previous meeting, offsite fabrication problems, product delivery problems, submitted schedule slippages, problems arising from proposed changes, and other circumstances which might affect progress of the Work. Contractor will create and bring to the progress meeting an updated schedule showing all activities started, completed, and on-going during previous week and such activities scheduled for the next week.
  4. Discussion of sequence of work on the critical path, and schedule of construction using the progress schedule. Each activity must have a current status and forecast completion. Contractor shall report on all activities which are forecasted to be completed beyond the approved schedule date(s) and shall identify means of maintaining the approved schedule.
  5. Discussion of work quality observations, problems, and employee work standards.
  6. Discussion of coordination of utility work, including power shutdowns and cutovers.
  7. Discussion of changed conditions, time extensions, and other relevant subjects as they affect the progress of the Work.
  8. Discussion of corrective measures to maintain construction progress schedule when necessary.
  9. Discussion of potential claims and pending disputed issues.
  10. Inquiries, requests for information, and Change Notices/Change Orders.
  11. Discussion of upcoming month's Work.

**1.05 MEETING SAFETY AND VIRTUAL MEETINGS**

- A. In accordance with required or recommended protocols, and best practices outlined by the Centers for Disease Control and Prevention, the State of California, and the County of Santa Clara Public Health Department, some or all project related meetings may be required to be held online as virtual meetings.
- B. Contractor must provide its staff with equipment, software, online meeting resources, and information technology sufficient to enable full participation in online virtual meetings. Software must be compatible with VTA's existing information technology resources. VTA currently employs the use of Microsoft "Teams" software as its preferred online collaboration and meeting platform. VTA will not provide separate compensation for Contractor's use of Microsoft Teams. Other online collaboration and meeting platforms may be acceptable.
  - 1. If Contractor elects to utilize software or technology incompatible with VTA's available technology (or currently unlicensed by / unavailable to VTA), Contractor must provide VTA staff with hardware (and/or software licensing) sufficient to enable VTA staff to meet with Contractor staff virtually using Contractor's chosen meeting platform, all at no additional cost to VTA.
- C. Online virtual meetings must be configured and initiated in a secure manner that does not compromise the integrity and security of VTA information technology resources. VTA reserves the right to reject the use of Contractor's chosen online meeting platform if there are documented information technology security concerns.

**PART 2 – PRODUCTS (NOT USED)**

**PART 3 – EXECUTION (NOT USED)**

**END OF SECTION 01 31 19**

*[This Page Intentionally Left Blank]*



## **SECTION 01 73 00 – EXECUTION**

### **PART 1 – GENERAL**

#### **1.01 SECTION INCLUDES**

- A. General administrative and procedural requirements governing execution of the Work including, but not limited to:
  - 1. Construction layout
  - 2. Utility Work
  - 3. Installation of the Work
  - 4. Cutting and patching
  - 5. Open trench safety and traffic control
  - 6. Progress cleaning
  - 7. Starting and adjusting
  - 8. Protection of installed construction
  - 9. Field welding & hot work

#### **1.02 RELATED SECTIONS**

- A. **Section 6.11 Work Sequence and Constraints**
- B. **Technical Specifications Section 02 32 19 – Potholing**
- C. **Technical Specifications Section 02 41 19 – Selective Demolition**
- D. **Division 23 and Division 26** of the Technical Specifications:
  - 1. These sections contain specific requirements on the extent and limitations applicable to demolition, cutting and patching, or altering existing construction applicable to fueling, mechanical, and electrical installations.

#### **1.03 DEFINITIONS**

- A. **Cutting:** Removal of in-place construction necessary to permit installation or performance of subsequent work.
- B. **Patching:** Fitting and repair work required to restore construction to original conditions after installation of subsequent work.

#### **1.04 SAFETY REQUIREMENTS**

- A. **General:** Maintain neat, orderly, and hazard-free on-site operations in conformance with CAL OSHA requirements until final acceptance of the Work.

#### **1.05 QUALITY ASSURANCE**

- A. **Cutting and Patching:** Comply with requirements for and limitations on cutting and patching of construction elements.

1. Do not cut and patch construction elements or components in a manner that could change their load-carrying capacity, that results in reducing their capacity to perform as intended, or that results in increased maintenance or decreased operational life or safety.
2. Visual Elements: Do not cut and patch construction in a manner that results in visual evidence of cutting and patching. Remove and replace construction that has been cut and patched in a visually unsatisfactory manner.

#### **1.06 PROJECT CONDITIONS**

- A. Maintain access to existing walkways and other adjacent occupied or used facilities.
  1. Do not close or obstruct walkways or other occupied or used facilities without written permission from VTA.
- B. Utility Service: Maintain existing utilities indicated to remain in service and protect them against damage during selective demolition operations.

#### **1.07 SUBMITTALS**

- A. Submittal procedures must be in accordance with the applicable provisions of:
  1. **Section 6.6 Contract Data Requirements**
  2. **Section 7.41 Product Options, Supplier Approval and Substitutions**
  3. **Section 7.43 Submittal of Shop Drawings, Product Data and Samples**
  4. **Section 7.49.1 Certificate of Compliance**
  5. **Appendix B Contract Data Requirements**
- B. Submit product data for materials proposed for use in patching.
  1. Where patching materials affect aesthetic qualities of the finished work and are required to visually match in-place adjacent surfaces, provide physical samples to demonstrate accurate appearance.
- C. Submit Traffic and Pedestrian Control Plans.
  1. Illustrate stages and sequence of work to provide a clear understanding of impacts to vehicular and pedestrian impacts.
  2. Indicate the extent of trenched areas that must be protected at any given time, including the method of protection provided. Identify specific devices / equipment to be used.
- D. Submit utility bypass / relocation plans.
  1. For any utilities required to be relocated or bypassed in order to prosecute the Work, submit a utility bypass / relocation plan describing:
    - a. Exact extents of the relocation or bypass,
    - b. Expected utility outage or interruption duration(s),
    - c. Affected equipment or users,
    - d. Proposed shutdown / de-energization procedures,
    - e. Restart procedures.

## **PART 2 – PRODUCTS**

### **2.01 MATERIALS**

- A. In-Place Materials: Use materials for patching identical to in-place materials. For exposed surfaces, use materials that visually match in-place adjacent surfaces to the fullest extent possible.
  - 1. If identical materials are unavailable or cannot be used, use materials that, when installed, will provide a match acceptable to VTA for the visual and functional performance of in-place materials.

## **PART 3 – EXECUTION**

### **3.01 EXAMINATION**

- A. Examination and Acceptance of Conditions: Before proceeding with each component of the Work, examine substrates, areas, and conditions for compliance with requirements for installation tolerances and other conditions affecting performance.
  - 1. Examine roughing-in for mechanical and electrical systems to verify actual locations of connections before equipment and fixture installation.
  - 2. Examine for suitable conditions where products and systems are to be installed.
  - 3. Verify compatibility with and suitability of substrates, including compatibility with existing finishes.

### **3.02 PREPARATION**

- A. Field Measurements: Take field measurements as required to fit the Work properly. Recheck measurements before installing each product. Where portions of the Work are indicated to fit to other construction, verify dimensions of other construction by field measurements before fabrication.
- B. Fabrication: Coordinate fabrication schedule with construction progress to avoid delaying the Work.
- C. Space Requirements: Verify space requirements and dimensions of items shown diagrammatically on Contract Drawings.

### **3.03 CONSTRUCTION LAYOUT**

- A. Verification: Before proceeding to lay out the Work, verify layout information shown on Contract Drawings.
- B. Site Improvements: Locate and lay out site improvements, including pavements, grading, fill and topsoil placement, utility slopes, and rim and invert elevations.

### **3.04 UTILITY SERVICES**

- A. Do not cut, remove, relocate, or abandon existing site or building utilities, until provisions have been made to bypass them.
  - 1. Provide temporary utilities that bypass area of selective demolition and that maintain continuity of service to affected areas of the site and buildings.

2. There must be no unplanned utility interruptions and shutdowns.
  3. Submit a utility bypass / relocation plan a minimum of 30 days in advance of any proposed utility shutdown or interruption.
- B. Do not disable a fire protection system (sprinklers, fire alarm system components, etc.) unless prior approval has been provided in writing by VTA.
1. If a system is disabled, contractor must provide fire watch personnel until that system is reconnected or other arrangements have been made and approved by VTA.
- C. Contractor will be held responsible for any damage done to any utility in the performance of Work.
- D. If it becomes necessary to repair, reconstruct, or relocate existing utilities within the Contract Worksite, all such work must be accomplished at no additional cost to VTA.
1. Existing utilities encountered but not identified on plans, or in utility location information provided by VTA, will be considered outside of base Contract scope.
    - a. Existing utility information provided in **Appendix R** was compiled from various time periods. Contractor must assume that all utilities are present and anticipate potholing requirements accordingly.

### **3.05 INSTALLATION**

- A. General: Locate the Work and components of the Work accurately, in correct alignment and elevation, as indicated.
1. Make vertical work plumb and make horizontal work level.
  2. Where space is limited, install components to maximize space available for maintenance and ease of removal for replacement.
- B. Comply with manufacturer's written instructions and recommendations for installing products in applications indicated.
- C. Install products at the time and under conditions that will ensure the best possible results. Maintain conditions required for product performance until Substantial Completion.
- D. Conduct construction operations so no part of the Work is subjected to damaging operations or loading in excess of that expected during normal conditions of occupancy.
- E. Sequence the Work and allow adequate clearances to accommodate movement of construction items on site and placement in permanent locations.
- F. Tools and Equipment: Where possible, select tools or equipment that minimize production of excessive noise levels.
- G. Templates: Obtain and distribute to the parties involved templates for Work specified to be factory prepared and field installed.
1. Check shop drawings of other portions of the Work to confirm that adequate provisions are made for locating and installing products to comply with indicated requirements.

- H. Attachment: Provide blocking and attachment plates and anchors and fasteners of adequate size and number to securely anchor each component in place, accurately located and aligned with other portions of the Work.
  - 1. Where size and type of attachments are not indicated, verify size and type required for load conditions.
- I. Mounting Heights: Where mounting heights are not indicated, mount components at heights directed by VTA.
- J. Allow for movement, including thermal expansion and contraction.
- K. Coordinate installation of anchorages. Furnish setting drawings, templates, and directions for installing anchorages, including sleeves, concrete inserts, anchor bolts, and items with integral anchors, that are to be embedded in concrete or masonry.
- L. Joints: Make joints of uniform width. Where joint locations in exposed work are not indicated, arrange joints as directed by VTA. Fit exposed connections together to form hairline joints.
- M. Repair or remove and replace damaged, defective, or nonconforming Work.

### **3.06 CUTTING AND PATCHING**

- A. Perform cutting and patching for the following:
  - 1. Cutting and patching existing construction altered or disturbed to accommodate new construction.
  - 2. Cutting and patching existing construction damaged or defaced during new construction.
  - 3. Cutting and patching required to install or correct non-coordinated Work.
  - 4. Cutting and patching required to remove and replace defective and non-conforming Work.
  - 5. Cutting and patching required to uncover work to inspect hidden conditions.
  - 6. Cutting and patching required to repair independent testing agency methods and operations.
  - 7. Any other cutting and patching not yet performed as part of the Work specified in other Technical Specifications sections.
- B. Employ skilled workers to perform cutting and patching. Proceed with cutting and patching at the earliest feasible time and complete without delay.
  - 1. Cut in-place construction to provide for installation of other components or performance of other construction, and subsequently patch as required to restore surfaces to their original condition.
  - 2. Temporary Support: Provide temporary support of Work to be cut.
  - 3. Protection: Protect in-place construction during cutting and patching to prevent damage. Provide protection from adverse weather conditions for portions of Work that might be exposed during cutting and patching operations.

4. Existing Utility Services and Mechanical/Electrical Systems: Where existing services/systems are required to be removed, relocated, or abandoned, bypass such services/systems before cutting to prevent interruption to occupied areas.
- C. Cutting: Cut in-place construction by sawing, drilling, breaking, chipping, grinding, and similar operations, including excavation, using methods least likely to damage elements retained or adjoining construction.
1. In general, use hand or small power tools designed for sawing and grinding, not hammering and chopping. Cut holes and slots neatly to minimum size required, and with minimum disturbance of adjacent surfaces. Temporarily cover openings when not in use.
  2. Finished Surfaces: Cut or drill from the exposed or finished side into concealed surfaces.
  3. Concrete and Masonry: Cut using a cutting machine, such as an abrasive saw or a diamond-core drill.
  4. Excavating and Backfilling: Comply with requirements set forth in the Contract Documents where excavating and backfilling is required by cutting and patching operations.
  5. Mechanical and Electrical Services: Cut off pipe or conduit in walls or partitions to be removed. Cap, valve, or plug and seal remaining portion of pipe or conduit to prevent entrance of moisture or other foreign matter after cutting.
- D. Patching: Patch construction by filling, repairing, refinishing, closing up, and similar operations following performance of other work. Patch with durable seams that are as invisible as practicable. Provide materials and comply with installation requirements specified in the Contract Documents, where applicable.
1. Inspection: Where feasible, test and inspect patched areas after completion to demonstrate physical integrity of installation.
  2. Exposed Finishes: Restore exposed finishes of patched areas and extend finish restoration into retained adjoining construction in a manner that will minimize evidence of patching and refinishing.
  3. Clean piping, conduit, and similar features before applying paint or other finishing materials.
  4. Restore damaged pipe covering to its original condition.
  5. Existing bolts, anchors and fastenings embedded in concrete that are used to support the removed items shall be removed to a depth of at least one inch below the finish surface. The resulting holes must be filled with repair mortar.
  6. Where walls or partitions that are removed extend one finished area into another, patch and repair floor and wall surfaces in the new space. Provide an even surface of uniform finish, color, texture, and appearance. Remove in-place floor and wall coverings and replace with new materials, if necessary, to achieve uniform color and appearance.
  7. Where patching occurs in a painted surface, prepare substrate and apply primer and intermediate paint coats appropriate for substrate over the patch, and apply final paint

coat over entire unbroken surface containing the patch. Provide additional coats until patch blends with adjacent surfaces.

8. Patching at Lead-Containing Paint Locations (LCP): Stabilize LCP locations by removing loose and flaking paint. Prepare surface for repainting by applying an encapsulation coating (specifically made for application over lead-based paint) to the area.
- E. Penetrations at Fire-Rated Construction: Seal all penetrations of fire rated walls and partitions using firestopping and smoke seal material in compliance with an applicable Underwriter's Laboratory listed assembly, to full thickness of the penetrated elements.
- F. Cleaning: Clean areas and spaces where cutting and patching are performed. Remove paint, mortar, oils, putty, and similar materials from adjacent finished surfaces.

### **3.07 TRAFFIC CONTROL AND BARRIERS FOR CONSTRUCTION**

- A. Traffic control and barriers for construction must include the provisions for protecting pedestrian and vehicular traffic in the yard during the work and non-work hours, and for protection of open trenches during construction.
- B. At the end of each work day, all excavations resulting in open trenches of the sidewalk, driveway, or other areas of the bus right of way require steel plate bridging. Areas other than sidewalk, driveway or bus right of way shall be securely covered by steel plate, plywood covering, fenced off, or secured by other means to protect the Worksite, and sufficient to prevent injury to VTA staff or other contractors.
- C. Steel plates must be flush or transitioned with the sidewalk, driveway, or bus right of way. Whenever the grade difference between the existing pavement and the excavated area is greater than  $\frac{3}{4}$  inch, provide a transitioned surface using hot-patched asphalt concrete.
- D. Trip hazards or other safety hazards shall be protected at the end of each work day to prevent injury to VTA staff or other contractors.

### **3.08 PROGRESS CLEANING**

- A. General: Clean Worksite daily, including common areas. Enforce requirements strictly. Dispose of materials lawfully.
  1. Containerize hazardous and unsanitary waste materials separately from other waste. Mark containers appropriately and dispose of legally, according to all applicable laws, regulations, and rules.
    - a. Use containers intended for holding waste materials of type to be stored.
  2. Coordinate progress cleaning for joint-use areas where Contractor and other contractors are working concurrently.
  3. Contain dust and wastes, and provide frequent cleaning, to prevent safety hazards, and to prevent nuisance conditions that could impair VTA operations.
- B. Site: Maintain Worksite free of waste materials and debris.
- C. Work Areas: Clean areas where Work is in progress to the level of cleanliness necessary for proper execution of the Work.
  1. Remove liquid spills promptly.

2. Where dust would impair proper execution of the Work, broom-clean or vacuum the entire work area, as appropriate.
- D. Installed Work: Keep installed work clean. Clean installed surfaces according to written instructions of manufacturer or fabricator of product installed, using only cleaning materials / products specifically recommended. If no specific cleaning materials / products are recommended, use cleaning materials / products that are not hazardous to health or property and that will not damage exposed surfaces.
- E. Concealed Spaces: Remove debris from concealed spaces before enclosing the space.
- F. Exposed Surfaces in Finished Areas: Clean exposed surfaces and protect as necessary to ensure freedom from damage and deterioration at time of Substantial Completion.
- G. Waste Disposal: Do not bury or burn waste materials on-site. Do not wash waste materials down sewers or into waterways. Do not disperse waste liquids on site, properly dispose of waste liquids according to type.
- H. During handling and installation, clean and protect construction in progress and adjoining materials already in place. Apply protective covering where required to ensure protection from damage or deterioration at Substantial Completion.
- I. Clean and provide maintenance on completed construction as frequently as necessary through the remainder of the construction period. Adjust and lubricate operable components to ensure operability without damaging effects.

### **3.09 STARTING AND ADJUSTING**

- A. Coordinate startup and adjusting of equipment and operating components with requirements in:
  1. Technical Specifications **Section 23 13 23 – Facility Aboveground LPG Storage Tank**
  2. Technical Specifications **Section 23 52 16 – Condensing Boilers**
- B. Start equipment and operating components to confirm proper operation. Remove malfunctioning units, replace with new units, and retest.
- C. Adjust equipment for proper operation. Adjust operating components for proper operation without binding.
- D. Test each piece of equipment to verify proper operation. Test and adjust controls and safeties. Replace damaged and malfunctioning controls and equipment.

### **3.10 PROTECTION OF INSTALLED CONSTRUCTION**

- A. Provide final protection and maintain conditions that ensure installed Work is without damage or deterioration at time of Substantial Completion.
- B. Protection of Existing Items: Provide protection and ensure that existing items to remain undisturbed by construction are maintained in condition that existed at commencement of the Work.
- C. Comply with manufacturer's written instructions for temperature and relative humidity.



**3.11 FIELD WELDING AND HOT WORK**

- A. Contractor may not conduct any field welding (including exothermic welding) onsite without prior written approval of VTA. Request approval a minimum of 14 days in advance.
- B. Contractor must prepare hot work permits for any hot work desired to be conducted on site. Hot work permitting process must be in conformance with NFPA 51B.

**END OF SECTION 01 73 00**

*[This Page Intentionally Left Blank]*

## **SECTION 01 77 00 – CLOSEOUT PROCEDURES**

### **PART 1 – GENERAL**

#### **1.01 SECTION INCLUDES**

- A. Requirements preparatory to final inspection.
- B. Final inspection.
- C. Acceptance of the Work and final payment.

#### **1.02 RELATED SECTIONS**

- A. **Section 6.18 Substantial Completion and Acceptance**
- B. **Section 6.20 Project Close-Out Requirements – Record Drawings**
- C. **Section 7.55 Final Inspection and Acceptance of All or a Portion of the Work**
- D. **Section 7.62 Final Payment**
- E. **Technical Specifications Section 01 78 39 – Project Record Documents**

#### **1.03 SUBMITTALS**

- A. Submittal procedures must be in accordance with the applicable provisions of:
  - 1. **Section 6.6 Contract Data Requirements**
  - 2. **Section 7.41 Product Options, Supplier Approval and Substitutions**
  - 3. **Section 7.43 Submittal of Shop Drawings, Product Data and Samples**
  - 4. **Section 7.49.1 Certificate of Compliance**
  - 5. **Appendix B Contract Data Requirements**
- B. Contractor's Substantial Completion Preliminary Punch List
- C. Startup Testing / Adjusting / Balancing records and test reports
- D. Record Documents
- E. Written Request for Substantial Completion Inspection
- F. Certified Copy of Substantial Completion Punch List
- G. Written Request for Final Completion Inspection

#### **1.04 SUBSTANTIAL COMPLETION**

- A. Preliminary Procedures: Before requesting inspection for determining date of Substantial Completion, complete the following:
  - 1. Prepare a list of items to be completed and corrected (punch list). Include the value of items on the list, and reasons why the Work is not complete.
  - 2. Provide VTA written notice at least seven calendar days in advance of the requested date of inspection.

3. VTA will perform the inspection within three days of the requested date.
4. Prior to the requested date of inspection, Contractor must perform or provide the following, as applicable:
  - a. Remove from the Worksite all temporary facilities, except as may be required for punch list work.
  - b. Complete startup testing of systems.
  - c. Submit test/adjust/balance records.
  - d. Complete, sign and submit to VTA record drawings and specifications, record shop drawings, record permits, warranties, and operations and maintenance manuals.
  - e. Complete final cleaning of all areas not affected by punch list work. Conduct cleaning and waste removal operations to comply with local laws and ordinances and Federal and local environmental regulations.
  - f. Complete touchup painting, and otherwise repair and restore marred exposed finishes to eliminate visual defects.
- B. Inspection: Submit a written request for inspection for Substantial Completion. On receipt of request, VTA will either proceed with inspection or notify Contractor of unfulfilled requirements. VTA will prepare the Certificate of Substantial Completion after inspection or will notify Contractor of items, either on Contractor's list or additional items identified by VTA, that must be completed or corrected before certificate will be issued.
  1. Reinspection: Request reinspection when the Work is identified in previous inspections as incomplete is completed or corrected.
  2. Results of completed inspection will form the basis of requirements for final completion.
  3. Contractor shall be represented during the inspection by its principal superintendent and such subcontractors and suppliers as may be necessary to answer the questions of the VTA inspection team.

#### **1.05 FINAL COMPLETION**

- A. Preliminary Procedures: Before requesting final inspection for determining date of final completion, complete the following:
  1. The certified copy of the list shall state that each item has been completed or otherwise resolved for acceptance.
- B. Submit certified copy of VTA's Substantial Completion inspection list of items to be completed or corrected (punch list), endorsed and dated by VTA.
  1. The certified copy of the list shall state that each item has been completed or otherwise resolved for acceptance.
- C. Inspection: Submit request for final inspection for acceptance.
  1. The request must be made in writing, addressed to VTA, at least seven calendar days in advance of the requested date of the final inspection.
- D. The date of final completion will establish the completion date of the Work, for determining liquidated damages.

**1.06 ACCEPTANCE OF THE WORK AND FINAL PAYMENT**

- A. Final completion and acceptance of the Work will be made in accordance with **Section 7.55 Final Inspection and Acceptance of All or a Portion of the Work**. Final payment will be made in accordance with **Section 7.62 Final Payment**.

**PART 2 – PRODUCTS (NOT USED)**

**PART 3 – EXECUTION (NOT USED)**

**END OF SECTION 01 77 00**

*[This Page Intentionally Left Blank]*

## **SECTION 01 78 39 – PROJECT RECORD DOCUMENTS**

### **PART 1 – GENERAL**

#### **1.01 SECTION INCLUDES**

- A. Annotating, maintaining, and delivering project record documents.
- B. Project photographic documentation and surveys.
- C. Construction document management system.

#### **1.02 RELATED SECTIONS**

- A. **Section 6.20 Project Close-Out Requirements – Record Drawings**
- B. **Section 7.54 Redlined Construction Drawings**
- C. **Section 7.73 Warranty**

#### **1.03 SUBMITTALS**

- A. Submittal procedures must be in accordance with the applicable provisions of:
  - 1. **Section 6.6 Contract Data Requirements**
  - 2. **Section 7.41 Product Options, Supplier Approval and Substitutions**
  - 3. **Section 7.43 Submittal of Shop Drawings, Product Data and Samples**
  - 4. **Section 7.49.1 Certificate of Compliance**
  - 5. **Appendix B Contract Data Requirements**
- B. Construction document management system:
  - 1. Document management system accounts – provide two accounts.
  - 2. Document management system field equipment – provide two devices.
- C. Red-lined conformed Contract Documents – Volume 1 – three hard copy sets.
- D. Red-lined Contract Documents – Volume 2 (“Contract Drawings”) – three half-size hard copy sets.
- E. Record red-lined shop drawings – three half-size hard copy sets.
- F. Operation and maintenance manuals – three hard copy sets.
- G. Warranties – three hard copy sets.
- H. Regulatory applications and permits – three hard copy sets.
- I. Test and inspection reports – three hard copy sets
- J. Pre-construction site photos
  - 1. Pre-construction copy – submit prior to commencing construction activities in the field, and no later than seven days after issuance of NTP.
  - 2. Record copy - submit electronically on the record document USB storage drives.

- K. Construction progress photos (including project completion photos) – submit electronically on the record document USB storage drives.
- L. Electronic record document submittals:
  - 1. Submit four separate record document USB storage drives, each containing the following:
    - a. PDF electronic versions of all documents listed above (A through G).
    - b. Pre-construction site photos – in jpeg file format (item “H” listed above).
    - c. Construction progress photos – in jpeg file format (item “I” listed above).
    - d. Export of all information from the construction document management system.
    - e. Serial numbers catalog spreadsheet in PDF and native file format (Microsoft Excel, etc.).

## **PART 2 – PRODUCTS**

### **2.01 DOCUMENTS**

- A. Red-lines
  - 1. Red-line marking must be bold and clearly distinguishable from on original text and linework.
  - 2. All pages of hard copy reproductions must be clear and legible. Colored marking and pages must be reproduced in full color.
- B. Electronic PDF versions of documents
  - 1. PDF versions of documents must be generated from native file format electronic files where available.
  - 2. PDF versions of documents generated by scanning of a hard copy must be scanned in color (when the hardcopy contains color) and be of sufficient resolution and quality as to be clearly legible.
    - a. PDF’s generated by scanning must analyzed and saved with Optical Character Recognition (OCR), or be scanned at a resolution and quality setting such that later OCR analysis will provide reliable text recognition.
- C. USB storage drives
  - 1. USB devices should be of sufficient capacity as to contain one entire set of the requested documents on one device. If multiple devices are necessary to contain one complete set, the individual devices must each be clearly indexed and labeled to indicate the volume number and total number of volumes in that set.
    - a. Minimum USB device capacity must be 128 GB or greater.
    - b. Minimum transfer speed rating of USB 3.0 or greater.
  - 2. USB devices must all be identical in make & model number.
  - 3. USB devices must be of a quality suitable for archival use. Acceptable manufacturers are: Sandisk, Lexar, or Sony.



D. Construction document management system

1. Contractor must provide and implement an electronic construction document management system. Contractor's key personnel must employ the system to ensure field crews are working from the latest approved construction documents and can record field changes and concerns in real time.
  - a. Construction document management system must be capable of:
    - 1) Storing drawings, technical specifications, shop drawings, and related documents associated with the project in a secure, central, cloud-based repository. Documents must be accessible offline, but users prompted automatically for updates whenever online.
    - 2) Revision control of drawings, storing multiple revisions of drawings with the ability to review prior revisions.
      - a) When new drawings, or revisions to existing drawings, are entered into the system, the system must automatically prompt users to download updated information, such that all users are always utilizing the most current version of documents.
    - 3) System must allow for scaling and measurement off drawings to determine dimensions not explicitly stated.
    - 4) System must allow for drawings to be marked up and annotated with comments or field red-lined changes.
    - 5) System must allow for drawings to be appended with photos to illustrate construction issues as they relate to the design indicated on the pertinent drawing(s).
    - 6) System must be capable of export of all documents and information at the conclusion of the project, including markups and annotations. Information must be exportable in a format that all information is usable without the use of further subscription to the construction document management system.
    - 7) Construction document management system must be PlanGrid by Autodesk, or equivalent.
2. Contractor must provide accounts and equipment for VTA's project engineer and resident inspector to use. The accounts and equipment will become the property of VTA at the conclusion of the project.
  - a. Accounts: Provide two construction document management system accounts for VTA use. Accounts must allow unrestricted use of at least 100 drawing sheets at a time. Contractor must prepay all account subscription fees for at least a two-year period. Coordinate with VTA for establishment of accounts and usernames.
  - b. Equipment: Provide two sets of tablets (or two-in-one style laptops) for VTA use.
    - 1) Minimum 12" or greater size touchscreen, compatible with active stylus.
    - 2) Wi-Fi enabled, 256 GB or greater of solid-state storage capacity.

- 3) Provide active stylus and attached (or detachable) keyboard (of same brand as device) designed specifically for use with the model tablet (or two-in-one) provided.
- 4) Provide impact resistant ruggedized hardcase designed for specific model of device provided (Urban Armor Gear, OtterBox, or equivalent).
- 5) Provide extended warranty / accidental damage coverage plan (Microsoft Complete, AppleCare+, or equivalent) for devices provided
- 6) Equipment must be latest model (at the time of bid) Microsoft Surface Pro, Apple iPad Pro, or equivalent.

### **PART 3 – EXECUTION**

#### **3.01 MAINTENANCE OF DOCUMENTS**

- A. Store the project record documents during construction, at Contractor’s field office. File record documents separate from other documents. Maintain in a clear and legible condition.
- B. Do not use project record documents for “in the field” construction purposes.
- C. Make project record documents available for auditing by VTA or any other authorities having jurisdiction.

#### **3.02 CONSTRUCTION DOCUMENT MANAGEMENT SYSTEM**

- A. Contractor must utilize the construction document management system to catalog and track changes made to contract conditions, Contract Drawings, technical specifications, shop drawings, field memos, and RFI’s. Utilize the system to provide field staff with the latest approved construction information and ensure that field crews are always utilizing the most current information. Track all field changes made by marking up or annotating the documents in the construction document management system.
  1. Upload of new information must be timely. Upload new information as soon as possible, but no later than two business days from Contractor’s receipt of approved documents.
- B. Record changes electronically in a manner consistent with the requirements for recording changes on hard copy documents as contained in subsection 3.03 – Project Record Documents.
- C. Record field changes and any deviations from information contained on the design documents, shop drawings, or other approved documents such as change orders, field memos, or RFI’s.
- D. Document the as-built condition by markups, annotations, or appended photographs. Note discrepancies and indicate dimensions so that items of Work can be located precisely, even when later concealed by subsequent Work.
  1. Underground structures:
    - a. New construction: Document the precise as-built depth and horizontal location of all Contractor installed underground structures, conduits, and piping. For linear utilities, document installed depth at 5’ or less intervals. For joint utility trenches, separately

- record and indicate the depth and horizontal location of each utility (gas, electrical, etc.).
- b. Existing construction: Where Contractor installed underground utilities or structures encounter existing underground utilities, or where existing utilities are locating by Contractor's potholing and locating efforts, precisely record the horizontal location and depth of the existing utility, whether shown on existing Contract Drawings or not.
2. Removed facilities:
- a. Where existing facilities are removed, indicate the precise as-built limits of removal.
  - b. For items removed in entity, note the date of removal. Note any appurtenances or anchorages that are left to remain.
  - c. For items partially removed, note the date of removal, and the precise start and ending point of the removal. For segments removed more than 30 days apart of each other, note the individual segment dates of removal.
  - d. For items abandoned in place, note the precise limits of removal and the locations abandoned in place. Note the method by which the segment abandoned in place was deenergized or inerted, and the disposition of the item (slurry filled, sand filled, capped, etc.).
- E. Document construction issues and concerns. Utilize the ability to append drawings with photographs and comments to document construction issues and to aid in the formation of Contractor inquiries or RFI's.
- F. Export of final documents:
- 1. At the conclusion of the project, Contractor must export all documents from the construction document management system and save the information to the record document storage drives.
  - 2. Information must be exported and saved in a format such that all information is usable offline without maintaining a subscription to the construction management system accounts. Coordinate with VTA for acceptable formatting and categorization of information. PDF formatting is preferred. Multiple copies of the information may be required to be saved in segregated folders in order to preserve the revision history and to properly view the different layers of annotations and attachments within their related context.
  - 3. Contractor must preserve the information in, and the use of, the cloud based construction document management system until VTA has accepted the format and content of the final construction management system document export.

### **3.03 PROJECT RECORD DOCUMENTS**

- A. General:
- 1. Legibly record the changes concurrent with the construction progress on at least a weekly basis. Do not conceal the Work until the changes have been recorded.

- a. In the event that project record documents are not updated, VTA may withhold all or part of Contractor's progress billing until the contract record documents are updated to the satisfaction of VTA.
  2. Conformed Contract Documents – Volume 1:
    - a. Annotate the cover of the Conformed Contract Documents – Volume 1 with “PROJECT RECORD DOCUMENT”, in ½-inch high printed letters.
    - b. Annotate each page with “PROJECT RECORD DOCUMENT” as a header centered at the top of the page, in ¼-inch high printed letters.
      - 1) Contractor may propose alternate means of electronic copy annotation, provided any alternatives will be subject to VTA approval and must accomplish the same intent of clearly denoting all pages as record document versions .
  3. Conformed Contract Documents – Volume 2 (“Contract Drawings”):
    - a. Annotate each page of the Contract Drawings with "PROJECT RECORD DRAWING", in ½-inch high printed letters.
    - b. Indicate a new entry in the revision block that reads "PROJECT RECORD DRAWING". The revision shall be initialed and dated by Contractor's representative.
- B. Conformed Contract Documents – Volume 1:
1. Technical Specifications: Legibly annotate each Section of the Technical Specifications to indicate the actual product installation where installation varies from that indicated in the Technical Specifications.
    - a. Identify proprietary name and model number of products, materials, and equipment actually installed, including substitutions and product options.
    - b. Note RFI numbers and Change Notice and Change Order numbers, where applicable. Such reference to RFI numbers and Change Notice and Change Order numbers will not be accepted as the sole description of the change. All changes must be shown completely.
  2. Give particular attention to information on concealed products and installations that cannot be readily identified and recorded later.
- C. Conformed Contract Documents – Volume 2 (“Contract Drawings”):
1. Maintain a set of annotated Contract Drawings to show the actual installation where installation varies from that shown originally. Hard copy versions maintained for this purpose must be full size (22" x 34") sets. Electronic drawing sets maintained for this purpose shall be of sufficient resolution such that the clarity of the original Contract Drawings and all annotations meet or exceed the clarity that would have been provided by annotations on full size (22" x 34") hard copy versions. Where more than one change is made in any area of the Contract Drawings, clearly identify the sequence(s) of changes graphically. As necessary, provide overlays or make legible duplications of the same drawing(s) showing preceding changes, as necessary to properly document the chronology of changes. Overlays and or new reproducible must be inserted in a manner that precludes losing or damaging the documents.

2. Mark the Contract Drawings to show the horizontal location, elevation / depth, and dimensions of each underground or otherwise concealed structure, utility, subsurface obstruction, and appurtenance not shown on the Contract Drawings, or the elevations and dimensions which vary from those indicated. Reference locations and elevations to permanent surface features.
3. Annotate the Contract Drawings or shop drawings, whichever is most capable of showing actual physical conditions, completely and accurately. Where shop drawings are marked, show cross-reference on the Contract Drawings.
4. Annotate in red. Use other colors to distinguish between changes for different categories of the Work at the same location.
5. Annotate important additional information that was either shown schematically or omitted from original Contract Drawings.
6. Mark RFI numbers and Change Notice and Change Order numbers, where applicable. Such reference to RFI numbers and Change Notice and Change Order numbers will not be accepted as sole description of the change. All changes shall be shown completely.
7. Clearly indicate all changes by a "cloud" drawn around the area or areas affected.
8. Prepare new record drawings where VTA determines that neither the original Contract Drawings nor shop drawings are suitable to show actual installation.
  - a. Drawing information must fit in the standard drawing size for the project 22" x 34", which includes the border frame of the drawing.
  - b. The project title, Contract number, and date for drawing revision must appear on the drawing.

### **3.04 OPERATIONS AND MAINTENANCE MANUALS**

- A. General: Assemble a complete set of operation and maintenance data indicating the operation and maintenance of each system, subsystem, and piece of equipment not part of a system. Include operation and maintenance data required in individual Technical Specification sections, and as follows:
  1. Operation Data:
    - a. Emergency instructions and procedures.
    - b. System, subsystem, and equipment descriptions, including operating standards.
    - c. Operating procedures, including startup and shutdown operations.
    - d. Description of controls and sequence of operations.
    - e. Piping and wiring diagrams.
  2. Maintenance Data:
    - a. Manufacturer's information, including list of spare parts.
    - b. Name, address, and telephone number of Installer or supplier.
    - c. Maintenance procedures, including maintenance and service schedules for preventive and routine maintenance.

- d. Maintenance record forms.
  - e. Sources of spare parts and maintenance materials.
  - f. Copies of warranties.
3. Regulatory Permits:
- a. Permit applications.
  - b. Permits.
  - c. Permit inspection reports and correction lists.
4. Drawings:
- a. Shop drawings, including mechanical schematics, piping and wiring diagrams, connection diagrams.
5. Serial Numbers:
- a. SERIAL NUMBERS of all installed equipment must be cataloged in an electronic spreadsheet format and included with the Operation and Maintenance manuals.
    - 1) A copy of the serial numbers spreadsheet must be included on the record document USB storage drives, in PDF and native file format (Microsoft Excel, etc.).
- B. Prepare data in the form of an instructional manual that satisfies the following requirements:
1. Binders: Commercial quality, 8-1/2" x 11' three-ring binders with hardback, cleanable, vinyl covers, thickness necessary to accommodate contents, with pocket inside the covers to receive folded oversized sheets.
  2. Cover: Identify each binder on front and spine with typed or printed title OPERATION AND MAINTENANCE MANUAL, project name, contractor information (name, address, telephone number).
  3. Inside Cover: Provide complete table of contents.
  4. Tabs: Typed description of product for each separate product or system.
  5. Text: Manufacturer's printed data (when available) or typewritten data on 20-pound bond paper.
  6. Drawings: Reduce full size drawings to 11' x 17" size.

### **3.05 WARRANTIES**

- A. Warranty Definitions:
1. Standard product warranties are preprinted written warranties published by individual manufacturers for particular products and are specifically endorsed by the manufacturer to VTA.
  2. Special warranties are written warranties required by or incorporated in the Contract Documents, either to extend time limits provided by standard warranties or to provide greater rights to VTA. When the Contract Documents require Contractor, or Contractor and subcontractor, supplier or manufacturer to execute a special warranty, Contractor

must prepare a written document that contains appropriate terms and identification, ready for execution by the required parties.

- B. Form of Submittal: Compile copies of each required warranty properly executed by Contractor, or by Contractor, subcontractor, supplier, or manufacturer. Organize the warranty documents into an orderly sequence based on the table of contents of these Technical Specifications.
- C. Provide additional copies of each warranty to include in operation and maintenance manuals.
- D. Bind warranties in heavy-duty, commercial-quality, durable 3-ring, vinyl-covered, loose-leaf binders, in thickness necessary to accommodate contents, and sized to receive 8-1/2 by 11 inch paper.
  - 1. Provide heavy paper dividers for each separate warranty. Provide and mark the tabs to identify the product or installation. Provide a typed description of the product or installation, including the name of the product, and the name, address, and telephone number of the Installer.
  - 2. Identify each binder on the front with the typed or printed title "WARRANTIES", Project title or name, and the name of Contractor.

### **3.06 REGULATORY APPLICATIONS AND PERMITS**

- A. Submit copies of permit applications, permits, inspection reports, notices, receipts for fee payments, correspondence, and similar documents, established for compliance with standards and regulations bearing on performance of the Work.
- B. Form of Submittal: Organize documents in proper sequence based on the orders and requests of the authorities having jurisdiction (AHJ).
- C. Bind the reports in heavy-duty, commercial-quality, durable 3-ring, vinyl-covered, loose-leaf binders, in thickness necessary to accommodate contents, and sized to receive 8-1/2 by 11 inch paper.
  - 1. Provide heavy paper dividers for each separate AHJ. Provide and mark the tabs to identify the Technical Specification Section. Provide a typed Table of Contents indicating the AHJ and the Technical Specification Section and title of each document.
  - 2. Identify each binder on the front with the typed or printed title "Regulatory Applications and Permits", Project title or name, and the name of Contractor.

### **3.07 TEST AND INSPECTION REPORTS**

- A. Prepare and submit certified written reports specified in other Sections. Include the following:
  - 1. Date of issue.
  - 2. Project title and Contract number.
  - 3. Name, address, and telephone number of testing agency.
  - 4. Dates and locations of samples and tests or inspections.
  - 5. Names of individuals making tests and inspections.

6. Description of test and inspection method.
  7. List of test equipment, and calibration date.
  8. Identification of product and Technical Specifications section.
  9. Complete test results.
  10. Analysis and interpretation of test results, including professional opinion on whether tested or inspected Work complies with Contract Documents requirements.
  11. Name and signature of responsible inspector or engineer.
  12. Recommendations on retesting and re-inspecting.
- B. Form of Submittal: Compile copies of each required test and inspection report. Organize the reports into an orderly sequence based on the table of contents of the Technical Specifications.
- C. Bind the reports in heavy-duty, commercial-quality, durable 3-ring, vinyl-covered, loose-leaf binders, in thickness necessary to accommodate contents, and sized to receive 8-1/2 by 11 inch paper.
1. Provide heavy paper dividers for each separate report. Provide and mark the tabs to identify the Technical Specification Section. Provide a typed Table of Contents indicating the Technical Specification Section and title of the required test and inspection report.
  2. Identify each binder on the front with the typed or printed title "Test and Inspection Reports", Project title or name, and the name of Contractor.

### **3.08 PRE-CONSTRUCTION SITE PHOTOS & CONSTRUCTION PROGRESS PHOTOS**

- A. Take photographs in good lighting, use camera flash or provide additional lighting as necessary to adequately capture subject area being photographed. Maintain camera steady to avoid motion blur. Retake pictures which are blurry or of poor quality.
- B. Save photographs in jpeg image file format with medium-high to high quality settings.
- C. Preserve photographs in their original resolution and image size. Do not resize, shrink, or down sample images to save file space.
- D. Contractor should utilize a camera that adds GPS based location information (geotagging) to the metadata of the image file. Do not post process image files in such a manner that the originally recorded metadata is cleared or removed.
- E. Acceptable photographic equipment:
1. Current model iOS or Android based camera phone with 8-megapixel (or better) image sensor, or 8-megapixel (or better) digital camera with GPS geotagging.
- F. Pre-construction photographic survey
1. Contractor must photographically document the existing site conditions over the entire project area before occupying or altering the site. There is no set number of photographs required, however Contractor must provide a representative summary of the existing conditions. Photograph all areas of work, equipment to be removed or altered, piping to removed or altered, locations where new equipment and piping is to be installed, and



other areas of relevance to Contractor's Work. Existing equipment or adjacent structures that are to remain, which appear to be in poor existing condition, should be documented. Site conditions which Contractor deems to be of concern should be documented.

G. Construction progress

1. Contractor must photographically document each area of construction and each phase of construction.
  - a. Take photographs at the beginning, middle, and end of each stage of construction for each major item of Work.
    - 1) Use the approved baseline CPM schedule as a guide for determining major items of Work and stages of construction. In general, individual schedule activities will be considered as major items of work.
  - b. Take project completion photographs between Substantial Completion and Final Acceptance. File project completion photographs separately. Document all areas of Work and items photographed during the pre-construction photographic survey.

**END OF SECTION 01 78 39**

*[This Page Intentionally Left Blank]*

**DIVISION 2 – EXISTING CONDITIONS**  
**SECTION 02 32 19 – POTHOLING**

**PART 1 – GENERAL**

**1.01 SECTION INCLUDES**

- A. Requirements for potholing of existing utilities.

**1.02 RELATED SECTIONS**

- A. Technical Specifications **Section 31 10 00 – Site Clearing**

**1.03 REFERENCES**

- A. California Government Code – Title 1 – Division 5 – Chapter 3.1 – Protection of Underground Infrastructure
  - 1. Section 4216 – Dig Alert & Safe Digging Guidelines

**1.04 SYSTEM DESCRIPTION**

- A. Provide potholing to verify the location (and type of) existing utilities with regard to protection of existing facilities and connections to existing utilities.

**1.05 SUBMITTALS**

- A. Submittal procedures must be in accordance with the applicable provisions of:
  - 1. **Section 6.6 Contract Data Requirements**
  - 2. **Section 7.41 Product Options, Supplier Approval and Substitutions**
  - 3. **Section 7.43 Submittal of Shop Drawings, Product Data and Samples**
  - 4. **Section 7.49.1 Certificate of Compliance**
  - 5. **Appendix B Contract Data Requirements**
- B. Proposed potholing excavation equipment.
- C. Preliminary pothole plan showing the proposed pothole locations.
- D. Report for each pothole dug under the provisions of this Section. Reports must be typed and clearly drawn to show all necessary details, including:
  - 1. Unique pothole number, precise pothole location, date, top and bottom depths, width of pothole, kind of utility encountered, type of pipe or conduit encountered, size of utility encountered, conditions encountered, method of backfill, company and person in charge of potholing, and any other relevant information.

**PART 2 – PRODUCTS (NOT USED)**

## **PART 3 – EXECUTION**

### **3.01 POTHOLING**

- A. Comply with California Government Code Section 4216 and follow safe digging practices.
- B. Review the Contract Drawings showing new construction and existing utilities. Pothole existing utilities, taking care not to damage the utilities. Pothole to a depth of 6' unless a utility is encountered shallower.
- C. Utilize personnel trained and experienced in underground utility locating and tracing.
- D. Use a hand held utility locator paired with "hand dig" equipment or "soft dig" vacuum excavation equipment.
- E. Chronologically number each pothole and mark the number of the pothole onto the pavement or ground adjacent to the pothole.
- F. Record the number of the pothole and identify the pothole location, including top and bottom of utility depths, type of pipe or conduit encountered, and size of utility encountered. Provide these notes to VTA at the end of each day that potholing is performed.
- G. Compare pothole markings to determine if existing utilities shown on the Contract Drawings have been identified in the field. If pothole markings and Contract Drawings do not match, notify VTA of findings immediately.
- H. If during potholing, existing utilities not shown on the Contract Drawings are found, or not found to be within reasonable proximity as shown on the Contract Drawings, take all precautionary measures to protect existing facilities from damage and notify VTA of findings immediately.
- I. Backfill holes and repair surfacing. Compact backfill to 95% compaction. Repair hardscaped surface with Asphalt Concrete (AC) or Concrete (PCC) to match existing. Section depth of repaired hardscape to match existing thickness, or 4" minimum of AC or PCC.
- J. Contractor will bear full responsibility for all damages and costs of repairs to existing utilities. Should any such utility be damaged during construction, all expenses of the restoration of the utility to its original service will be borne by Contractor.
- K. Unless otherwise indicated on the Contract Drawings, protect in place all water, heating hot water, propane (liquid and/or gaseous), sanitary sewer, storm drainage, electrical, telephone/communications, diesel fuel, transmission fluid, and motor oil lines, conduits, and structures. Protect in place any other surface or subsurface structures of any nature that may be affected by the Work, unless otherwise indicated on the Contract Drawings.

**END OF SECTION 02 32 19**

## SECTION 02 41 19 – SELECTIVE DEMOLITION

### PART 1 – GENERAL

#### 1.01 SECTION INCLUDES

- A. This Section includes demolition and removal of selected portions of a building, including removal of foundations.

#### 1.02 RELATED SECTIONS

- A. Technical Specifications **Section 01 73 00 – Execution**, for general requirements for patch and repair procedures.
- B. Technical Specifications **Section 31 10 00 – Site Clearing**, for removal of above and below grade site improvements.
- C. Refer to Contract Drawings and **Division 23** and **Division 26** of the Technical Specifications sections for specific requirements of the extent and limitations applicable to demolition, cutting and patching, or altering existing construction applicable to fueling, mechanical and electrical installations.
- D. **Section 6.14.2 Hazardous Substances**.

#### 1.03 DEFINITIONS

- A. Remove: Detach items from existing construction and legally dispose of them off-site, unless indicated to be removed and salvaged or removed and reinstalled.
- B. Remove and Salvage: Detach items from existing construction and deliver them to VTA.
- C. Remove and Reinstall: Detach items from existing construction, prepare them for reuse, and reinstall them.
- D. Existing to Remain: Existing items of construction that are not to be removed and that are not otherwise indicated to be removed, removed and salvaged, or removed and reinstalled.

#### 1.04 MATERIALS OWNERSHIP

- A. Except for items or materials indicated to be salvaged, reinstalled, or otherwise indicated to remain on VTA property, demolished materials will become Contractor's property and must be removed, recycled, or disposed from project site in an appropriate and legal manner.

#### 1.05 HAZARDOUS MATERIALS

- A. A limited asbestos, lead, and polychlorinated biphenyls (PCBs) survey, in preparation for the planned construction, was conducted by Burns McDonnell, and issued on November 5, 2018. Survey report is included in **Appendix O** of the Contract Documents.
- B. Examine asbestos, lead, and PCB report (**Appendix O**) to become aware of hazardous materials impacted by work shown on the Contract Documents.

#### **1.06 QUALITY ASSURANCE**

- A. Regulatory Requirements: Comply with governing regulatory requirements before beginning selective demolition. Comply with hauling and disposal regulations of Authorities Having Jurisdiction.

#### **1.07 SUBMITTALS**

- A. Submittal procedures must be in accordance with the applicable provisions of:
  - 1. **Section 6.6 Contract Data Requirements**
  - 2. **Section 7.41 Product Options, Supplier Approval and Substitutions**
  - 3. **Section 7.43 Submittal of Shop Drawings, Product Data and Samples**
  - 4. **Section 7.49.1 Certificate of Compliance**
  - 5. **Appendix B Contract Data Requirements**
- B. Schedule of Selective Demolition Activities: Refer to **Section 6.11 Work Sequence and Constraints**. Indicate the following:
  - 1. Detailed sequence of selective demolition and removal work, with starting and ending dates for each activity.
  - 2. Interruption of utility services.
  - 3. Coordination for shutoff, capping, and continuation of utility services.
- C. Closeout Submittals:
  - 1. Receipt and weight tickets from landfill operator or recycler (as applicable).
  - 2. Completed waste manifests.
  - 3. Disposal records.

#### **1.08 PROJECT CONDITIONS**

- A. VTA will occupy portions of building immediately adjacent to selective demolition area. Conduct selective demolition so VTA operations will not be disrupted.
- B. Maintain access to existing walkways and other adjacent occupied or used facilities.
  - 1. Do not close or obstruct walkways or other occupied or used facilities without permission from VTA.
- C. Utility Service: Maintain existing utilities indicated to remain in service and protect them against damage during selective demolition operations.

### **PART 2 – PRODUCTS**

#### **2.01 SALVAGED ITEMS**

- A. The Contract Drawings indicate the existing materials that are to be reinstalled in the new construction. Contractor shall remove, protect, and reinstall these items as indicated.
  - 1. Items for "Reinstallation" are indicated as such in the Contract Drawings.

- B. Materials scheduled for reinstallation which are damaged by Contractor to the extent that they cannot be reinstalled must be replaced by Contractor with equal quality material at no additional cost to VTA.

### **PART 3 – EXECUTION**

#### **3.01 EXAMINATION**

- A. Survey existing conditions and correlate with requirements indicated to determine extent of selective demolition required.
- B. Inventory and record the condition of items to be removed and reinstalled and items to be removed and salvaged.
- C. Perform surveys as the Work progresses to detect hazards resulting from selective demolition activities.

#### **3.02 PREPARATION**

- A. Temporary Facilities:
  - 1. Provide temporary barricades, warning signs, lights, delineators, shields, and other provisions necessary to protect passerby from injury or discomfort around the demolition area.
  - 2. Cover and protect furnishings and equipment that have not been removed, and are to remain in place during construction activities.

#### **3.03 POLLUTION CONTROLS**

- A. Stockpiling of Excavated Soil, Concrete and Surface Materials: Construct a staging area in the area directed by VTA for stockpiling of all excavated soil, concrete and surface materials. Stockpile excavated soil and debris on plastic sheeting and cover with plastic sheeting.
- B. Disposal: Remove and transport debris in a manner that will prevent spillage on adjacent surfaces and areas. Do not allow debris to accumulate in building or on site.
- C. Cleaning: Clean adjacent areas and equipment of dust, dirt, and debris caused by selective demolition operations. Return adjacent areas to condition existing before selective demolition operations began.
- D. No project related waste materials are to be disposed of in VTA's on-site waste bins or be allowed to remain on site after completion of project activities.

#### **3.04 DEMOLITION**

- A. General: Demolish and remove existing construction only to the extent required by new construction and as indicated. Use methods required to complete the Work within limitation of the Authorities Having Jurisdiction and as follows:
  - 1. Neatly cut openings and holes plumb, square, and true to dimensions required. Use cutting methods least likely to damage construction to remain or adjoining construction. To minimize disturbance of adjacent surfaces, use hand or small power tools designed for sawing or grinding, not hammering and chopping. Temporarily cover openings to remain.

2. Cut or drill from the exposed or finished side into concealed surfaces to avoid marring existing finished surfaces.
  3. Do not use sanding, abrasive blasting, or any other removal method that will create airborne lead or lead aerosols.
- B. Removed and Salvaged Items:
1. Clean salvaged items.
  2. Pack or crate items after cleaning. Identify contents of containers.
  3. Store items in a secure area until delivery to VTA.
- C. Removed and Reinstalled Items:
1. Clean and repair items to functional condition adequate for intended reuse.
  2. Pack or crate items after cleaning and repairing. Identify contents of containers.
  3. Reinstall items in locations indicated. Comply with installation requirements for new materials and equipment. Provide connections, supports, and miscellaneous materials necessary to make item functional for use indicated.
- D. Existing Items to Remain:
1. Protect construction indicated to remain against damage during selective demolition.
  2. Existing facilities, equipment or work that is not indicated to be removed, but interferes with new construction, must be removed as required to perform new Work.
- E. Lead Paint:
1. Removal of lead paint prior to demolition is not required if the paints is securely adhered to the substrates (non-flaking or non-peeling). Disposal of demolition debris in this case can be handled as non-hazardous waste. Spot abate all loose and flaking paint as hazardous waste.
- F. Plumbing:
1. Concealed piping within and below slab construction shall be identified, and capped a minimum of 3 inches below finish floor.
  2. Demolition of those portions of lines remaining must be capped with a fully threaded cap capable of withstanding 150% line pressure.
- G. Electrical:
1. Remove all abandoned electrical conductors, conduit, fastenings, boxes, Unistrut, miscellaneous angles and supports.
  2. Restore to its original operating condition all existing equipment and/or electrical wiring which is to remain, but has been removed to facilitate the installation of new equipment. Replace all removed wiring with new wiring.
  3. Removed fixtures and equipment must have all wiring removed back to the panel from which it is served.
    - a. Mark all disassociated breakers "spare".
    - b. If removal of wiring affects power to other outlets and fixtures to remain, provide J-boxes, etc., as necessary, to restore power to those outlets and fixtures. Any existing



to remain fixtures or J-boxes affected by removed conduit or conductor, must be modified by contractor to provide a safe condition and to preserve the service life of existing to remain equipment. Appropriately cover and seal any knock-outs or openings left by removed equipment.

- H. Provide additional select demolition as indicated in other Technical Specifications sections and Contract Drawings, and as required for new construction.
- I. Where any removed items result in holes or penetrations, provide appropriate covers or sealants to preserve insulative or weatherproof properties of existing construction to remain.

### **3.05 DISPOSAL OF REMOVED MATERIALS**

- A. Transport and dispose/recycle all removed materials generated during the performance of work, to an approved disposal site according to appropriate federal, state and local laws.
- B. All waste must be hauled by a licensed waste hauler with all required licenses from all state and local Authorities Having Jurisdiction.
- C. Comply with DOT, state and local regulations for containers. The most stringent regulation will apply.

### **3.06 DISPOSAL FACILITIES TESTING:**

- A. Contractor will be solely responsible for any testing of all demolition and removed items during the performance of work on this Contract.
- B. Perform all sampling and analytical work as required by treatment/disposal facilities receiving the material.
- C. All records, including waste manifests, Bill of Lading, and test results, must be provided to VTA.

### **3.07 CLEANING**

- A. Clean adjacent portions of the structures and improvements of dust, dirt and debris caused by demolition operations.
- B. Sweep the Worksite and broom clean on completion of selective demolition operations and every workday during the performance of the Contract. Vacuum adjacent surfaces as necessary to prevent accumulation of dust and debris from demolition operations.
- C. Keep Worksite free from accumulation of waste materials.
- D. Return adjacent areas to conditions existing prior to the start of the Work.

### **3.08 CLOSEOUT DOCUMENTATION**

- A. Prepare closeout documentation in accordance with Technical Specifications **Section 01 77 00 – Closeout Procedures**, and Technical Specifications **Section 01 78 39 – Project Record Documents**, to include the following:
  - 1. Receipt and weight tickets from landfill operator or recycler (as applicable).
  - 2. Completed waste manifests.

**END OF SECTION 02 41 19**

*[This Page Intentionally Left Blank]*

## SECTION 02 80 00 – HAZARDOUS MATERIAL REMOVALS

### PART 1 – GENERAL

#### 1.01 SECTION INCLUDES

- A. This Section includes:

Closure, removal, handling and disposal of an Aboveground Storage Tank (AST) containing hazardous material (Hazmat).

#### 1.02 RELATED SECTIONS

- A. **Section 6.14.1 Safety Supervision**  
B. **Section 6.14.2 Hazardous Substances**

#### 1.03 REFERENCES

- A. A limited asbestos, lead, and polychlorinated biphenyls (PCB) survey, in preparation for the planned construction, was conducted by Burns McDonnell, and issued on November 5, 2018. Survey report is included in **Appendix O** of the Contract Documents.
1. It is not anticipated that Contractor's Work will encounter asbestos or PCB's, however Contractor shall inform themselves and become aware of the potential presence at locations within the Cerone Division.
  2. Contractor's Work will involve the removal of existing equipment that may be painted with lead content paint. It is not anticipated that coatings will be peeling or flaking, or that Contractor's Work will require operations such as sanding or grinding of such painted surfaces. If lead content paint is encountered during the course of demolition, proceed with Work in accordance with Technical Specifications **Section 02 41 19 – Selective Demolition**, and all applicable regulatory standards for work involving lead content paint.
- B. County of Santa Clara Hazardous Materials Compliance Division (HMCD) – Refer to **Appendix N**, Permits, for additional requirements, including:
- HMCD-004, Plan submittal requirements for hazardous material systems
  - HMCD-017, Aboveground tank closure guidelines
  - HMCD-018, Aboveground tank closure permit application & plan
  - HMCD-111, Guidelines for on-site cleaning of hazardous materials storage tank systems

#### 1.04 REGULATORY REQUIREMENTS

- A. General Requirements:
1. All Work must be in accordance with this Technical Specification Section and the latest regulations from the U.S. Environmental Protection Agency (EPA), the U.S. Department of Transportation (DOT), the Occupational Safety and Health Administration (OSHA), the State of California Department of Industrial Relations - Division of Occupational Safety and Health (DOSH), the State of California Department of Industrial Relations (Cal/OSHA),

and any other applicable federal, state and regional AHJ. Whenever there is a conflict or overlap of the above references, the most stringent provision applies.

- B. Hazardous Material Storage Tank and Piping System. Comply with all applicable provisions of:
  - 1. California Aboveground Petroleum Storage Act (APSA).
  - 2. "Aboveground Tank Closure Guidelines" and "Guidelines for On-Site Cleaning of Hazardous Materials Storage Tank Systems", issued by the County of Santa Clara Department of Environmental Health - Hazardous Materials Compliance Division (HMCD). HMCD is the Certified Unified Program Agency (CUPA) for Santa Clara County.
  - 3. California Code of Regulations, Title 8, Department of Industrial Relations, Division of Industrial Safety – Boiler and Fired Pressure Vessel Safety Orders, as administered by the California Department of Industrial Relations, Division of Occupational Health (DOSH) - Pressure Vessel Unit.
  - 4. "Manual of Procedures", issued by the Bay Area Air Quality Management District.

#### **1.05 QUALITY ASSURANCE**

- A. Contractor Qualifications for hazardous material storage tank closure and removal:
  - 1. Contractor must assign an individual to perform the Work described in this section who satisfies the following minimum requirements:
    - a. The assigned individual must have completed, within the past five years, at least one commercial dismantling and removal of a Liquefied Petroleum Gas (LPG) storage tank system located in the State of California.
      - 1) Submit qualifications and references for subcontractor or individual(s) providing qualifying experience.

#### **1.06 PERMITS**

- A. Secure permits and inspections from all necessary local, regional, state, and federal agencies. These agencies include, but are not limited to: Bay Area Air Quality Management District (BAAQMD) and the Santa Clara County Department of Environmental Health - Hazardous Materials Compliance Division.
- B. County of Santa Clara Hazardous Materials Compliance Division (HMCD): Comply with all requirements of the Authority Having Jurisdiction (AHJ), including all conditions and requirements imposed by HMCD. Refer to the following for additional information:
  - 1. HMCD-004, Plan submittal requirements for hazardous material systems
  - 2. HMCD-017, Aboveground tank closure guidelines
  - 3. HMCD-018, Aboveground tank closure permit application & plan
  - 4. HMCD-111, Guidelines for on-site cleaning of hazardous materials storage tank systems

#### **1.07 SUBMITTALS**

- A. Submittal procedures must be in accordance with the applicable provisions of:

1. **Section 6.6 Contract Data Requirements**
  2. **Section 7.41 Product Options, Supplier Approval and Substitutions**
  3. **Section 7.43 Submittal of Shop Drawings, Product Data and Samples**
  4. **Section 7.49.1 Certificate of Compliance**
  5. **Appendix B Contract Data Requirements**
- B. Contractor Qualifications for hazardous material storage tank closure and removal - submit qualifications and references for subcontractor or individual(s) providing qualifying experience.
- C. Regulatory permit applications, and finalized permits required by **Appendix N**.
- D. Tank closure certification form.
- E. Provide training and Personal Protective Equipment (as required) for up to two (2) VTA employees.
- F. Hazardous Material Management Plan (HMMP), to include the following:
1. Work Plan: Detailed, job-specific plan for the safe management of hazardous materials encountered during performance of Work. Provide a plan of action with methods and procedures covering each identifiable hazard. All procedures used must provide for proper containment of petroleum fuel (in both liquid and gaseous states), heavy ends, contaminated slurry/sludge/debris, and all rinsates. Identify proposed treatment/disposal systems or facilities.
  2. Schedule: Provide a schedule detailing the estimated start and finish dates, crew size, and activity durations for all Hazmat related activities.
  3. Risks assessment: Provide an assessment of all potential safety risks involved with the AST closure and removal activities. For each identified safety risk, provide a mitigation plan.
  4. Emergency response plan: Work plan to be adhered to when a response is needed in a situation immediately dangerous to human life or the environment.
  5. Notification Plan: Implementation plan for notification to AHJs.
  6. Confined Space program and work plans, as applicable to the means and methods employed.
  7. Environmental monitoring plan: Contractor's plan for monitoring LEL (Lower Explosive Limit), oxygen concentration, and levels of other environmental conditions that present a safety hazard. Include approach for monitoring changes in conditions over time as the Work progresses. Include action plan for response to conditions that exceed hazardous thresholds.
  8. Contractor's standard operating procedures for safety and health.
  9. Training Program: Proof that training of all personnel engaged in Work under this Section is current and in accordance with regulatory requirements.

10. Detailed equipment list to be used, including employee Personal Protective Equipment (PPE).
  11. SDS for all chemicals to be used, or reference to the contractor's overall electronic SDS repository for the project (refer to **Section 6.14.3 Safety Data Sheets and Hazardous Substances**, for additional information).
- G. Closeout Submittals:
1. All sampling and test results for all work areas.
  2. Completed hazardous material waste manifests and bills of lading.
  3. Tank disposal certification.
  4. Analytical results of profile sampling/waste profiling data, for acceptance to treatment/disposal facility.
  5. Regulatory applications, notifications, and permits from all AHJs.
  6. Regulatory Certificates of Inspection from all AHJs.
  7. Contractor's Hazmat final clearance letter, certifying that all hazardous materials have been properly dispositioned, that all AHJ's have completed required inspections and sign-off's, and that hazardous materials management activities are complete.

#### **1.08 SAFETY REQUIREMENTS**

- A. All vehicles used to haul hazardous material from this site must display evidence of proper Department of Health Services (DOHS) and Department of Transportation (DOT) registration as a hazardous waste hauling vehicle.

#### **PART 2 – PRODUCTS (NOT USED)**

#### **PART 3 – EXECUTION**

##### **3.01 EXAMINATION**

- A. Examine the areas and conditions under which Work of this Section will be performed. Correct conditions detrimental to timely and proper completion of the Work. Do not proceed until unsatisfactory conditions are corrected.

##### **3.02 WORKER PROTECTION**

- A. Provide workers with training in accordance with 29 CFR 1926.
- B. Provide workers with appropriate personal protective equipment (PPE) that meets OSHA and EPA standards. Level of PPE required to be determined by certified industrial hygienist, according to the work being conducted. PPE must be worn by all workers in the applicable work area.
- C. As required to enable full unrestricted access for inspection and oversight activities, provide training and PPE for up to two (2) VTA employees to oversee Contractor activities and Work.

### **3.03 HANDLING AND DISPOSAL OF HAZARDOUS WASTE MATERIAL**

- A. Lead Paint: Removal of lead paint prior to demolition is not required if the paints are securely adhered to the substrates (non-flaking or non-peeling). Disposal of demolition debris in this case can be handled as non-hazardous waste. Spot abate all loose and flaking paint as hazardous waste.
- B. Seal any lead waste in leak-proof impermeable containment labeled in accordance with OSHA and EPA guidelines.
- C. All hazardous waste materials are to be hauled by a waste hauler with all required licenses from state and local Authority Having Jurisdiction.
- D. All vehicles used to haul hazardous material shall display evidence of current Department of Health Services (DOHS) and Department of Transportation (DOT) registration as a hazardous waste hauling vehicle.

### **3.04 PROPANE TANK CLOSURE WORK**

- A. Complete the "Aboveground Tank Closure Permit Application" and pay for the tank closure permit fee. Payment of the tank closure permit fee must be submitted with the closure permit application. VTA will submit Contractor's completed application and Contractor's permit fee to County of Santa Clara Department of Environmental Health - Hazardous Materials Compliance Division (HMCD).
- B. The completed tank closure permit and permit fee must be submitted to HMCD at least 14 days prior to tank removal.
- C. Tank removal may commence only after the HMCD inspector has given approval. Contractor's tank removal and sampling activities must be witnessed by a representative of HMCD.
- D. Remove all hazardous materials, including fuel from tanks and piping prior to tank and pipe removal.
- E. Drain, cap, dismantle, and triple rinse all tanks and piping.
- F. Containerize and transport off site for disposal all cleaning rinseate. All sludge, loose scale, residue, rinseate, and debris generated during the tank cleaning process shall be managed as hazardous waste.
- G. All cracks, holes, and other damaged section of the tank and piping must be plugged for transport, or transported in a liquid tight container.
- H. Prior to tank removal, add dry ice (carbon dioxide) or other methods approved by HMCD sufficient to achieve an atmosphere of either less than 10% oxygen or less than 20% Lower Explosive Limit (LEL). Confirm LEL readings with a properly calibrated combustible gas indicator (CGI). Record the readings in the Tank Closure Certification form.
- I. Submit Tank Closure Certification form. Form must be prepared by a contractor having a Hazardous Substance Removal Certification (HAZ) issued by the California Contractor's State License Board (CSLB), or a Certified Industrial Hygienist, or Certified Safety Professional.

- J. All tanks and piping must be manifested and hauled by a licensed hazardous waste transporter to a permitted hazardous waste facility, whether or not tanks and piping have been rinsed on site.
- K. Submit Bills of Lading for transport of tank and piping.
- L. Submit disposal certification for tank and piping.
- M. Submit Bill of Lading or Uniform Hazardous Waste Manifest for transport of residual fuel removed from each tank.
- N. Submit copies of Uniform Hazardous Waste Manifests associated with wastes generated during tank and pipe cleaning activities.

**3.05 DISPOSAL FACILITIES TESTING**

- A. Contractor will be solely responsible for any testing of all demolition and removed items during the performance of Work under this Contract.
- B. Perform all testing as required by acceptance requirements of treatment/disposal facilities receiving the material.
- C. Perform all sampling and analytical work required in accordance with local, state, and federal environmental regulation requirements.
- D. All analytical work must be performed by a certified environmental laboratory hired by Contractor.
- E. All records, including waste manifests, Bill of Lading must be provided to VTA.

**3.06 CLOSEOUT DOCUMENTATION**

- A. Prepare closeout documentation in accordance with Technical Specifications **Section 01 77 00 – Closeout Procedures**, and **Section 01 78 39 – Project Record Documents**, to include the following:
  - 1. Sampling results for all work areas.
  - 2. Completed hazardous waste manifests and Bills of Lading.
  - 3. Analytical results of profile sampling/waste profiling data, for acceptance to treatment/disposal facility.
  - 4. Regulatory applications, notifications, and permits from all AHJs.
  - 5. Regulatory certificates of inspection from all AHJs.
  - 6. Contractor’s final clearance inspection letter, certifying that all abatement activity is completed.

**END OF SECTION 02 80 00**



**DIVISION 3 – CONCRETE**  
**SECTION 03 10 00 – CONCRETE FORMING AND ACCESSORIES**

**PART 1 – GENERAL**

**1.01 SECTION INCLUDES**

- A. Formwork for concrete, with shoring, bracing and anchorage

**1.02 RELATED REQUIREMENTS**

- A. Technical Specifications **Section 03 20 00 – Concrete Reinforcing**
- B. Technical Specifications **Section 03 30 00 – Cast-In-Place Concrete**

**1.03 REFERENCE STANDARDS**

- A. ACI 117 - Standard Specifications for Tolerances for Concrete Construction and Materials.
- B. ACI 301 - Specifications for Structural Concrete for Buildings; American Concrete Institute.
- C. ACI 318 - Building Code Requirements for Structural Concrete and Commentary; American Concrete Institute.
- D. ACI 347 - Guide to Formwork for Concrete; American Concrete Institute.
- E. ASTM C31 - Standard Practice for Making and Curing Concrete Test Specimens in the Field.
- F. ASTM C39 - Standard Test Method for Compressive Strength of Cylindrical Concrete Specimens.
- G. ASTM D994 - Standard Specification for Preformed Expansion Joint Filler for Concrete (Bituminous Type).
- H. ASTM D1751 - Standard Specification for Preformed Expansion Joint Filler for Concrete Paving and Structural Construction (Non-extruding and Resilient Bituminous Types).

**1.04 SUBMITTALS**

- A. Submittal procedures shall be in accordance with the applicable provisions of:
  - 1. **Section 6.6 Contract Data Requirements**
  - 2. **Section 7.41 Product Options, Supplier Approval and Substitutions**
  - 3. **Section 7.43 Submittal of Shop Drawings, Product Data and Samples**
  - 4. **Section 7.49.1 Certificate of Compliance**
  - 5. **Appendix B Contract Data Requirements**
- B. Product Data: Provide data on formwork release agent or form liner proposed for use with each formed surface.
- C. Formwork Facing Materials: Data on form-facing materials proposed for smooth-form finish if different from that specified in Part 2.02.

- D. Construction and Contraction Joints: Location of construction and contraction joints proposed if different from those indicated in the Contract Documents.
- E. Shop Drawings
  - 1. All of the following shop drawings and calculations shall be prepared, stamped, and signed by a registered Civil or Structural Engineer of the State of California.
  - 2. Formwork: Submit shop drawings for fabrication and erection of forms for portions of the concrete surfaces, as indicated below:
    - a. For formwork over 12' in height.
    - b. Show general construction of forms including size of members, bracing, jointing, special form joint or reveals, location and pattern of form tie placement, and other items that affect the structural integrity of formwork or exposed concrete visually.

#### **1.05 QUALITY ASSURANCE**

- A. Codes and Standards: Comply with the provisions of the following codes, specifications, and standards, except where more stringent requirements are shown or specified.
  - 1. California Building Code, current governing edition
  - 2. ACI 318
  - 3. ACI 347

### **PART 2 – PRODUCTS**

#### **2.01 FORMWORK – GENERAL**

- A. Maximum deflection of facing materials reflected on concrete surfaces exposed to public view shall be 1/240 of the span between structural members of the formwork.
- B. Formed Construction and Contraction Joints
  - 1. Locate and form construction joints that least impair strength of the structure and meet the requirements of **Section 03 30 00 - Cast-in-Place Concrete**, Part 3.05.
  - 2. Unless otherwise specified or permitted, locate and detail formed construction joints to the following requirements:
    - a. Locate construction joints within the middle third of the spans of slabs, beams, and girders;
    - b. Make joints perpendicular to the main reinforcement.

#### **2.02 FORM MATERIALS**

- A. Form-facing materials: Materials for form faces in contact with concrete shall meet the requirements of "Concrete Finishing" **Section 03 30 00 - Cast-in-Place Concrete** and the following requirements unless otherwise specified in Contract Documents.
  - 1. For smooth-form finish, use plywood, tempered concrete-form-grade hardboard, metal, plastic, paper, or other acceptable materials capable of producing the desired finish for form-facing materials. Form-facing materials shall produce a smooth, uniform texture on

the concrete. Do not use form-facing materials with raised grain, torn surfaces, worn edges, dents, or other defects that will impair the texture of concrete surfaces. Facing materials shall be supported with studs or other backing capable of maintaining deflections within the tolerances specified in Part 2.01.

**2.03 FORMWORK ACCESSORIES**

- A. Use commercially manufactured accessories for formwork accessories that are partially or wholly embedded in concrete, including ties and hangers. Do not use nonfabricated wire form ties.

**2.04 FORMWORK RELEASE AGENT**

- A. Use commercially manufactured formwork release agents that prevent formwork absorption of moisture, prevent bond with concrete, and do not stain the concrete surfaces.

**2.05 EXPANSION JOINT FILLER**

- A. Premolded expansion joint filler shall conform to ASTM D994 or ASTM D1751.

**2.06 FABRICATION AND MANUFACTURE**

- A. Formwork shall be tight to prevent loss of mortar from concrete.
- B. Inspect formwork and remove deleterious material immediately before concrete is placed.
- C. Fabricate form ties so ends or end fasteners can be removed with minimum spalling at the faces of concrete.

**PART 3 – EXECUTION**

**3.01 EARTH FORMS**

- A. Where sides of excavations have been cut neat and accurate to size for pouring of concrete directly against the excavation, forms for footings will not be required. Remove loose soil prior to placing concrete.

**3.02 CONSTRUCTION AND ERECTION OF FORMWORK**

- A. At construction joints, lap contact surface of the form sheathing for flush surfaces exposed to view over the hardened concrete in the previous placement. Ensure formwork is sealed against hardened concrete to prevent offsets or loss of mortar at construction joints and to maintain a true surface.
- B. Provide positive means of adjustment (such as wedges or jacks) of shores and struts. Do not make adjustments in the formwork after concrete has reached its time of initial setting. Brace formwork securely against lateral deflection and lateral instability.
- C. Fasten form wedges in place after final adjustment of forms and before concrete placement.
- D. Anchor formwork to shores, supporting surfaces, or members to prevent upward or lateral movement of the formwork system during concrete placement. Form supports shall be placed on adequate foundations and have sufficient strength and bracing to prevent settlement or distortion from the weight of the concrete or other cause. Support shall rest

on double wedged shim, or other approved means, so that the forms will be maintained at the proper grade.

- E. Provide runways for moving equipment and support runways directly on the formwork or structural member without resting on the reinforcing steel.
- F. All formed joints on concrete surfaces to be exposed shall be taped and shall align so joints will not be apparent on the concrete surfaces.
- G. Any movement or bellying of forms during construction shall be considered just cause for their removal and, in addition, the concrete work so affected.
- H. Bolts, rods, or other approved devices shall be used for internal form ties and shall be of sufficient quantities to prevent spreading of the forms. The ties shall be placed at least 1 inch away from the finished surface of the concrete. Bolts and rods that are to be completely withdrawn shall be coated with grease.
- I. Boards or other form materials that have been damaged or checked or warped prior to placing of concrete shall be removed from the forms and replaced with approved materials or otherwise corrected to the satisfaction of VTA.
- J. Assign a sufficient number of men to keep watch on and maintain the forms during placing of concrete. Satisfactorily remedy any displacement or looseness of forms or reinforcement before placing of concrete. No form shall be moved or altered except as may be specifically directed.

### **3.03 APPLICATION - FORM RELEASE AGENT**

- A. Cover surfaces of formwork with an acceptable material that will prevent bond with the concrete. A field-applied formwork release agent or a factory-applied liner may be used. If a formwork release agent is used, apply to the surfaces of the formwork in accordance with the manufacturer's recommendations before placing reinforcing steel. Do not allow formwork release agent to puddle in the forms. Do not allow formwork release agent to contact reinforcing steel or hardened concrete against which fresh concrete is to be placed.

### **3.04 FORM CLEANING**

- A. Clean surfaces of formwork and embedded materials of mortar, grout, and foreign materials before concrete is placed.

### **3.05 FORMWORK TOLERANCES**

- A. Unless otherwise specified in the Contract Documents, construct formwork so concrete surfaces conform to the tolerance limits of ACI 117. The class of surface shall conform to Part 2.02.
- B. To maintain specified tolerances, camber formwork to compensate for anticipated deflections in formwork during concrete placement. Set formwork and intermediate screed strips for slabs accurately to produce designated elevations and contours of the finished surface before removal of formwork. Ensure that edge forms and screed strips are strong enough to support vibrating screeds or roller pipe screeds when the finish specified requires the use of such equipment.

- C. When formwork is cambered, set screeds to the same camber to maintain specified concrete thickness.

**3.06 FIELD QUALITY CONTROL**

- A. The Contractor shall verify accuracy of items, furnished under other sections of these specifications and installed under this section.

**3.07 FORM REMOVAL**

- A. Do not damage concrete during removal of formwork for columns, walls, slabs, sides of beams, and other parts not supporting the weight of the concrete. Perform needed repair and treatment required on vertical surfaces at once and follow immediately with specified curing.
- B. Leave formwork in place to support slabs for at least 10 days, until concrete has attained 2000 psi minimum, or until the Engineer responsible for design of formwork has approved removal.
- C. Vertical forms shall remain in place for at least 10 days after the last concrete and until concrete has attained 2000 psi minimum, and the Engineer responsible for design of the formwork has approved removal.
- D. In removing plywood forms, no metal pinch bars shall be used and special care to be taken in stripping. Start at top edge or vertical corner where it is possible to insert wooden wedges. Wedging shall be done gradually and shall be accompanied by light tapping of the plywood panels to crack them loose. Do not remove forms with a single jerk after it has been started at one end.

**END OF SECTION 03 10 00**

*[This Page Intentionally Left Blank]*

## **SECTION 03 20 00 – CONCRETE REINFORCING**

### **PART 1 – GENERAL**

#### **1.01 SECTION INCLUDES**

- A. Reinforcing steel for concrete, shotcrete and masonry.
- B. Supports and accessories for steel reinforcement

#### **1.02 RELATED REQUIREMENTS**

- A. Technical Specifications **Section 03 10 00 – Concrete Forming and Accessories**
- B. Technical Specifications **Section 03 30 00 – Cast-In-Place Concrete**

#### **1.03 REFERENCE STANDARDS**

- A. ACI 117 - Standard Specifications for Tolerances for Concrete Construction and Materials; American Concrete Institute International.
- B. ACI 301 - Specifications for Structural Concrete for Buildings; American Concrete Institute International.
- C. ACI 318 - Building Code Requirements for Structural Concrete and Commentary; American Concrete Institute International.
- D. ACI SP-66 - ACI Detailing Manual; American Concrete Institute International.
- E. ASTM A1064 - Standard Specification for Steel Wire, Plain, for Concrete Reinforcement.
- F. ASTM A123 - Standard Specification for Zinc (Hot-Dip Galvanized) Coatings on Iron and Steel Products
- G. ASTM A185 - Standard Specification for Steel Welded Wire Reinforcement, Plain, for Concrete.
- H. ASTM A615 - Standard Specification for Deformed and Plain Billet-Steel Bars for Concrete Reinforcement.
- I. ASTM A 641 - Standard Specification for Zinc-Coated (Galvanized) Carbon Steel Wire.
- J. ASTM A706 - Standard Specification for Low-Alloy Steel Deformed and Plain Bars for Concrete Reinforcement.
- K. ASTM A767 - Standard Specification for Zinc-Coated (Galvanized) Steel Bars for Concrete Reinforcement.
- L. ASTM A775 - Standard Specification for Epoxy-Coated Steel Reinforcing Bars.
- M. ASTM A780 - Standard Practice for Repair of Damaged and Uncoated Areas of Hot-Dip Galvanized Coatings.
- N. ASTM A884 - Standard Specification for Epoxy-Coated Steel Wire and Welded Wire Reinforcement.
- O. ASTM A934 - Standard Specification for Epoxy-Coated Prefabricated Steel Reinforcing Bars.

- P. ASTM D3963 - Standard Specification for Fabrication and Jobsite Handling of Epoxy Coated Reinforcing Steel Bars.
- Q. ASTM E329 - Standard Specification for Agencies Engaged in Construction Inspection and/or Testing.
- R. AWS D1.4 - Structural Welding Code - Reinforcing Steel; American Welding Society.
- S. CRSI (DA4) - Manual of Standard Practice; Concrete Reinforcing Steel Institute.

#### **1.04 SUBMITTALS**

- A. Submittal procedures shall be in accordance with the applicable provisions of:
  - 1. **Section 6.6 Contract Data Requirements**
  - 2. **Section 7.41 Product Options, Supplier Approval and Substitutions**
  - 3. **Section 7.43 Submittal of Shop Drawings, Product Data and Samples**
  - 4. **Section 7.49.1 Certificate of Compliance**
  - 5. **Appendix B Contract Data Requirements**
- B. Shop Drawings (Placing drawings)
  - 1. Comply with requirements of ACI SP-66. Shop drawings shall also show details for congested areas and connections. Shop drawings used in field must be reviewed copies.
- C. Product Data
  - 2. Manufacturer's catalog sheets including instructions for use and description of application and ICC/IAPMO evaluation report shall be provided on each of the following items intended for use on project:
    - a. Mechanical anchorage devices for splices.
- D. Mill Certificates
  - 1. The Contractor shall provide Mill Certificates for each size of bar for each heat to be used on project and certify that reinforcing steel supplied for this project meet or exceed specified requirements.
  - 2. Mill Certificates shall include name of mill, date of rolling, date of shipping to fabricator and shall be signed by fabricator certifying that each material complies with or exceeds the specified requirements. A Mill Certificate shall be furnished with each lot of material delivered to the project and the lot shall be clearly identified in the Certificate.
  - 3. When Mill Certificates cannot be provided, the Contractor shall hire a professional testing laboratory to verify compliance and provide laboratory test reports. The Contractor shall pay for the cost of testing.
- E. Testing Agency Qualifications
- F. Testing Agency Reports
  - 1. Laboratory test reports shall be signed by a principal of the testing agency who is a registered Civil Engineer in the State of California.



2. When required by other portions of these specifications, laboratory test reports shall be submitted for each size of bar tested for each heat to show compliance with appropriate ASTM Standards and these specifications.
- G. Welder's Certificates and WPS: Submit description of reinforcement weld locations, welding procedures, and welder certification when welding is permitted.

#### **1.05 QUALITY ASSURANCE**

- A. Perform work of this section in accordance with the current governing edition of CBC, ACI 301, ACI SP-66, ACI 318, and AWS D1.4 except as modified by the contract documents.
- B. Sampling and Testing:
  1. General
    - a. If VTA has accepted material or work which is defective or contrary to specifications, this material or work, regardless of state of completion, may be rejected.
    - b. Testing agencies shall meet the requirements of ASTM E329. Testing agencies shall be accepted by the Architect/Engineer before performing any work.
  2. Testing responsibilities of Contractor:
    - a. Submit data on qualifications of proposed testing agency for acceptance. Use of testing services will not relieve the Contractor of the responsibility to furnish materials and construction in compliance with the Contract Documents.
    - b. Cooperate with and notify VTA at least two working days in advance of inspections required and shall provide samples, test pieces, and facilities for inspection at no cost to VTA.
    - c. Identify each lot of fabricated reinforcing steel to be shipped to the site by assigning an individual lot number that identifies steel by heat number and shall be tagged in such a manner that each such lot can be accurately identified at the job site.
    - d. Remove all unidentified reinforcing steel, anchorage assemblies and bar couplers received at the site.

#### **1.06 STORAGE OF MATERIALS**

- A. Store reinforcement during fabrication and at site to avoid excessive rusting or coating with grease, oil, soil, or other objectionable materials.

#### **1.07 SEQUENCING AND SCHEDULING**

- A. Coordinate work with all trades so as not to interfere with the work of other trades. Bring interferences between trades to VTA's attention and resolve before any concrete is placed.

### **PART 2 – PRODUCTS**

#### **2.01 REINFORCING BARS**

- A. Reinforcing Steel:
  1. ASTM A615, Grade 60 bars

- a. Actual yield strength based on mill tests must not exceed the specified yield strength by more than 18,000 psi (retest shall not exceed this value by more than an additional 3,000 psi) and the ratio of the actual ultimate tensile stress to the actual tensile yield strength is not less than 1.25. This must be verified by the special inspector prior to bundle tag removal.

2. Uncoated steel unless noted otherwise.

## **2.02 WIRE**

- A. All wire for concrete reinforcement shall conform to ASTM A1064.

## **2.03 REINFORCEMENT ACCESSORIES**

- A. Chairs, Bolsters, Bar Supports, Spacers: Sized and shaped for adequate support of reinforcement during concrete placement. Reinforcement supports shall conform to the requirements of ACI 301.

## **2.04 OTHER MATERIALS**

- A. All other materials, not specifically described by these specifications but required for complete and proper placement of reinforcement shall be new, first quality of their respective kinds, and subject to the approval of VTA.

## **2.05 FABRICATION**

- A. Welding of reinforcement is permitted only with the specific approval of VTA. Perform welding in accordance with AWS D1.4. Do not weld crossing bars (tack welds) for assembly of reinforcement, supports, or embedded items. After completing welds on galvanized or epoxy-coated reinforcement, repair coating damage as mentioned in Part 2.01.

# **PART 3 – EXECUTION**

## **3.01 EXISTING CONDITIONS**

- A. Prior to all work of the section, carefully inspect the installed work of other trades and verify that all work is sufficiently complete to permit the start of work under this section and that the completed work of this section will be in complete accordance with the original design and the reviewed shop drawings. In the event of discrepancy, immediately notify VTA in writing.
- B. In the event conduits, pipes, inserts, sleeves, or any other items interfere with placing the reinforcement as indicated on the Contract Drawings or approved shop drawings, or as otherwise required, immediately notify VTA and obtain approval on procedure before placement of reinforcement is started.

## **3.02 BENDING**

- A. Bends for reinforcing steel shall be made in accordance with ACI 301 and ACI 318. Bend bar sizes No. 3 through 5 cold only one time, provided reinforcing bar temperature is above 32 degree F. Do not field bend reinforcing steel in a manner that will injure material, cause the bars to be bent on too tight a radius, or that is not indicated as allowed on Contract Drawings or permitted by VTA. Do not straighten bent or kinked bars for use on project without

permission of VTA. Replace bars with kinks or bends not shown on the shop drawings or Contract Drawings.

### **3.03 PLACING**

- A. All reinforcement shall be placed in strict conformance with the requirements of the Contract Drawings, both as to location, position and spacing of members. It shall be supported and secured against displacement by the use of adequate and proper wire supporting and spacing devices, tie wires, etc. so that it will remain in its proper position in the finished structure. Reinforcement may not be wet set in concrete pours.
- B. Tolerances: Do not exceed the placing tolerances specified in ACI 318 and ACI 117, whichever is more stringent, before concrete is placed. Placing tolerances shall not reduce cover requirements except as specified in ACI 117.
- C. Minimum concrete cover for reinforcement and couplers shall be as indicated in the Contract Drawings. Concrete cover is measured from the theoretical excavation line, not the line of any over excavation. Where less than 3 inches cover is noted and concrete will be placed against soil, increase the section thickness to attain 3 inches cover.
- D. Preserve clear space between parallel bars of not less than 1-1/2 times the nominal diameter of round bars and in no case let the clear distance be less than 1-1/2 inches nor less than 1-1/3 times the maximum size of aggregate for concrete.
- E. For slabs on ground, extend welded wire reinforcement to within 2 in. of the concrete edge. Reinforcement shall be lapped and tied around the perimeter of each sheet in order to maintain the proper positioning of the reinforcement. Lap splices shall have a minimum of two ties per spliced length. Do not place welded wire reinforcement on grade and subsequently raise into position in concrete.
- F. Lap splices shall be contact lap splices in accordance with ACI 318 unless noted otherwise on the Contract Drawings. Bars shall be wired together at laps. Wherever possible, stagger splices in adjacent bars. Splice bars in members such as spandrels, beams, etc, as follows: Top bars at centerline of span, bottom bars at the support. Make all splices in welded wire reinforcement at least 1-1/2 meshes wide or 12 inches, whichever is greater. When splicing in areas to receive shotcrete, lap splices shall be non-contact with at least 2 inches clearance between bars.
- G. Butt splices shall be accomplished by mechanical anchorage devices. Stagger these devices 2 feet, unless noted otherwise on the Contract Documents.
- H. Bars shall not be cut by gas torch.

### **3.04 CLEANING REINFORCEMENT**

- A. Take all means necessary to ensure that steel reinforcement, at the time concrete is placed around it, is completely free from rust, soil, loose mill scale, oil, paint and all coatings which will destroy or reduce the bond between steel and concrete.

**END OF SECTION 03 20 00**

*[This Page Intentionally Left Blank]*

## **SECTION 03 30 00 – CAST-IN-PLACE CONCRETE**

### **PART 1 – GENERAL**

#### **1.01 SECTION INCLUDES**

- A. Cast-in-place structural concrete.
- B. Supply and application of curing and bond breaker compounds.
- C. Patching and finishing concrete after form removal.
- D. Installation of concrete expansion anchors.
- E. Installation of epoxy anchored reinforcing dowels.
- F. Special Inspection of anchor and dowel installations.
- G. Installation of snap ties.
- H. Concrete admixtures for retarding set, accelerating set, reducing water content, etc.

#### **1.02 RELATED REQUIREMENTS**

- A. Technical Specifications **Section 03 10 00 – Concrete Forming and Accessories**
- B. Technical Specifications **Section 03 20 00 – Concrete Reinforcing**
- C. Technical Specifications **Division 23** and **Division 26** Sections for fueling and electrical items for casting into concrete.

#### **1.03 REFERENCE STANDARDS**

- A. ACI 117 - Standard Specifications for Tolerances for Concrete Construction and Materials; American Concrete Institute International.
- B. ACI 211.1 - Standard Practice for Selecting Proportions for Normal, Heavyweight, and Mass Concrete; American Concrete Institute International.
- C. ACI 301 - Specifications for Structural Concrete for Buildings; American Concrete Institute International.
- D. ACI 302.1R - Guide for Concrete Floor and Slab Construction; American Concrete Institute International.
- E. ACI 306.1 - Cold Weather Concreting; American Concrete Institute International.
- F. ACI 308R - Guide to Curing Concrete; American Concrete Institute International.
- G. ACI 318 - Building Code Requirements for Structural Concrete and Commentary; American Concrete Institute International.
- H. ASTM C31 - Standard Practice for Making and Curing Concrete Test Specimens in the Field.
- I. ASTM C33 - Standard Specification for Concrete Aggregates.
- J. ASTM C39 - Standard Test Method for Compressive Strength of Cylindrical Concrete Specimens.

- K. ASTM C42 - Standard Test Method for Obtaining and Testing Drilled Cores and Sawed Beams of Concrete.
- L. ASTM C94 - Standard Specification for Ready-Mixed Concrete.
- M. ASTM C143 - Standard Test Method for Slump of Hydraulic-Cement Concrete.
- N. ASTM C150 - Standard Specification for Portland Cement.
- O. ASTM C157 - Standard Test Method for Length Change of Hardened Hydraulic-Cement Mortar and Concrete.
- P. ASTM C171 - Standard Specification for Sheet Materials for Curing Concrete.
- Q. ASTM C173 - Standard Test Method for Air Content of Freshly Mixed Concrete by the Volumetric Method.
- R. ASTM C260 - Standard Specification for Air-Entraining Admixtures for Concrete.
- S. ASTM C309 - Standard Specification for Liquid Membrane-Forming Compounds for Curing Concrete.
- T. ASTM C330 - Standard Specification for Lightweight Aggregates for Structural Concrete.
- U. ASTM C494 - Standard Specification for Chemical Admixtures for Concrete.
- V. ASTM C567 - Standard Test Method for Determining Density of Structural Lightweight Concrete.
- W. ASTM C618 - Standard Specification for Coal Fly Ash and Raw or Calcined Natural Pozzolan for Use in Concrete.
- X. ASTM C881 - Standard Specification for Epoxy-Resin-Base Bonding Systems for Concrete.
- Y. ASTM C 979 - Standard Specification for Pigments for Integrally Colored Concrete.
- Z. ASTM C1077 - Standard Practice for Laboratories Testing Concrete and Concrete Aggregates for Use in Construction and Criteria for Laboratory Evaluation.
- AA. ASTM C1107 - Standard Specification for Packaged Dry, Hydraulic-Cement Grout (Nonshrink).
- BB. ASTM C1116 - Standard Specification for Fiber-Reinforced Concrete.
- CC. ASTM C1218 - Standard Test Method for Water-Soluble Chloride in Mortar and Concrete.
- DD. ASTM C1602 - Standard Specification for Mixing Water Used in the Production of Hydraulic Cement Concrete.
- EE. ASTM D1751 - Standard Specification for Preformed Expansion Joint Filler for Concrete Paving and Structural Construction (Nonextruding and Resilient Bituminous Types).
- FF. ASTM D4832 - Standard Test Method for Preparation and Testing of Controlled Low Strength Material (CLSM) Test Cylinders.
- GG. ASTM E1155 - Standard Test Method for Determining FF Floor Flatness and FL Floor Levelness Numbers.

#### 1.04 SUBMITTALS

- A. General Requirements: Submittals procedures shall be in accordance with the applicable portions of:
  - 1. **Section 6.6 Contract Data Requirements**
  - 2. **Section 7.41 Product Options, Supplier Approval and Substitutions**
  - 3. **Section 7.43 Submittal of Shop Drawings, Product Data and Samples**
  - 4. **Section 7.49.1 Certificate of Compliance**
  - 5. **Appendix B Contract Data Requirements**
- B. Product Data
  - 1. Manufacturer's catalog sheets including instructions for use and description of application shall be provided on each of the following materials:
    - a. Epoxies
    - b. Grout
    - c. Admixtures
    - d. Curing Compounds
    - e. Chemical Hardener
    - f. Adhesive Anchoring System
- C. Mix Designs
  - 1. Mix designs shall be submitted for each class of concrete on the job and shall show names and brands of all materials, proportions, slump, strength, gradation of coarse and fine aggregates, and location to be used on job. Field test records or test data that is used to establish the average compressive strength of the mixture shall be submitted.
- D. Concrete Placement Schedule: The Contractor shall submit a concrete placement schedule which shall show all proposed construction joint locations, limits of each placement sequence, order of placement and type of joint proposed at each joint location.
- E. Certificates of Compliance
  - 1. The Contractor shall provide Certificate of Compliance for each type of aggregate, cementitious material and admixture to be used in each class of concrete or a Certificate of Compliance for each class of concrete.
  - 2. Certificates of Compliance for cementitious materials shall include type, manufacturing location, shipping location; for aggregates: type, pit or quarry location, producers' name, grading, specific gravities and certification evidence not more than 90 days old; for admixtures: type, brand name, producer, manufacturer's technical data sheet, and certification data; and for water: source of supply that are used in each class of concrete and shall be signed by the concrete supplier certifying that each material item complies with, or exceeds the specified requirements. Certificates of Compliance shall be furnished 60 days in advance of any concrete pours.

3. When Certificates of Compliance cannot be provided, the Contractor shall hire a professional testing laboratory to verify compliance of each type of material to be used in each Class of Concrete. The cost of testing shall be paid for by the Contractor.

F. Weight and Batch Tags:

The special inspector shall be provided with a weight and batch tag upon delivery of each load of concrete. The batch tag must show weight of all materials.

G. Qualifications of Contractor's proposed testing agency.

H. Testing agency's concrete inspection and test reports.

**1.05 QUALITY ASSURANCE**

A. Comply with the provisions of the current governing CBC, ACI 301, and ASTM C94 except where more stringent requirements are shown or specified.

B. Sampling, Testing and Inspection:

1. General:

- a. If VTA, through oversight or otherwise, has accepted material or work which is defective or contrary to specifications, this material or work, regardless of state of completion, may be rejected.
- b. Testing agencies shall meet the requirements of ASTM C1077. Testing agencies shall be accepted by VTA before performing any work.

2. Contractor:

- a. The Contractor shall cooperate with and notify VTA at least two working days in advance of inspection required and shall provide samples and facilities for inspection without extra charge.
- b. The Contractor shall provide and maintain adequate facilities on the project site for safe storage and initial curing of concrete test specimens as required by ASTM C31 for the sole use of the testing agency.
- c. Each mix design shall be verified by trial batch tests or field test records and certified to by a principal of a testing agency who is a registered Civil Engineer in the State of California and submitted to VTA for review. Agency field test records, in order to be acceptable, must satisfy the requirement of ACI 318 section 5.3 otherwise trial mixture meeting the requirements of ACI 318 section 5.3 shall be made. The Contractor shall submit data on qualifications of proposed testing agency for acceptance and hire the accepted testing agency to provide trial mixture test data for each type of concrete on the job.

**1.06 SEQUENCING AND SCHEDULING**

A. Obtain information and instructions from other trades and suppliers in ample time to schedule and coordinate the installation of items furnished by them to be embedded in concrete so provision for their work can be made without delaying the project.

B. Perform any coring and infill of cored holes that were required by failed test results from test panels, failure or delay in complying with these requirements, at no cost to VTA.



## **PART 2 – PRODUCTS**

### **2.01 FORMWORK**

- A. Comply with requirements of **Section 03 10 00**.

### **2.02 REINFORCEMENT**

- A. Comply with requirements of **Section 03 20 00**.

### **2.03 CEMENTITIOUS MATERIALS**

- A. Portland Cement: ASTM C150, Type II.
- B. Fly Ash: ASTM C618, Class F or Class C.
  - 1. Fly ash may substitute for portland cement up to a maximum of 25% of total cementitious materials by weight (fly ash, if used, must substitute for 15% of the total cementitious materials by weight, minimum).
    - a. Substitutions that combine fly ash and ground granulated blast-furnace slag are limited to a combined total of 50% of the total cementitious material by weight with fly ash no more than 25% of the total cementitious materials by weight.
    - b. Reduce slag and fly ash substitution rates by at least 50% for cold weather concreting as defined in ACI 306.1.
- C. Ground-granulated Blast-furnace Slag: ASTM C989 grades 100 or 120
  - 1. Ground-granulated Blast-furnace Slag may substitute for portland cement up to a maximum of 50% of the total cementitious material by weight.
- D. Use cementitious materials that are of the same brand and type and from the same plant of manufacture as the cementitious materials used in the concrete represented by the submitted field test records or used in the trial mixtures.
- E. Fiber Reinforcement: Synthetic Fiber; fibrillated polypropylene fibers designed for use in concrete, complying with ASTM C1116, Type III, 1/2 inch to 1-1/2 inch in length.

### **2.04 AGGREGATES**

- A. Aggregates for hardrock concrete shall conform to ASTM C33.
- B. Lightweight Aggregate: ASTM C330.
- C. Aggregates used for entire project shall be obtained from the same sources and have the same size ranges as the aggregates used in the concrete represented by submitted historical data or used in trial mixtures.

### **2.05 WATER**

- A. Mixing Water for concrete shall be clean and free from deleterious amounts of chlorides, acids, alkalis or organic materials.

### **2.06 CHEMICAL ADMIXTURES**

- A. Do not use chemicals that contain calcium chloride or will result in total soluble chloride ions in hardened concrete at ages from 28 to 42 days contributed from water, aggregates,

cementitious materials, and admixtures in excess of 0.30 percent by weight of cement for reinforced concrete and 0.06 percent by weight of cement for prestressed concrete. Measure water-soluble chloride-ion content in accordance with ASTM C1218. Admixtures containing chloride salts shall not be used where concrete is poured on top of the metal deck. Calcium chloride or any admixture containing chloride ions shall not be used in drilled piers.

- B. Air Entrainment Admixture: ASTM C260.
  - 1. Acceptable Products subjected to compliance with requirements:
    - a. Sika Aer; Sika Corporation.
    - b. MB-VR or MB-AE; Master Builders.
    - c. Darex AEA; W.R. Grace.
    - d. Or approved equal.
- C. High Range Water Reducing and Retarding Admixture: ASTM C 494 Type G.
- D. High Range Water Reducing Admixture (Super Plasticizer): ASTM C494 Type F.
  - 1. Page 8-162 Acceptable Products subjected to compliance with requirements:
    - a. WRDA19; W.R. Grace.
    - b. Sikament; Sika Chemical Corporation.
    - c. Pozzolith 400; Master Builders.
    - d. Or approved equal.
- E. Water Reducing and Retarding Admixture: ASTM C494 Type D.
  - 1. Acceptable Products subjected to compliance with requirements:
    - a. Pozzolith 300-R; Master Builders.
    - b. Daratard; W.R. Grace.
    - c. Plastiment; Sika Chemical Corporation.
    - d. Or approved equal.
- F. Water Reducing Admixture: ASTM C494 Type A.
  - 1. Acceptable Products subjected to compliance with requirements:
    - a. Eucon WR-75; Euclid Chemical Company.
    - b. Pozzolith 344; Master Builders.
    - c. Plastocrete 160; Sika Chemical Corporation.
    - d. Or approved equal.
- G. Admixtures used in concrete shall be the same as those used in the concrete represented by the submitted field test records or used in the trial mixtures.

## **2.07 ACCESSORY MATERIALS**

- A. Non-Shrink Grout:

1. ASTM C1107 Grade B or C, pre-mixed, high strength, Metallic or non-metallic flowable grout, which does not shrink as it cures. Water-soluble chloride ion content of grout less than 0.06 percent chloride ion by weight of cement when tested in accordance with ATM C1218.
  - a. Minimum Compressive Strength at 7 Days: 5000 psi.
  - b. Subject to compliance with requirements provide one of the following:
    - 1) Metallic
    - 2) Non-metallic
- B. Expansive Grout:
  1. Expansive grout shall be composed of cement, sand, water and intraplast-N expanding grouting aid (manufactured by Sika, or approved equal). Expansive grout shall be proportioned and installed in accordance with intraplast-N recommendations and shall develop a minimum compressive strength of 3000 psi in 28 days.
- C. Post-Installed Anchoring Systems:
  1. Adhesive anchoring system
    - a. Adhesive anchoring system shall be HILTI-HY 200 (ESR-3187) or approved equal with a current ICC/IAPMO evaluation report.
  2. Expansion anchors and screw anchors
    - a. Expansion anchors shall be HILTI KWIK BOLT TZ (ESR-1917), or approved equal with a current ICC/IAPMO evaluation report. Screw anchors shall be Simpson Titen HD (ESR-2713) or approved equal with a current ICC/IAPMO evaluation report.
  3. Inserts
    - a. HILTI HIS-N Inserts (ESR-3187 or approved equal): ASTM A193 Grade B7 cap bolts and ASTM A194 nut, galvanized per ASTM A153 Class C or D.
    - b. HILTI HIS-RN Inserts (ESR-3187 or approved equal): ASTM A193 Grade B8M stainless steel bolts and ASTM F594 nut. Nuts shall be the same alloy group as the bolt.
- D. Cast-In-Place Anchors:
  1. Anchor Rods and Nuts: ASTM F1554 Grade 36 Class 2A (Grade 105 Class 2A where High Strength is noted) with matching finish ASTM A563 nuts. Rods embedded in concrete, grout or adhesive shall be galvanized or non-lubricated unless noted otherwise. Embedded rods shall be threaded full length unless noted otherwise. Rods, nuts and washers in contact with preservative-treated wood shall be hot-dipped galvanized.

## **2.08 BONDING AND JOINTING PRODUCTS**

- A. Epoxy Bonding System: Epoxies shall be a two component material for use on dry or damp surfaces and shall conform to the requirements of ASTM C881. Epoxy bonding agents and adhesives shall be used in strict accordance with manufacturer's recommendations.
  1. Acceptable Products subjected to compliance with requirements:
    - a. Sikadur Armatec 110; Sika Chemical Corporation or approved equal.

- B. Joint Filler: 1/2 inch thick unless noted on the Contract Drawings or approved shop drawings, with removable top section that will form 1/2 inch deep sealant pocket after removal.

**2.09 CURING MATERIALS**

- A. Curing Compound, Naturally Dissipating: Clear, water-based, liquid membrane-forming compound, that dissipates within 3 to 5 weeks; complying with ASTM C309.
- B. Curing and Sealing Compound, Low Gloss: Liquid, membrane-forming, clear, non-yellowing acrylic; complying with ASTM C1315 Type 1 Class A.
- C. Curing and Sealing Compound, High Gloss: Liquid, membrane-forming, clear, non-yellowing acrylic; complying with ASTM C1315 Type 1 Class A.
- D. Moisture-Retaining Sheet: ASTM C171.

**2.10 CONCRETE MIX DESIGN**

- A. Admixtures: Where admixtures are used they shall be added as recommended in ACI 211.1 for normal weight concrete and at rates recommended by manufacturer. Admixtures are subject to VTA's review.
- B. Fiber Reinforcement: Add to mix at rate of 1.5 pounds per cubic yard, or as recommended by manufacturer for specific project conditions.
- C. Normal Weight Concrete Mix Requirements:
  - 1. Shall be made with aggregates for hardrock concrete.
  - 2. Minimum Compressive Strength,  $f'_c$ , when tested in accordance with ASTM C39 at 28 days: As scheduled below.
  - 3. Minimum Cementitious Material Content:
    - a. For concrete ( $f'_c = 3000$  psi and greater) used in floors and slab-on-grades, cementitious material content shall not be less than indicated in the following table:

Nominal Maximum Size of Aggregate, in.	Minimum Cementitious Material Content, sacks
1.5	5
1	5.5
3/4	6
1/2	6.5

- 4. Maximum Water-Cement Ratio: As scheduled below. Significant volume of liquid admixtures should be considered as part of the mixing water.
- 5. Maximum Aggregate Size: Nominal maximum size of coarse aggregate shall not exceed three-fourths of the minimum clear spacing between reinforcing bars, one-fifth of the

narrowest dimension between sides of forms, or one-third of the thickness of slabs or toppings.

<b>Maximum Water/Cementitious Material Ratio</b>			
<b>Concrete Class</b>	<b>Minimum 28-day Compressive Strength f'c</b>	<b>Non-Air Entrained</b>	<b>Air Entrained</b>
Class D	3000 psi	0.55	0.55
Class F	2000 psi	0.67	0.62
Lean Concrete (CLSM)	300 psi		

**D. Structural Lightweight Concrete Mix Requirements:**

1. Shall be made with light weight aggregates conforming to ASTM C330. Lightweight aggregate must be presoaked per ACI 304.2.
2. Minimum Compressive Strength, f'c, when tested in accordance with ASTM C330 at 28 days: As scheduled above.
3. Minimum Cementitious Material Content: Same as normal weight concrete.
4. Maximum Water-Cement Ratio: As scheduled above. Significant volume of liquid admixtures should be considered as part of the mixing water.
5. Maximum Aggregate Size: Same as normal weight concrete but not greater than 3/4 inch.
6. Maximum dry unit weight: 120 lb per cubic foot as determined by ASTM C567.

**E. Controlled Low Strength Material (CLSM) Mix Requirements:**

1. Shall be made with aggregates conforming to ASTM C33.
2. Minimum Compressive Strength, f'c, when tested in accordance with ASTM D4832 at 28 days: As scheduled above.
3. Minimum Cement Content: 2 sacks.
4. Maximum Water-Cement Ratio: Sufficient to produce a fluid workable mixture without segregation of the aggregate when placed.

**F. Concrete Mix Designs:** The following table presents a schedule of classes of concrete, maximum aggregate, maximum slump and air content for each type of concrete, which shall be as follows:

<b>Concrete Element</b>	<b>Class of Concrete</b>	<b>Max. Size Aggregate</b>	<b>Max. Slump (inch) at point of discharge</b>
Foundation Walls and footings	D	1.5	3
Slabs on Grade	D	1	4

Structural Backfill	Lean	1.5	6
Yard Concrete Walks & Curbs	F	3/4	4

- G. Determine the slump by ASTM C143 at the point of truck discharge. Slump shall not exceed 3" for any concrete placement where top of surface slopes more than 2%. When use of a Type I or II plasticizing admixture conforming to ASTM C1017 or when a Type F or G high-range water-reducing admixture conforming to ASTM C494 is permitted to increase the slump of concrete, concrete shall have a slump of 2 to 4 in. before the admixture is added and a maximum slump of 8 in. at the point of truck discharge after the admixture is added unless otherwise specified.
- H. Add an air entraining agent to the concrete to provide specified amounts of entrained air per table below unless noted otherwise. Measure air content at the point of delivery in accordance with ASTM C173. Tolerance is plus/minus 1.5%. For specified compressive strengths above 5000 psi, the air contents indicated in the following table may be reduced by 1%.

Nominal Maximum Aggregate Size (Inches)	Air Content (Percent)	
	Exposure Class F1	Exposure Classes F2 and F3
3/8	6	7.5
1/2	5.5	7
3/4	5	6
1	4.5	6
1.5	4.5	5.5

### 2.11 MIXING

- A. Use ready-mixed concrete complying with ASTM C94 and with the requirements of Contract Documents. Mix for a period of not less than ten (10) minutes; at least three (3) minutes of the mixing period shall be immediately prior to discharging at the job.
- B. CLSM shall be placed in the work within 3 hours after introduction of the cement to the aggregates.

## PART 3 – EXECUTION

### 3.01 EXAMINATION

- A. Verify lines, levels, and dimensions before proceeding with work of this section.

### 3.02 PREPARATION (RESERVED)

### **3.03 WEATHER REQUIREMENTS**

- A. Reinforcement, forms and ground which concrete will contact shall be completely free of frost.
- B. When the average of the highest and lowest temperature during the period from midnight to midnight is expected to drop below 40° F for more than three successive days, deliver concrete to meet the following minimum temperatures immediately after placement:
  - 1. 55° F for sections less than 12 in. in the least dimension;
  - 2. 50° F for sections 12 to 36 in. in the least dimension;
  - 3. 45° F for sections 36 to 72 in. in the least dimension; and
  - 4. 40° F for sections greater than 72 in. in the least dimension.

The temperature of concrete as placed shall not exceed these values by more than 20° F. These minimum requirements may be terminated when temperatures above 50° F occur during more than half of any 24 h duration.

- C. The temperature of concrete as placed shall not exceed 90° F. When temperature of steel reinforcement, embedments, or forms is greater than 120° F, fog steel reinforcement, embedments, and forms with water immediately before placing concrete. Remove standing water before placing concrete.
- D. Do not begin to place or continue to place concrete while rain, sleet, or snow is falling unless adequate protection is provided and, when required, acceptance of protection is obtained. Do not allow rain water to increase mixing water or to damage the surface of the concrete.

### **3.04 CONVEYING AND PLACING CONCRETE**

- A. All concrete shall be mixed, delivered and discharged in accordance with the requirements of ASTM C94. All concrete shall be placed, finished and cured and all other pertinent construction practices shall be in accordance with the requirements of ACI 301.
- B. Notify VTA not less than two working days prior to commencement of placement operations.
- C. Before placing, clean mixing and conveying equipment, clean forms and space to be occupied by concrete and wet forms. Remove ground water until completion of work.
- D. Place no concrete in any unit of work until all formwork has been completely constructed, all reinforcements secured in place, all items to be built into concrete are in place, form ties at constructions joints tightened and all preparation have been checked by the Inspector. A placing record shall be kept on the site of the time and date of placing the concrete in each portion of the structure until the completion of the structure and shall be open to the Inspector.
- E. Slabs and beams shall not be subjected to occupant or storage loads exceeding 20 psf until specified strength is reached (28 days minimum).
- F. Concrete shall be placed so that a uniform appearance of surfaces will be obtained. The concrete will be free of all rock pockets, honeycombs and voids.
- G. The subgrade must be moist when the concrete is placed for floor slab to prevent excessive loss of water from the concrete mix.

- H. Pumping of concrete may require admixtures to increase slump beyond the maximum slump listed. Admixtures are subject to VTA's review.
- I. Carry on concreting, once started, as a continuous operation until the section of approved size and shape is completed. Make pour cut-offs of approved detail and location.
- J. Handle concrete as rapidly as practicable from mixer to place of deposit by methods which prevent separation or loss of ingredients. Deposit as nearly as practicable in final position to avoid rehandling or flowing. Do not drop concrete freely where reinforcing bars will cause segregation, impact the soil face of excavations nor drop freely more than eight feet. Use hoppers, chutes or trunks of varying length so that the free unconfined fall of concrete shall not exceed eight feet. Deposit to maintain a plastic surface approximately horizontal. In walls, deposit in horizontal layers not over eighteen inches deep. In pouring columns, walls or thin sections of considerable heights, use openings in forms, elephant trunks, tremies or other approved devices which permit concrete to be placed without segregation or accumulation of hardened concrete on forms or metal reinforcement above the level of the concrete. Install so concrete will be dropped vertically.
- K. Consolidating: All concrete shall be placed with mechanical vibration unless noted otherwise. Employ as many vibrators and tampers as necessary to secure the desired results. Minimum: one per each 20 cubic yards of concrete placed per hour. Eliminate the following practices: Pushing of concrete with vibrator; external vibration of forms; allowing vibrator to vibrate against reinforcing steel where steel projects into green concrete; allowing vibrator to vibrate contact faces of forms. Vibrators shall function at a minimum frequency of 3600 cycles per minute when submerged in concrete. Supplement vibration by forking and spading along the surfaces of the forms and between reinforcing whenever flow is restricted. Drilled piers shall be vibrated only to a depth of 3 times the pier diameter measured from the top of pier.

### **3.05 SLAB JOINTING**

- A. Saw Cut Control Joints: Saw cut joints with the Soff-Cut system or approved equal as soon as the surface is firm enough so that it will not be damaged by the blade, usually within 2 to 4 hours after placing; use 3/16 inch thick blade and cut at least 1 inch deep but not less than one quarter (1/4) the depth of the slab.

### **3.06 FLOOR FLATNESS AND LEVELNESS TOLERANCES**

- A. An independent testing agency, hired by the contractor, will inspect finished slabs for conformance to specified tolerances.
- B. Maximum Variation of Surface Flatness
  - 1. 1/4 inch in 10 ft in accordance with the "10-ft straight edge method" in ACI 117.
  - 2. Correct the slab surface if minimum 10% of the data samples are greater than 1/4 inch or if some data are not less than 3/8 inch.

### **3.07 CONSTRUCTION JOINTS**

- A. Location and details of construction joints shall be as indicated on Contract Drawings, approved shop drawings, as otherwise specified herein, or as approved by VTA. Locate so as not to impair the strength of the structure.



- B. Sandblast all construction joints using coarse sand or waterblast to clean and roughen entire surface of joint to 1/4 inch amplitude at all construction joints unless noted otherwise, exposing coarse aggregate solidly embedded in mortar matrix uniformly. Clean forms and reinforcing of drippings. Clear away debris by compressed air.

### **3.08 CONCRETE FINISHING**

- A. Finishing Formed Surfaces: Finish per requirements of ACI 301.
  - 1. Use grout-cleaned finish for permanently exposed formed surfaces except foundation surfaces and smooth-rubbed finish for exposed foundation surfaces.
- B. Finishing Unformed Surfaces: Steel trowel finish. Start finishing after bleeding of concrete is finished. The presence of bleed water is detected visually but when concrete surface is getting dry fast and rate of evaporation is so high, place a clear plastic sheet over a section of the concrete to block evaporation and to allow observation of bleeding.
- C. Measure slabs for suspended floors and slabs-on-ground to verify compliance with the tolerance requirements of ACI 117 as specified below:
  - 1. For nonresidential floor installations 10,000 square foot or less in total project area and for residential floors, 1/4 inch in 10 ft in accordance with the "10-ft straight edge method" in ACI 117.
  - 2. For nonresidential floor installations exceeding 10,000 square foot in total project area, FF=35 and FL=25 in accordance with ASTM E 1155 and the F-number system in ACI 117. FL applies only to level slabs on grade or level suspended slabs that are shored when tested.

### **3.09 CURING AND PROTECTION**

- A. Comply with requirements of ACI 301. Immediately after placement, protect concrete from premature drying, excessively hot or cold temperatures, and mechanical injury.
- B. Maintain concrete with minimal moisture loss at above 50° F for the period of time necessary for hydration of cement and hardening of concrete.
  - 1. Normal concrete: At least the first 7 days after placement.
  - 2. High early strength concrete: At least the first 3 days after placement.
- C. Curing methods shall comply with ACI 308R.
- D. Curing compounds conforming to ASTM C309 or ASTM C1315 shall be applied in accordance with the recommendations of the manufacturer and shall not be used on any surface against which additional concrete or other cementitious finishing materials are to be bonded, where epoxy flooring is called for, where concrete topping is to receive waterproofing membrane, where not recommended by integral color maker, nor on surfaces where such curing is prohibited by the project specifications.
- E. Unformed concrete surfaces: Start curing as soon as the bleed water sheen has disappeared and before surface is dry.
  - 1. Initial Curing: If surface drying starts before initial set of concrete, keep concrete continuously moist up to final set of concrete by fog spray. Time of initial set is also known as the vibration limit where concrete cannot be properly consolidated after reaching

initial set. Before initial set, the concrete is not stiff enough to support the weight of a finisher or finishing machine. Water from fogging should be removed or allowed to evaporate before finishing.

2. Final Curing: Begin immediately after finishing. If finishing is completed but concrete has not reached final set, keep concrete continuously moist by fog spray, a liquid-applied evaporation reducer spray, or liquid membrane-forming curing compound spray. Water from fogging should be removed or allowed to evaporate before finishing. After final set of concrete, curing shall be accomplished by one of the following materials or method:
  - a. Ponding, continuous fogging, or continuous sprinkling;
  - b. Application of a curing compound.
  - c. Application of mats or fabric kept continuously wet.
  - d. Application of moisture-retaining sheet conforming to ASTM C171.
  - e. Other moisture-retaining covering as reviewed by Architect.
- F. Formed concrete surfaces: Steel forms and all wood forms in contact with the concrete shall be kept wet until they are removed. After formwork removal cure concrete by one of the method in final curing.
- G. Remove protection in such a manner that the maximum decrease in temperature measured at the surface of the concrete in a 24 hr period shall not exceed the following:
  1. 50° F for sections less than 12 in. in the least dimension;
  2. 40° F for sections from 12 to 36 in. in the least dimension;
  3. 30° F for sections 36 to 72 in. in the least dimension; or
  4. 20° F for sections greater than 72 in. in the least dimension.
- H. Measure concrete temperature using a method acceptable to VTA, and record the concrete temperature. When the surface temperature of the concrete is within 20° F of the ambient or surrounding temperature, protection measures may be removed.

### **3.10 PATCHING AND CLEANING**

- A. After forms are removed, remove projecting fins, form ties, nails, etc. not necessary for the work or cut back one inch from the surface. Joint marks and fins in exposed work shall be smoothed off and cleaned as directed by VTA.
- B. Repair defects in concrete work as directed by VTA and per ACI 301. Chip voids and stone pockets to a depth of one inch or more as required to remove all unsound material. Voids, surface irregularities, chipped areas, etc., shall be filled by patching, gunite or rubbing, as directed by VTA. Repaired surfaces shall duplicate appearance of unpatched work.
- C. Clean exposed concrete surfaces and adjoining work stained by leakage of concrete to approval of VTA.

### **3.11 CLEANUP**

- A. Clean up all concrete and cement work on completion of this portion of the work, except protective coatings or building papers shall remain until floors have completely cured or until interior partitions are to be installed.

### **3.12 GROUTING**

- A. Column base plates: The grout shall be mixed and placed in strict accordance with manufacturer's instructions. Care shall be taken in the grouting to ensure that there are no voids or air pockets, and that there is full bearing between the base plates and the grout.
- B. Bearing plates and channels: The space between plates and channels bearing against masonry or concrete shall be filled with grout when required by VTA. The grout shall be mixed and placed in strict accordance with manufacturer's instructions. Care shall be taken in the grouting to ensure that there are no voids or air pockets, and that there is full bearing between the bearing plates and channels and the grout.

### **3.13 POST INSTALLED ANCHORS**

- A. Anchor minimum edge distances defined by the current ICC/IAPMO evaluation report shall be met at edges, control joints and cracks greater than 0.015 inches wide. Installation of anchors and adhesive including drilling, cleaning of holes and torque shall be in accordance with the current ICC/IAPMO evaluation report. Verify whether the evaluation report requires a maximum or minimum torque. Confirm torque with a torque wrench calibrated to the inspector's torque wrench. Post installed anchors shall be used only in applications permitted by the Evaluation Report. Anchors shall use washer sized to prevent crushing of the attached member at installation torque.
- B. Provide stainless steel anchors for exterior use or when expose to weather or in chemically corrosive environments. Provide galvanized carbon steel anchors at other locations unless noted otherwise on the Contract Drawings or approved shop drawings.
- C. If reinforcement is encountered during drilling, abandon and shift the hole location to avoid the reinforcement. Provide a minimum of 2 anchor diameters or 1 inch, whichever is larger, of sound concrete between the anchor and the abandoned hole. Fill the abandoned hole with non-shrink grout. If the anchor or dowel may not be shifted as noted above, VTA will determine a new location.
- D. Refer to Contract Drawings for additional inspection and testing requirements.
- E. Adhesive Anchors:
  - 1. Adhesive anchoring system in concrete shall be HILTI-HY 200 (ESR-3187) or approved equal with a current ICC/IAPMO evaluation report.
  - 2. Insert the anchor or dowel in the hole with a twisting motion to the required embedment depth. Do not pump the anchor or dowel in and out of the hole.
  - 3. Wedge bars tight and centered in the hole with wooden wedges (golf tees) to hold it in place until the adhesive sets.

F. Expansion Anchors:

1. Install per the ICC/IAPMO report to the nominal embedment depth shown on the plans. Tightening of the anchor shall not reduce the embedment below that specified on the plans by more than eight threads. Projecting portions of the anchor shall not be cut off before inspection is complete.
2. Expansion anchors shall be HILTI KWIK BOLT-TZ (ESR-1917), or approved equal with a current ICC/IAPMO evaluation report.

**3.14 FIELD QUALITY CONTROL**

- A. VTA shall inspect the surfaces between plates and channels bearing on masonry and concrete to determine if grouting of space is necessary. If grouting of space is necessary, VTA shall inspect the grouting procedure.
- B. Acceptance of concrete strength is in accordance with ACI 318 section 5.3 unless noted otherwise. Conduct all testing required to demonstrate concrete complies with compressive strength requirements.
- C. When the strength of field-cured cylinders is less than 85% of companion laboratory-cured cylinders, evaluate current operations and provide corrective procedures for protecting and curing in-place concrete.
- D. Field Acceptance of concrete: Concrete not within the specified limits of air-entrainment, slump and temperature shall not be used in the work.
- E. Additional Tests: Contractor will make additional tests of in-place concrete when test results indicate specified concrete strengths and other characteristics have not been attained in the structure or deficiencies in protection and curing has occurred, as directed by VTA. Contractor may conduct tests to determine adequacy of concrete by cored cylinders complying with ASTM C42, or by other methods as directed. Contractor must pay for such tests conducted, other additional testing as may be required, and for the cost of repairing areas of structure tested when unacceptable concrete is verified, all with no additional charge to VTA.

**3.15 DEFECTIVE CONCRETE**

- A. General: Work considered to be defective may be ordered by VTA to be replaced in which case the Contractor shall remove the defective work at its expense. Work considered to be defective shall include, but not be limited to, the following:
  1. Concrete in which defective or inadequate reinforcing steel has been placed.
  2. Concrete incorrectly formed, or not conforming to details and dimensions on the Contract Drawings, approved shop drawings, or with the intent of the Technical Specifications, or concrete the surfaces of which are out of plumb or level.
  3. Concrete below specified strength.
  4. Concrete not meeting the maximum allowable drying shrinkage requirements.
  5. Concrete containing wood, cloth, or other foreign matter, rock pockets, voids, honeycombs, cracks or cold joints not scheduled or indicated on the Contract Drawings, or approved shop drawings.

**3.16 CORRECTION OF DEFECTIVE WORK**

- A. Contractor shall, at its expense, make all such corrections and alleviation measures as directed by VTA.
- B. Concrete work containing rock pockets, voids, honeycombs, cracks or cold joints not scheduled or indicated on the Contract Drawings or approved shop drawings, shall be chipped out until all unconsolidated material is removed.
- C. Secure approval of chipped-out areas before patching. Patch per ACI 301-latest governing edition.

**END OF SECTION 03 30 00**

*[This Page Intentionally Left Blank]*

**DIVISION 9 – FINISHES**  
**SECTION 09 91 23 – PAINTING**

**PART 1 – GENERAL**

**1.01 SECTION INCLUDES**

- A. Surface preparation and field application of paints.
  - 1. Surface preparation, priming, and coats of paint specified are in addition to priming and surface treatments specified under other Technical Specifications Sections.
  - 2. The intent of this Technical Specifications Section is for ALL new items furnished and installed in this Contract to be painted, unless indicated otherwise.
  - 3. The term “paint” as used herein means all coating systems materials, and includes primers, emulsions, acrylics, enamels, stain, sealers and fillers, and other applied materials whether used as prime, intermediate, or finish coats.

**1.02 RELATED SECTIONS**

- A. Technical Specifications **Section 01 73 00 – Execution**, for cutting and patching requirements at lead containing paint locations.

**1.03 SUBMITTALS**

- A. Submittal procedures must be in accordance with the applicable provisions of:
  - 1. **Section 6.6 Contract Data Requirements**
  - 2. **Section 7.41 Product Options, Supplier Approval and Substitutions**
  - 3. **Section 7.43 Submittal of Shop Drawings, Product Data and Samples**
  - 4. **Section 7.49.1 Certificate of Compliance**
  - 5. **Appendix B Contract Data Requirements**
- B. Product data: Provide data on all finishing products and special coatings, including VOC content.
- C. Samples: Submit painted samples, illustrating selected colors and sheen for each color and system selected. Submit on aluminum sheet, 8 x 10 inch in size.

**1.04 QUALITY ASSURANCE**

- A. Manufacturer qualifications: Nationally recognized company specializing in manufacturing the products specified, with minimum ten years documented experience.
- B. Paint coordination for factory applied primer:
  - 1. Provide finish coats that are fully compatible with the prime coatings used. Field-applied primers shall be supplied by the same manufacturer as the finish coats used. Review other Technical Specifications sections in which prime paints are specified to ensure compatibility of the coating system for each of the various substrates. Provide barrier coats over incompatible primers or remove and re-prime as required.

- C. Use only materials which comply with Bay Area Air Quality Management District regulations.

#### **1.05 DELIVERY, STORAGE, AND HANDLING**

- A. Deliver products to work site in sealed and labeled containers.
- B. Container label: Include manufacturer's name, type of paint, brand name, lot number, brand code, coverage, surface preparation, drying time, cleanup requirements, color designation, and instructions for mixing and reducing.
- C. Establish and maintain storage area conditions for paints and materials in accordance with manufacturer's written specifications. Store solvent-based paints and materials, in accordance with requirements of authorities having jurisdiction.

#### **1.06 FIELD CONDITIONS**

- A. Follow manufacturer's recommended procedures for producing best results, including testing of substrates, moisture in substrates, and humidity and temperature limitations, and the following:
  - 1. Maintain ambient temperature above 40 degrees F. during and 24 hours after installation.
  - 2. Apply water-borne paints when the temperature of surfaces to be painted and surrounding air temperature is between 50 degrees F. and 90 degrees F. Apply solvent-thinned paints only when the temperature of surfaces to be painted and the surrounding air temperature is between 45 degrees F. and 95 degrees F. Do not apply paints in precipitation, fog or mist, when relative humidity exceeds 85 percent, or at temperatures less than 5 degrees F. above dew point, or to damp or wet surfaces.
- B. Contractor is fully responsible for the controlling of over-spray and work environment during the application of all field applied paints.

#### **1.07 EXTRA STOCK**

- A. None required.

### **PART 2 – PRODUCTS**

#### **2.01 MANUFACTURERS**

- A. Kelly Moore numbers for Kelly-Moore products are specified in order to establish a quality standard for this project. It is understood such references are used to facilitate the description of the product and is deemed to be followed by the words "or approved equal".
- B. Acceptable manufacturers:
  - 1. Kelly Moore, Dunn Edwards, Sherwin Williams, or approved equal.
- C. Provide all paint and coating products used in each paint system from the same manufacturer. A paint system is defined to be all coats of all materials applied to any given surface area.
- D. Provide primers which are suitable for each surface to be painted and which are compatible with specified intermediate and finish coats.

#### **2.02 PAINTS AND COATINGS - GENERAL**

- A. Paints and coatings:



1. Materials for use within each paint system must be compatible with one another and substrates indicated.
  2. Supply each coating material in quantity required to complete entire Contract Work from a single production run.
  3. Materials for primers and finish coats of paint must be ready-mixed and must not be changed. Do not reduce, thin, or dilute coatings or add materials to coatings unless such procedure is performed as specifically described in manufacturer's product instructions.
- B. Use manufacturer's highest quality products suitable for intended use, categorized as "best" or "premium" by the manufacturer.
- C. Volatile Organic Compound (VOC) content for interior paint: Comply with VOC content restrictions of authorities having jurisdiction.
- D. Colors: To be selected by VTA from manufacturer's full range of available colors.
1. Color selection to be made by VTA after award of Contract.
  2. All exposed pipes and conduits, Unistrut, hangers and supporting hardware, shall be the same color as the surface they are mounted on/under.

### **2.03 PAINT SYSTEMS**

- A. Ferrous Metal (Shop primed):
1. Alkyd Primer (for spot priming): 1760-120 Shop Coat Primer Red, or 1760-190 Shop Coat Primer Grey.
  2. Finish: Two (2) coats of 5885 Series DTM Acrylic Semi-Gloss Enamel. DFT (Dry): 1.7 – 2.2 mils per coat.
- B. Ferrous Metal (Not shop primed)
1. Primer: One (1) coat of 5725 Series DTM Acrylic Metal Primer. DFT (Dry): 1.6 – 2.0 mils per coat.
  2. Finish: Two (2) coats of 5885 Series DTM Acrylic Semi-Gloss Enamel. DFT (Dry): 1.6 – 2.2 mils per coat.
- C. Galvanized Metal:
1. Primer: One (1) coat of 5725 Series DTM Acrylic Primer. DFT (Dry): 1.6 – 2.0 mils per coat.
  2. Finish: Two (2) coats of 5885 Series DTM Acrylic Semi-Gloss Enamel. DFT (Dry): 1.6 – 2.2 mils per coat.
- D. Concrete and Masonry:
1. Primer: One (1) coat of 247 AcryShield Acrylic Masonry Primer. DFT (Dry): 1.5 – 2.0 mils per coat.
  2. Finish: Two (2) coats of 1247 AcryShield Acrylic Satin Enamel. DFT (Dry): 1.6 – 2.0 mils per coat.

E. PVC:

1. Primer: One (1) coat of 295 Kel-Bond Acrylic Universal Primer. DFT (Dry): 1.5 – 2.0 mils per coat.
2. Finish: Two (2) coats of 1250 AcryShield Acrylic Semi-Gloss Enamel. DFT (Dry) 1.6 – 2.2 mils per coat.

**2.04 ACCESSORY MATERIALS**

- A. Accessory materials: Provide all primers, sealers, cleaning agents, cleaning cloths, sanding materials, and clean-up materials required to achieve the finishes specified whether indicated or not; commercial quality.
- B. Patching material: 3M Acryl-Red Glazing Putty, Bondo Glazing and Spot Putty, or approved equal.
- C. Fastener head cover material: 3M Acryl-Green Spot Putty, Bondo Glazing and Spot Putty, or approved equal.

**PART 3 – EXECUTION**

**3.01 EXAMINATION**

- A. Do not apply paint in areas where dust is being generated.
- B. Do not begin application of coatings until substrates have been properly prepared.
- C. Verify that surfaces are ready to receive Work as instructed by the product manufacturer.
- D. Examine surfaces scheduled to be finished prior to commencement of Work. Report any condition that may potentially affect proper application.
- E. Notify VTA immediately if substrate preparation is unsatisfactory to receive coatings before proceeding.

**3.02 PROTECTION OF ITEMS NOT TO BE PAINTED**

- A. Remove, mask, or otherwise protect hardware, lighting fixtures, switchplates, aluminum surfaces, nameplates on machinery, and other surfaces not specified elsewhere to be painted.
- B. Furnish sufficient drop cloths, shields and protective equipment to prevent overspray or droppings from marring adjacent surfaces.
- C. Protect mechanical and electrical equipment in the shop building from damage during surface preparation and painting process.

**3.03 PREPARATION**

- A. Clean substrates of substances that could impair bond of paints, including dust, dirt, oil, grease and incompatible paints.
- B. Comply with manufacturer's written instructions for preparation of substrates.
- C. Steel, Ferrous Metal Substrates, not shop primed:
  1. Remove rust, loose mill scale. Clean using methods recommended in writing by paint manufacturer, but not less than the following:

- a. SSPC-SP 3, "Power Tool Cleaning"
  2. Use hand tools to clean areas that cannot be cleaned by power tool cleaning.
  3. Follow paint manufacturer's written instructions for additional preparation that may be required.
- D. Steel, Ferrous Metal Substrates, shop primed:
  1. Clean field welds, bolted connection, and abraded areas of shop paint, and paint exposed areas with the same material as used for shop priming to comply with SSPC-PA 1, "Shop, Field, and Maintenance Painting of Steel" for touching up shop-primed surfaces.
  2. Follow paint manufacturer's written instructions for additional preparation that may be required.
- E. Galvanized Metal Substrates:
  1. Remove grease and oil residue from galvanized sheet metal by mechanical methods to produce clean, lightly etched surfaces that promote adhesion of subsequently applied paints.
  2. Repair damaged surfaces with galvanizing repair material in accordance with ASTM A780.
  3. Follow paint manufacturer's recommendations for additional preparation that may be required.
- F. Aluminum Substrates: Remove loose surface oxidation.
- G. Concrete Surface Preparation:
  1. Do not begin until 30 days after concrete has been placed.
  2. Remove grease, oil, dirt, salts or other chemicals, loose materials, or other foreign matter by solvent, detergent, or other suitable cleaning methods.
  3. Follow paint manufacturer's recommendations for additional preparation that may be required.
- H. Existing Painted Surfaces to be Repainted Surface Preparation:
  1. Detergent wash and freshwater rinse.
  2. Feather into surrounding intact coating.
  3. Apply one spot coat of specified primer to bare areas, overlapping prepared existing coating.

### **3.04 APPLICATION**

- A. Apply products in accordance with manufacturer's instructions.
- B. Do not apply finishes to surfaces that are not dry. Allow applied coats to dry before next coat is applied.
- C. Apply by brush or roller, except for materials specifically required by manufacturer to be applied by spraying. Spray application in existing occupied spaces only upon acceptance by VTA. In existing occupied spaces where paint is applied by spray, mask or enclose with polyethylene, or similar air tight material with edges and seams continuously sealed.

1. The number of coats and film thickness required is the same regardless of application method.
2. Apply each coat to uniform appearance.
3. Use tack cloth to remove dust and particles just prior to applying next coat.
4. Paint surfaces behind movable equipment same s similar exposed surfaces. Before final installation, paint surfaces behind permanently fixed equipment with prime coat only.
5. Primers specified in application schedules may be omitted on items that are factory primed if acceptable to topcoat manufacturers.
6. If undercoats or other conditions show through topcoat, apply additional coats until cured film has a uniform paint finish, color, and appearance.
7. Apply paints to produce surface films without cloudiness, spotting, laps, brush marks, roller tracking, runs, rags, or other surface imperfections.

### **3.05 APPLICATION SCHEDULE**

- A. Items to be painted:
- a. All steel and miscellaneous metals furnished and installed in this Contract, such as framing members, plates, angles, brackets and hardware, exposed to view.
  - b. All sheet metal and flashing installed in this contract.
  - c. All metal and plastic piping and conduit furnished and installed in this Contract, exposed to view.
  - d. All conduit fittings and supports furnished and installed in this Contract, such as Unistrut, framing channels, threaded rods, and hardware, exposed to view.
  - e. All mechanical, plumbing, electrical equipment furnished and installed in this Contract, such as enclosures, panelboards and switch gear, exposed to view.
  - f. Existing wall surfaces uncovered due to openings required to be cut or removed for installation of new work. Feather into adjacent surfaces.
  - g. Existing steel uncovered due to cutting or repairing required for installation of new work. Feather into adjacent surfaces.
  - h. Existing surfaces uncovered due to removal of existing items, such as conduit and supports, electrical boxes, lighting fixtures and equipment removal. Feather into adjacent surfaces.
  - i. All items furnished and installed in this Contract having hot-dipped galvanized surfaces.
  - j. All items furnished and installed in this Contract having prime coats applied in shop under other specification Sections. Work shall include touching up of or repairing abraded, damaged or rusted prime coats.
  - k. Prime painting of all unprimed items furnished and installed in this Contract which require prime painting.

- I. All incidental painting and touch up required to produce proper finish for painted surfaces, including touching up of factory finished items furnished and installed in this Contract.
- B. Do not paint the following:
  1. Existing items, except as indicated in the application schedule above.
  2. Items factory finished.
  3. Stainless steel.
  4. Anodized aluminum.
  5. Equipment nameplates, fire rating labels and operating parts of equipment.
  6. Concealed piping.
  7. Concealed conduit.
  8. Concrete floors.

**3.06 CLEAN UP**

- A. Collect cloth waste material that could constitute a fire hazard, place in closed metal containers, and remove daily from Jobsite.
- B. Remove paint spots and stains from adjacent surfaces and floors.

**3.07 PROTECTION**

- A. Protect work of other trades, whether being painted or not, against damage from painting. Correct damage by cleaning, repairing or replacing, and repainting, as approved by Architect.
- B. Provide "Wet Paint" signs to protect newly painted finishes. After completing painting operations, remove temporary protective wrappings provided by others to protect their work.
- C. After work of other trades is complete, touch up and restore damaged or defaced painted surfaces.

**END OF SECTION 09 91 23**

*[This Page Intentionally Left Blank]*

**DIVISION 23 – HEATING & VENTILATION AND AIR CONDITIONING**  
**SECTION 23 11 26 – FACILITY LIQUEFIED-PETROLEUM GAS PIPING**

**PART 1 – GENERAL**

**1.01 SUMMARY**

- A. Section Includes:
1. Pipes, tubes, and fittings.
  2. Piping specialties.
  3. Piping and tubing joining materials.
  4. Valves.
  5. Pressure regulators.
  6. Transport truck unloading facility specialties.
  7. Vaporizers.

**1.02 RELATED SECTIONS**

- A. Technical Specifications Section 23 13 23 – Facility Aboveground LPG Fuel Storage Tanks

**1.03 REFERENCES**

- A. American Society of Civil Engineers:
1. ASCE 7-16 – Minimum Design Loads for Building & Other Structures
- B. American Society of Mechanical Engineers:
1. ASME B16.3 - Malleable Iron Threaded Fittings.
  2. ASME B16.18 - Cast Copper Alloy Solder Joint Pressure Fittings.
  3. ASME B16.22 - Wrought Copper and Copper Alloy Solder Joint Pressure Fittings.
- C. American Society for Testing and Materials:
1. ASTM A53 - Standard Specification for Pipe, Steel, Black and Hot-Dipped, Zinc-Coated, Welded and Seamless.
  2. ASTM D2513-18a – Standard Specification for Polyethylene (PE) Gas Pressure Pipe, Tubing and Fittings.
- D. NACE International:
1. NACE RP-01-69 - Control of External Corrosion on Underground or Submerged Metallic Piping Systems.
- E. Codes:
1. NFPA 30 - Flammable and Combustible Liquids Code.
  2. NFPA 70, National Electric Code, 2016.

3. California Health and Safety Code, 2016.
4. California Fire Code, 2016.

#### **1.04 SUBMITTALS**

- A. Submittal procedures must be in accordance with the applicable provisions of:
  1. **Section 6.6 Contract Data Requirements**
  2. **Section 7.41 Product Options, Supplier Approval and Substitutions**
  3. **Section 7.43 Submittal of Shop Drawings, Product Data and Samples**
  4. **Section 7.49.1 Certificate of Compliance**
  5. **Appendix B Contract Data Requirements**
- B. Welding certificates
- C. Field quality-control test and inspection reports: Indicate and interpret test results for compliance with performance requirements.
- D. Product Data: For each type of product:
  1. Pipes, tubes, and fittings.
  2. Piping specialties.
  3. Joining Materials.
  4. Valves. Include pressure rating, capacity, settings, and electrical connection data of selected models.
    - a. Manual gas shutoff valves.
    - b. Earthquake valves.
  5. Pressure regulators. Indicate pressure ratings and capacities.
  6. Dielectric fittings.
  7. Transport truck unloading specialties.
  8. Vaporizers.
  9. Labeling and identifying materials, including detectable warning tape.
- E. Shop Drawings:
  1. For facility LPG piping layout. Include plans, piping layout and elevations, sections, and details for fabrication of pipe anchors, hangers, supports for multiple pipes, alignment guides, expansion joints and loops, and attachments of the same to building structure. Detail location of anchors, alignment guides, and expansion joints and loops.
  2. For vaporizers and related equipment layout and piping, including mounting or anchorage details.
  3. For transport truck unloading facility and appurtenances.



- F. LPG Piping fusion procedure.
- G. LPG cleaning & purging plan.
- H. Closeout Submittals
  - 1. Operation and maintenance data
    - a. Emergency procedures.
    - b. Operation and maintenance manuals.
    - c. Settings and calibration information.
    - d. Training & preventative maintenance manuals, with staff training sessions.
  - 2. Warranty Certificates.

#### **1.05 PERFORMANCE REQUIREMENTS**

- A. Minimum Operating-Pressure Ratings:
  - 1. For Piping Containing Only Vapor:
    - a. Piping and Valves: 125 psig unless otherwise indicated.
  - 2. For Piping Containing Liquid:
    - a. Piping between Shutoff Valves: 350 psig unless otherwise indicated.
    - b. Piping Other Than Above: 250 psig unless otherwise indicated.
    - c. Valves and Fittings: 250 psig unless otherwise indicated.
- B. LPG System Pressure within Buildings: Is controlled by the existing main line Pressure Regulator and secondary regulators if there is more than one pressure range within the building.
- C. Seismic Performance: Vaporizers shall withstand the effects of earthquake motions determined according to ASCE 7-16. Seismic anchorages shown in the Contract Drawings are designed based upon the basis of design vaporizers. Any suggested vaporizer substitutions from an acceptable manufacturer must fit within the current design of Work, meaning no changes to the current design will be necessary in order to accommodate the substitution.

#### **1.06 QUALITY ASSURANCE**

- A. Steel Support Welding Qualifications: Qualify procedures and personnel according to AWS D1.1/D1.1M, "Structural Welding Code - Steel."
- B. Pipe Welding Qualifications: Qualify procedures and operators according to ASME Boiler and Pressure Vessel Code. Provide a copy of certificates.
- C. Electrical Components, Devices, and Accessories: Listed and labeled as defined in NFPA 70, by a qualified testing agency, and marked for intended location and application.

#### **1.07 DELIVERY, STORAGE, AND HANDLING**

- A. Handling Flammable Liquids: Remove and dispose of liquids from existing LPG piping according to requirements of authorities having jurisdiction.

- B. Deliver pipes and tubes with factory-applied end caps. Maintain end caps through shipping, storage, and handling to prevent pipe end damage and to prevent entrance of dirt, debris, and moisture.
- C. Store pipes and tubes with protective PE coating to avoid damaging coating and protect from direct sunlight.
- D. Protect stored PE pipes and valves from direct sunlight.

#### **1.08 PROJECT CONDITIONS**

- A. Interruption of Existing LPG Service: Do not interrupt LPG service to facilities unless permitted under the following conditions and then only after arranging to provide purging and startup of LPG supply according to requirements indicated and specified in NFPA 56 (2017 edition) "STANDARDS FOR FIRE AND EXPLOSION PREVENTION DURING CLEANING AND PURGING OF FLAMMABLE GAS PIPING SYSTEMS".
  - 1. Contractor will be responsible for cleaning and purging the affected sections of the propane gas distribution system as required to safely complete the Work. Contractor must develop a written cleaning & purging plan including system de-pressurization, cleaning/purging, and re-pressurization sequence. The plan must include written procedures for each building, and should including the following items of information:
    - a. Work location and environmental conditions.
    - b. Communication plans.
    - c. Pre-purge piping system layout (with zoning if multiple zones will be purged separately).
    - d. Isolation and/or disconnection plan of the low pressure 0.5 psig (or below) appliance regulators to avoid physical damage and/or malfunction.
    - e. Monitoring and Instrumentation.
    - f. Potential Ignition sources and control.
    - g. Material list (Inert gas, air) of used cleaning/purging media.
    - h. Identify isolation points with means of isolation (disconnection, valves, caps etc.).
    - i. Max purge pressure cannot exceed the pipe and components max. operating pressure.
    - j. Discharging/venting plan for purging the gas.
    - k. Re-pressurization sequence plan.

The Cleaning and Purging Plan must be tailored to the specifics of this project and will be subject to VTA & AHJ review and approval.

- B. Notify VTA no fewer than fourteen (14) days in advance of proposed interruption of LPG service.
- C. Propane service must be maintained to the existing propane powered emergency backup power generators, until they have been decommissioned by VTA contract C19010, unless approved otherwise in writing by VTA.

- D. Do not proceed with interruption of LPG service without VTA's written permission.

#### **1.09 COORDINATION**

- A. Coordinate sizes and locations of concrete bases shown on Contract Drawings with actual equipment provided.

### **PART 2 – PRODUCTS**

#### **2.01 PIPES, TUBES, AND FITTINGS**

- A. Steel Pipe: ASTM A 53/A 53M, black steel, Schedules 40 and 80, Type E or S, Grade B.
1. Malleable-Iron Threaded Fittings: ASME B16.3, Class 150, standard pattern.
  2. Wrought-Steel Welding Fittings: ASTM A 234/A 234M for butt welding and socket welding.
  3. Unions: ASME B16.39, Class 150, malleable iron with brass-to-iron seat, ground joint, and threaded ends.
  4. Protective Coating for Underground Piping: Factory-applied, three-layer coating of epoxy, adhesive, and PE.
    - a. Joint Cover Kits: Epoxy paint, adhesive, and heat-shrink PE sleeves.
- B. Corrugated, Stainless-Steel Tubing: Comply with ANSI/IAS LC 1.
1. Application: Only allowable for applications with 0.5 psig or less, and NPS 1 or smaller.
  2. Manufacturers: Gastite, Menards, ProFlex, or approved equal.
  3. Tubing: ASTM A 240/A 240M, corrugated, Series 300 stainless steel.
  4. Coating: PE with flame retardant.
    - a. Surface-Burning Characteristics: As determined by testing identical products according to ASTM E 84 by a qualified testing agency. Identify products with appropriate markings of applicable testing agency.
      - 1) Flame-Spread Index: 25 or less.
      - 2) Smoke-Developed Index: 50 or less.
  5. Fittings: Copper-alloy mechanical fittings with ends made to fit and listed for use with corrugated stainless-steel tubing and capable of metal-to-metal seal without gaskets. Include brazing socket or threaded ends complying with ASME B1.20.1.
  6. Striker Plates: Steel, designed to protect tubing from penetrations.
  7. Manifolds: Malleable iron or steel with factory-applied protective coating. Threaded connections shall comply with ASME B1.20.1 for pipe inlet and corrugated tubing outlets.
  8. Operating-Pressure Rating: min. 5 psig.
- C. MDPE Pipe and Fittings: Comply with as follows:
1. Manufacturers: DRISCOPEX 6500 by Performance Pipe: ASTM D2513, NSF Gas and DOT 49 CFR 192, or approved equal.

2. HDPE Fittings PLASSON by Performance Pipe: ASTM D2513, F1055, F2897, and where applicable AWWA C906 product standards for electro-fusion type with dimensions matching MDPE pipe, or approved equal.
3. Transition Service-Line Risers: Factory fabricated, and leak tested.
  - a. Underground Portion: MDPE pipe complying with ASTM D 2513 (see above) connected to steel pipe complying with ASTM A 53/A 53M, Schedule 40, Type E or S, Grade B, with corrosion-protective coating for aboveground outlet.
  - b. Outlet shall be threaded suitable for welded connection.
  - c. Bridging sleeve over mechanical coupling.
  - d. Factory-connected anode.
  - e. Tracer wire connection.
  - f. Ultraviolet shield.
  - g. Stake supports with factory finish to match steel pipe casing or carrier pipe.
  - h. HDPE Transition (Mechanical Joint Adapter) Fittings PLASSON by Performance Pipe: Factory-fabricated fittings with HDPE pipe complying with ASTM D3261 and AWWA C901 & C906; and steel pipe complying with ASTM A 53/A 53M, black steel, Schedule 40, Type E or S, Grade B, or approved equal.

## **2.02 PIPING SPECIALTIES**

- A. Flexible Piping Joints:
  1. Approved for LPG service.
  2. Stainless-steel bellows with woven, flexible, bronze, wire-reinforcing protective jacket.
  3. Minimum working pressure of 250 psig and 250 deg F operating temperature.
  4. Threaded-end connections to match equipment connected and shall be capable of minimum 3/4-inch misalignment.
  5. Maximum 36-inch length for liquid LPG lines.
- B. Appliance Flexible Connectors:
  1. Indoor, Fixed-Appliance Flexible Connectors: Comply with ANSI Z21.24.
  2. Indoor, Movable-Appliance Flexible Connectors: Comply with ANSI Z21.69.
  3. Outdoor, Appliance Flexible Connectors: Comply with ANSI Z21.75.
  4. Corrugated stainless-steel tubing with polymer coating: comply with ANSI LC 1
  5. Operating-Pressure Rating: 0.5 psig.
  6. End Fittings: Zinc-coated steel.
  7. Threaded Ends: Comply with ASME B1.20.1.
  8. Maximum Length: 72 inches

- C. Y-Pattern Strainers:
  - 1. Body: ASTM A 126, Class B, cast iron with bolted cover and bottom drain connection.
  - 2. End Connections: Threaded ends for NPS 2 and smaller.
  - 3. Strainer Screen: 40-mesh startup strainer and perforated stainless-steel basket with 50 percent free area.
  - 4. CWP Rating: 125 psig.
- D. Weatherproof Vent Cap: Cast- or malleable-iron increaser fitting with corrosion-resistant wire screen, with free area at least equal to cross-sectional area of connecting pipe and threaded-end connection.

### **2.03 JOINING MATERIALS**

- A. Joint Compound and Tape: Suitable for LPG.
- B. Welding Filler Metals: Comply with AWS D10.12/D10.12M for welding materials appropriate for wall thickness and chemical analysis of steel pipe being welded.
- C. Brazing Filler Metals: Alloy with melting point greater than 1000 deg F complying with AWS A5.8/A5.8M.

### **2.04 MANUAL GAS SHUTOFF VALVES**

- A. See "Aboveground Manual Gas Shutoff Valve Schedule" Article for where each valve type is applied in various services.
- B. Metallic Valves, NPS 2 and Smaller for Liquid Service: Comply with ASME B16.33 and UL 842.
  - 1. CWP Rating: 250 psig.
  - 2. Threaded Ends: Comply with ASME B1.20.1.
  - 3. Socket ends for brazed joints.
  - 4. Tamperproof Feature: Locking feature for valves indicated in "Aboveground Manual Gas Shutoff Valve Schedule" Article.
  - 5. Listing by CSA or agency acceptable to authorities having jurisdiction for valves 1 inch and smaller.
  - 6. Valves 1-1/4 inch and larger shall be suitable for LPG service, with "WOG" indicated on valve body.
- C. General Requirements for Metallic Valves, NPS 2 and Smaller for Vapor Service: Comply with ASME B16.33.
  - 1. CWP Rating: 125 psig.
  - 2. Threaded Ends: Comply with ASME B1.20.1.
  - 3. Dry seal Threads on Flare Ends: Comply with ASME B1.20.3.
  - 4. Tamperproof Feature: Locking feature for valves indicated in "Aboveground Manual Gas Shutoff Valve Schedule" Article.

5. Listing: Listed and labeled by an NRTL acceptable to authorities having jurisdiction for valves 1 inch and smaller.
  6. Service Mark: Valves 1-1/4 inch to NPS 2 shall have initials "WOG" permanently marked on valve body.
- D. One-Piece, Bronze Ball Valve with Bronze Trim: MSS SP-110.
1. Manufacturers: Legend, Nibco, or approved equal.
  2. Body: Bronze, complying with ASTM B 584.
  3. Ball: Chrome-plated brass.
  4. Stem: Bronze; blowout proof.
  5. Seats: Reinforced TFE; blowout proof.
  6. Packing: Separate packnut with adjustable-stem packing threaded ends.
  7. Ends: Threaded, flared, or socket as indicated in "Aboveground Manual Gas Shutoff Valve Schedule" Article.
  8. CWP Rating: 400 psig.
  9. Listing: Valves NPS 1 and smaller shall be listed and labeled by an NRTL acceptable to authorities having jurisdiction.
  10. Service: Suitable for LPG service with "WOG" indicated on valve body.
- E. Two-Piece, Full-Port, Bronze Ball Valves with Bronze Trim: MSS SP-110.
1. Manufacturers; NIBCO, Conbraco, Apollo, or approved equal.
  2. Body: Bronze, complying with ASTM B 584.
  3. Ball: Chrome-plated bronze.
  4. Stem: Bronze; blowout proof.
  5. Seats: Reinforced TFE; blowout proof.
  6. Packing: Threaded-body packnut design with adjustable-stem packing.
  7. Ends: Threaded, flared, or socket as indicated in "Aboveground Manual Gas Shutoff Valve Schedule" Article.
  8. CWP Rating: 600 psig.
  9. Listing: Valves NPS 1 and smaller shall be listed and labeled by an NRTL acceptable to authorities having jurisdiction.
  10. Service: Suitable for LPG service with "WOG" indicated on valve body.
- F. Two-Piece, Regular-Port Bronze Ball Valves with Bronze Trim: MSS SP-110.
1. Manufacturers; NIBCO, Apollo, or approved equal.
  2. Body: Bronze, complying with ASTM B 584.
  3. Ball: Chrome-plated bronze.

4. Stem: Bronze; blowout proof.
  5. Seats: Reinforced TFE.
  6. Packing: Threaded-body packnut design with adjustable-stem packing.
  7. Ends: Threaded, flared, or socket as indicated in "Aboveground Manual Gas Shutoff Valve Schedule" Article.
  8. CWP Rating: 600 psig.
  9. Listing: Valves NPS 1 and smaller shall be listed and labeled by an NRTL acceptable to authorities having jurisdiction.
  10. Service: Suitable for LPG service with "WOG" indicated on valve body.
- G. Bronze Plug Valves: MSS SP-78.
1. Manufacturers: Davis Valve, or approved equal.
  2. Body: Bronze, complying with ASTM B 584.
  3. Plug: Bronze.
  4. Ends: Threaded or socket as indicated "Aboveground Manual Gas Shutoff Valve Schedule" Article.
  5. Operator: Square head or lug type with tamperproof feature where indicated.
  6. Pressure Class: 125 psig.
  7. Listing: Valves NPS 1 and smaller shall be listed and labeled by an NRTL acceptable to authorities having jurisdiction.
  8. Service: Suitable for LPG service with "WOG" indicated on valve body.
- H. Valve Boxes:
1. Cast-iron, two-section box.
  2. Top section with cover with "GAS" lettering.
  3. Bottom section with base to fit over valve and barrel a minimum of 5 inches in diameter.
  4. Adjustable cast-iron extensions of length required for depth of bury.
  5. Include tee-handle, steel operating wrench with socket end fitting valve nut or flat head and with stem of length required to operate valve.

## **2.05 EARTHQUAKE VALVES**

- A. Earthquake Valves, Maximum Operating Pressure of 7 psig: Comply with ASCE 25.
1. Manufacturer: KOSO – The California Valve, or approved equal.
  2. Listing: Listed and labeled by an NRTL acceptable to authorities having jurisdiction.
  3. Maximum Operating Pressure: 7 psig.
  4. Cast-aluminum body with nickel-plated chrome steel internal parts.
  5. Nitrile-rubber valve washer.

6. Sight windows for visual indication of valve position.
  7. Threaded-end connections complying with ASME B1.20.1.
- B. Earthquake Valves, Maximum Operating Pressure of 60 psig: Comply with ASCE 25.
1. Manufacturer: KOSO – The California Valve, or approved equal.
  2. Listing: Listed and labeled by an NRTL acceptable to authorities having jurisdiction.
  3. Maximum Operating Pressure: 60 psig.
  4. Cast-aluminum body with stainless-steel internal parts.
  5. Nitrile-rubber, reset-stem o-ring seal.
  6. Valve position, open or closed, indicator.
  7. Composition valve seat with clapper held by spring or magnet locking mechanism.
  8. Level indicator.
  9. End Connections: Threaded for valves NPS 2 and smaller.

## **2.06 PRESSURE REGULATORS**

- A. General Requirements:
1. Single stage and suitable for LPG.
  2. Steel jacket and corrosion-resistant components.
  3. Elevation compensator.
  4. End Connections: Threaded for regulators NPS 2 and smaller.
- B. Line Pressure Regulators: Comply with ANSI Z21.80.
1. Manufacturer: Fisher, or approved equal
  2. Body and Diaphragm Case: Cast iron or die-cast aluminum.
  3. Springs: Zinc-plated steel; interchangeable.
  4. Diaphragm Plate: Zinc-plated steel.
  5. Seat Disc: Nitrile rubber resistant to gas impurities, abrasion, and deformation at the valve port.
  6. Orifice: Aluminum; interchangeable.
  7. Seal Plug: Ultraviolet-stabilized, mineral-filled nylon.
  8. Single-port, self-contained regulator with orifice no larger than required at maximum pressure inlet and no pressure sensing piping external to the regulator.
  9. Pressure regulator shall maintain discharge pressure setting downstream and not exceed 150 percent of design discharge pressure at shutoff.
  10. Overpressure Protection Device: Factory mounted on pressure regulator.
  11. Atmospheric Vent: Factory- or field-installed, stainless-steel screen in opening if not connected to vent piping.



12. Maximum Inlet Pressure: 5 psig
- C. Appliance Pressure Regulators: Comply with ANSI Z21.18.
1. Manufacturer: Fisher, or approved equal
  2. Body and Diaphragm Case: Die-cast aluminum.
  3. Springs: Zinc-plated steel; interchangeable.
  4. Diaphragm Plate: Zinc-plated steel.
  5. Seat Disc: Nitrile rubber.
  6. Seal Plug: Ultraviolet-stabilized, mineral-filled nylon.
  7. Factory-Applied Finish: Minimum three-layer polyester and polyurethane paint finish.
  8. Regulator may include vent limiting device, instead of vent connection, if approved by authorities having jurisdiction.
  9. Maximum Inlet Pressure: 5 psig

#### **2.07 DIELECTRIC FITTINGS**

- A. General Requirements: Assembly of copper alloy and ferrous materials with separating nonconductive insulating material. Include end connections compatible with pipes to be joined.
- B. Dielectric Unions:
1. Manufacturer: Legend, Watts, or approved equal.
  2. Standard: ASSE 1079.
  3. Pressure Rating: 125 psig minimum at 180 deg.
  4. End Connections: Solder-joint copper alloy and threaded ferrous.

#### **2.08 TRANSPORT TRUCK UNLOADING FACILITY**

- A. Description: Comply with requirements in NFPA 58.
1. Support structure consisting of a minimum 6-inch steel channel or 6-by-4-inch rectangular steel tubing, a minimum of 36 inches above and below grade.
  2. Liquid-fill and vapor-return, quick-disconnect fittings.
  3. Liquid and vapor shutoff valves with hydrostatic relief valves mounted between the quick-disconnect fittings and shutoff valves.
  4. Excess-flow safety shutoff valve in vapor-return line.
  5. Backflow check valve in liquid-fill line.
  6. Emergency shutoff valves.
  7. Nitrogen piping from pneumatic N2 cylinders to the emergency shut off valves at truck unloading facility.

**2.09 VAPORIZERS (DIRECT TYPE – DIRECT FIRED LP GAS VAPORIZERS)**

- A. Description: Factory-fabricated, -assembled, and -tested vaporizer with heat exchanger sealed pressure-tight, built on a steel base; including insulated jacket, flue-gas vent, liquid fuel supply and vapor connections, and controls. Assembly shall be FMG labeled and comply with NFPA 58 and NFPA 70.
  - 1. Manufacturer: RANSOME Manufacturing, or approved equal.
- B. Fabricate base and attachment to vaporizers with reinforcement strong enough to resist vaporizer movement during a seismic event when steel base is anchored to a concrete base.
- C. Casing:
  - 1. Mineral-fiber insulation, a minimum of 2 inches thick, surrounding the heat exchanger.
  - 2. Integral one-piece skid with forklift access holes.
  - 3. Lifting lugs on top of vaporizer.
  - 4. Flue rain cap and bird screen.
  - 5. Sheet metal jacket with screw-fastened closures and powder-coat protective finish.
  - 6. Mounting base to secure boiler to concrete base.
  - 7. Control Compartment Enclosure: NEMA 250, Type 4, enclosure housing control panels for LPG-fired vaporizers. Explosion-proof control compartment construction required for electric vaporizers. 120V Power required for ignition valve operation.
- D. LPG Liquid and Vapor Circuit Specialties:
  - 1. Y-type strainer with drain valve at inlet.
  - 2. Vaporizer coil safety pressure relief valve.
  - 3. Vaporizer coil blowdown valve.
  - 4. Vapor outlet isolation valve.
  - 5. Pressure gages, a minimum of 2-1/2 inches in diameter, at liquid inlet and vapor discharge. Gages shall have operating-temperature ranges so normal operating range is at approximately 50 percent of full range.
  - 6. Inlet safety solenoid valve to close with off-normal operation alarm.
  - 7. Backflow check valve in bypass around inlet safety solenoid valve.
  - 8. Liquid carryover or float-type safety shutoff switch.
  - 9. LPG Vapor Filter: Steel shell designed and manufactured per ASME Boiler and Pressure Vessel Code, Section VIII, Division 1; factory mounted on vaporizer discharge. Shells larger than 5 inches shall be ASME "U" stamped. Fill with stainless-steel, woven-mesh coalescing element to remove 99 percent of particles larger than 10 microns. 250-psig minimum working pressure. Finish with corrosion-resistant coating for an exterior application. Include factory-mounted and -piped, differential pressure gage with gage cocks in and out, and minimum NPS 3/4 full-port, ball-type drain valve.

- E. Capacities and Characteristics:
  - 1. Heating Fuel: Propane.
  - 2. Vaporization Heat Exchanger:
    - a. Minimum Working-Pressure Rating: 250 psig.
    - b. Test Pressure: 375 psig
  - 3. LPG Vaporization Rate: 240 gph.
  - 4. Entering-LPG Temperature: Ambient
  - 5. Leaving-LPG Temperature: 110 deg F.
  - 6. Discharge-LPG Pressure: 5 psig
  - 7. Burner Gas Input: 36.3 MBtuh

## **2.10 LABELING AND IDENTIFYING**

- A. Detectable Warning Tape: Acid- and alkali-resistant PE film warning tape manufactured for marking and identifying underground utilities, a minimum of 6 inches wide and 4 mils thick, continuously inscribed with a description of utility, with metallic core encased in a protective jacket for corrosion protection, detectable by metal detector when tape is buried up to 30 inches deep; colored yellow.

## **PART 3 – EXECUTION**

### **3.01 EXAMINATION**

- A. Examine roughing-in for LPG piping system to verify actual locations of piping connections before equipment installation.
- B. Proceed with installation only after unsatisfactory conditions have been corrected.

### **3.02 EARTHWORK**

- A. Comply with requirements shown on Contract Drawings.

### **3.03 PREPARATION**

- A. Close equipment shutoff valves before shutting off LPG supply to premises or piping section(s).
- B. Inspect LPG piping according to NFPA 58 and NFPA 54 (National Fuel Gas Code) to determine that LPG utilization devices are turned off in piping section affected.
- C. Comply with NFPA 58 and NFPA 54 (National Fuel Gas Code) requirements for prevention of accidental ignition.

### **3.04 OUTDOOR PIPING INSTALLATION**

- A. Comply with NFPA 58 and NFPA 54 requirements for installation and purging of LPG piping.
- B. Install underground, LPG piping buried at least 36 inches below finished grade.
  - 1. If LPG piping is installed less than 36 inches below finished grade, install it in containment conduit.

- C. Install underground, PE, LPG piping according to ASTM D 2774.
- D. Install underground piping and conduits with detectable warning tape per section 3.11 – Labeling and Identifying.
- E. Steel Piping with Protective Coating:
  - 1. Apply joint cover kits to pipe after joining to cover, seal, and protect joints.
  - 2. Repair damage to PE coating on pipe as recommended in writing by protective coating manufacturer.
  - 3. Replace pipe having damaged PE coating with new pipe.
- F. Copper Tubing with Protective Coating:
  - 1. Apply joint cover kits over tubing to cover, seal, and protect joints.
  - 2. Repair damage to PE coating on pipe as recommended in writing by protective coating manufacturer.
- G. Install fittings for changes in direction and branch connections.
- H. Install pressure gage upstream and downstream from each service regulator.

### **3.05 VALVE INSTALLATION**

- A. Install manual gas shutoff valve for each gas appliance ahead of corrugated stainless-steel tubing, or copper connector.
- B. Install underground valves with valve boxes.
- C. Install regulators and overpressure protection devices with maintenance access space adequate for servicing and testing.
- D. Install earthquake valves aboveground outside buildings according to listing.
- E. Install anode for metallic valves in underground PE piping.

### **3.06 PIPING JOINT CONSTRUCTION**

- A. Ream ends of pipes and tubes and remove burrs.
- B. Remove scale, slag, dirt, and debris from inside and outside of pipe and fittings before assembly.
- C. Threaded Joints:
  - 1. Thread pipe with tapered pipe threads complying with ASME B1.20.1.
  - 2. Cut threads full and clean using sharp dies.
  - 3. Ream threaded pipe ends to remove burrs and restore full ID of pipe.
  - 4. Apply appropriate tape or thread compound to external pipe threads unless dry seal threading is specified.
  - 5. Damaged Threads: Do not use pipe or pipe fittings with threads that are corroded or damaged. Do not use pipe sections that have cracked or open welds.

D. Welded Joints:

1. Construct joints according to AWS D10.12/D10.12M, using qualified processes and welding operators.
2. Bevel plain ends of steel pipe.
3. Patch factory-applied protective coating as recommended by manufacturer at field welds and where damage to coating occurs during construction.

E. Brazed Joints: Construct joints according to AWS's "Brazing Handbook," Ch. 22, "Pipe and Tube."

F. Flared Joints: Cut tubing with roll cutting tool. Flare tube end with tool to result in flare dimensions complying with SAE J513. Tighten finger tight, then use wrench. Do not overtighten.

G. PE Piping Heat-Fusion Joints: Clean and dry joining surfaces by wiping with clean cloth or paper towels. Join according to ASTM D 2657.

1. Plain-End Pipe and Fittings: Use butt fusion.
2. Plain-End Pipe and Socket Fittings: Use socket fusion.

### **3.07 HANGER AND SUPPORT INSTALLATION**

A. Install hangers for steel piping, with maximum spacing and minimum rod diameters, to comply with MSS-58, locally enforced codes, and authorities having jurisdiction requirements, whichever are most stringent.

B. Install hangers for corrugated stainless-steel tubing, with maximum horizontal spacing and minimum rod diameters, to comply with manufacturer's written instructions, locally enforced codes, and authorities having jurisdiction requirements, whichever are most stringent.

C. Support horizontal piping within 18 inches of each fitting.

D. Support vertical runs of steel piping to comply with MSS-58, locally enforced codes, and authorities having jurisdiction requirements, whichever are most stringent.

E. Support vertical runs of corrugate stainless-steel tubing to comply with manufacturer's written instructions, locally enforced codes, and authorities having jurisdiction requirements, whichever are most stringent.

### **3.08 CONNECTIONS**

A. Install LPG piping electrically continuous and bonded to gas appliance equipment grounding conductor of the circuit powering the appliance according to NFPA 70.

B. Install piping adjacent to appliances to allow service and maintenance of appliances.

C. Connect piping to appliances using manual gas shutoff valves and unions. Install valve within 72 inches of each gas-fired appliances and equipment. Install union between valve and appliances or equipment.

D. Sediment Traps: Install tee fitting with capped nipple in bottom to form drip, as close as practical to inlet of each appliance.

### **3.09 TRANSPORT TRUCK UNLOADING FACILITY**

- A. Install transport truck unloading in a cast-in-place concrete base, 48 inches square by 36 inches deep. Set top of concrete base at least 6 inches above finished grade.
- B. Fill Station shall include all components needed for fuel fill activation, fuel fill stop, and fuel fill emergency shutoff.
- C. Provide emergency shutoff systems that function according to the following description:
  - 1. Remote emergency shutoff station: a remote emergency shut off station that upon activation will electrically close a normally open N2 solenoid valve de-energizing pneumatically operated, normally open, internal tank liquid supply and vapor discharge valves, shutting off the flow of liquid and gaseous propane from the tank to the distribution system.
  - 2. During filling operations:
    - a. At the tank: internal liquid fill and vapor out isolation valves that are normally closed until pneumatically charged with N2 pressure by the filling truck driver operating a transfer charge valve. The valves will automatically close in the case of fire (melt away tubing), upon activation of the E-Stop button on the transfer skid at the fill station, or closure of the transfer charge valve.
    - b. At the fill station: independent emergency shut off valves located in the liquid fill and vapor return lines. Similar to the valves at the tank, these valves at the fill station are normally closed until pneumatically charged with N2 pressure by the filling truck driver operating a transfer charge valve. The valves will automatically close in the case of fire (melt away tubing), upon activation of the E-Stop button on the transfer skid at the fill station, or closure of the transfer charge valve. Additionally, these valves can be manually closed by pulling a remotely mounted mechanical cable release.
    - c. Provide further protection at the fill station by integral check valves and pull away valves in the truck transfer hoses, to guard against product loss from improper movement of the filling truck.
- A. Install remote emergency shutoff station for propane liquid and vapor supply lines at corner of Building G in an accessible and easily recognizable area. Install minimum 25' long emergency pull cable from the two fill station emergency shut off valves (identified on P&ID drawing as PTR-ES1 & PTR-ES2) along the LPG fill and vapor return pipe supports. Terminate the pull handle at one of the pipe support stanchions.
- B. Install at least two 6-inch-diameter metal bollards set in and filled with concrete on both sides of transport truck unloading. Bollard length shall be at least 48 inches above grade, with 18" diameter concrete encasement.

### **3.10 VAPORIZER INSTALLATION**

- A. Install vaporizer with access space for periodic maintenance.
- B. Set vaporizers on and anchor to concrete base.
- C. Connect liquid line from pump set, and vapor supply to distribution piping.

- D. Install backup connection from vapor space of container to inlet of pressure-regulating valve at vaporizer discharge to bypass the vaporizer during maintenance. Install shutoff valves to change source from vaporizer to storage container.
- E. Connect 120V power supply for vaporizer ignition valve.

### **3.11 LABELING AND IDENTIFYING**

- A. Nameplates, pipe identifications, and signs shall be provided per ASME A13.1 and NFPA 58.
- B. Install detectable warning tape directly above gas piping, 12 inches below finished grade, except 6 inches below subgrade under pavements and slabs.
- C. In joint trenches, do not omit detectible warning tape for underground gas piping. Coordinate installation location of detectable warning tape with required warning tapes for electrical and communication conduits.

### **3.12 PAINTING**

- A. Paint all exposed surfaces in accordance with Technical Specifications **Section 09 91 23 – Painting**.
- B. Damage and Touchup: Repair marred and damaged factory-applied finishes with materials and by procedures to match original factory finish.
- C. Paint propane (liquified and gaseous) piping yellow.

### **3.13 FIELD QUALITY CONTROL**

- A. Test, inspect, and purge LPG according to NFPA 58 and NFPA 54 and requirements of authorities having jurisdiction.
- B. LPG piping will be considered defective if it does not pass the following tests and inspections:
  - 1. UPC Certification
  - 2. CSA B137.4 Certification
  - 3. Compliance with the LPG Piping Fusion Procedure
  - 4. ASTM F2897 Bar Code – for source tracking and identification
  - 5. Pressure test to 125% of the MOP (Max Operating Pressure).
- C. Prepare test and inspection reports.

### **3.14 DEMONSTRATION**

- A. Engage a factory-authorized vaporizer service representative to train VTA maintenance personnel to adjust, operate, and maintain LPG equipment.

### **3.15 OUTDOOR PIPING SCHEDULE**

- A. Aboveground LPG liquid piping shall be the following:
  - 1. Schedule 80 steel pipe, malleable-iron threaded fittings and threaded joints. Coat pipe and fittings with protective coating for steel piping.
  - 2. Annealed-temper copper tube, Type L, with wrought-copper fittings and brazed joints. Coat pipe and fittings with protective coating for copper tubing.

- B. Underground LPG vapor piping shall be the following:
  - 1. MDPE DRISCOPEX 6500 pipe, or approved equal, and HDPE fittings specified above joined by electro-fusion; service-line risers with tracer wire terminated in an accessible location.
- C. Aboveground LPG vapor piping shall be one of the following:
  - 1. Schedule 40, steel pipe with malleable-iron fittings and threaded joints.
  - 2. Schedule 40, steel pipe with wrought-steel fittings and welded joints.
  - 3. Annealed-temper copper tube, Type L, with wrought-copper fittings and brazed joints. Coat pipe and fittings with protective coating for copper tubing.
- D. Branch Piping in Cast-in-Place Concrete to Single Appliance: Annealed-temper copper, with wrought-copper fittings and brazed joints. Install piping embedded in concrete with no joints in concrete.
- E. Containment Conduit: Schedule 40, steel pipe with wrought-steel fittings and welded joints. Coat pipe and fittings with protective coating for steel piping.

**3.16 ABOVEGROUND MANUAL GAS SHUTOFF VALVE SCHEDULE**

- A. Aboveground Liquid Piping:
  - 1. Two-piece, full-port, bronze ball valves with bronze trim.
- B. Valves for pipe NPS 2 and smaller at service meter shall be one of the following:
  - a. One-piece, bronze ball valve with bronze trim.
  - b. Two-piece, full-port, bronze ball valves with bronze trim.
  - c. Bronze plug valve.
- C. Distribution piping valves for pipe NPS 2 and smaller shall be one of the following:
  - 1. One-piece, bronze ball valve with bronze trim.
  - 2. Two-piece, regular-port, bronze ball valves with bronze trim.
  - 3. Bronze plug valve.

**END OF SECTION 23 11 26**



## **SECTION 23 13 23 – FACILITY ABOVEGROUND LPG FUEL STORAGE TANKS**

### **PART 1 – GENERAL**

#### **1.01 SUMMARY**

- A. Section Includes
  - 1. Horizontal, steel, Liquefied-Propane Gas (LPG) storage tank and appurtenances.
  - 2. Tank nozzles, tank accessories, and tank connected components.
  - 3. LPG Fill station, fill station accessories, and fill station connected components.
  - 4. Tank monitoring telemetry system.

#### **1.02 RELATED SECTIONS**

- A. Technical Specifications Section 23 11 26 – Facility Liquefied-Petroleum Gas Piping

#### **1.03 REFERENCES**

- A. American Society of Civil Engineers:
  - 1. ASCE 7-2016 – Minimum Design Loads for Building & Other Structures
- B. American Society of Mechanical Engineers:
  - 1. ASME Boiler & Pressure Vessel Code - Section VIII – Division 1
  - 2. ASME A13.1 – Scheme for the Identification of Piping Systems
- C. American Welding Society:
  - 1. AWS D1.1 / D1.1M – Structural Welding Code – Steel
- D. Steel Structures Painting Council (SSPC) / National Association of Corrosion Engineers (NACE):
  - 2. SSPC-SP6 / NACE No. 3 – Commercial Blast Cleaning
- E. Steel Tank Institute:
  - 3. STI R912 – Installation Instructions for Shop Fabricated Aboveground Storage Tanks for Flammable, Combustible Liquids.
- F. Codes
  - 1. California Code of Regulations, Title 8 – Industrial Relations
  - 2. California Code of Regulations, Title 8, Chapter 4, Subchapter 1 – Unfired Pressure Vessel Safety Orders
  - 3. National Fire Protection Association - NFPA 10 – Standard for Portable Fire Extinguishers
  - 4. National Fire Protection Association - NFPA 54 – National Fuel Gas Code
  - 5. National Fire Protection Association – NFPA 58 – Liquefied Petroleum Gas Code

6. National Fire Protection Association – NFPA 70 – National Electrical Code (NEC) – Chapter 5 – Article 500 – Hazardous Locations Classifications

#### **1.04 SUBMITTALS**

- A. Submittal procedures must be in accordance with the applicable provisions of:
  - 1. Section 6.6 Contract Data Requirements**
  - 2. Section 7.41 Product Options, Supplier Approval and Substitutions**
  - 3. Section 7.43 Submittal of Shop Drawings, Product Data and Samples**
  - 4. Section 7.49.1 Certificate of Compliance**
  - 5. Appendix B Contract Data Requirements**
- B. Product Data:
  1. Tank: volume, orientation, operating pressure, Maximum Allowable Working Pressure (MAWP), and temperature ratings.
  2. Tank nozzles and connected components.
  3. Tank and fill station related valves, gauges, fill level indication equipment.
  4. Tank accessories.
  5. Fill station and accessories / connected components.
  6. Telemetry monitoring system and accessories.
- C. Shop Drawings:
  1. Shop Drawing Scale: 1/4 inch per foot.
  2. Indicate dimensions, components, and location and size of each field connection.
  3. Include plans, elevations, sections, and ballast pads and anchors, and lifting or supporting points.
  4. Submit shop drawings for:
    - a. Tank, tank nozzles, and connected components.
    - b. Tank support structures and anchorages.
    - c. Fill station fill station accessories, and connected components.
- D. Seismic Qualification Certificates: For Aboveground Storage Tanks (ASTs), accessories, and components, from manufacturer.
  1. Basis for Certification: Indicate whether withstand certification is based on actual test of assembled components or on calculation.
  2. Dimensioned outline drawings of equipment unit: Identify center of gravity and locate and describe mounting and anchorage provisions.
  3. Detailed description of equipment anchorage devices on which the certification is based and their installation requirements.

- E. Brazing certificates.
- F. Welding certificates.
- G. Source quality-control test and inspection reports: Indicate and interpret test results for compliance with performance requirements before shipping.
- H. Field quality-control test and inspection reports: Indicate and interpret test results for compliance with performance requirements.
- I. Example / sample warranty.
- J. Telemetry monitoring system installation drawings and instructions.
- K. Telemetry programming equipment.
- L. Closeout Submittals:
  - 1. Operation and maintenance data: for LPG equipment and accessories.
    - a. Emergency operations manual with procedures for addressing emergency hazard conditions with tank or LPG system.
    - b. Regular operations manual with procedures for normal operations of LPG system, including tank refiling operations.
    - c. Settings and calibration information.
    - d. Maintenance manual, with information on routine and preventative maintenance procedures and recommendations.
    - e. Staff training sessions on emergency operations, regular operations, and LPG system maintenance, with training materials.
  - 2. Tank manufacturer's certification letter.
  - 3. Warranty certificates.

#### **1.05 QUALITY ASSURANCE**

- A. Code Compliance: Comply with EPA, state, and local Authorities Having Jurisdiction (AHJ), Technical Specifications, Contract Drawings, and requirements of all applicable codes, including but not limited to California Code of Regulations Title 8, and NFPA 58.
- B. Steel Support Welding Qualifications: Qualify procedures and personnel according to AWS D1.1/D1.1M, "Structural Welding Code - Steel."

#### **1.06 WARRANTY**

- A. Warranty: Manufacturer agrees to repair or replace components of LPG storage tanks that fail in materials or workmanship within specified warranty period.
  - 1. Storage Tanks:
    - 1) Failures include, but are not limited to, the following when used for storage of fuel at temperatures not exceeding 125 deg F:
      - i. Structural failures including cracking, breakup, and collapse.

- ii. Corrosion failure including external and internal corrosion of steel tanks.
- 2) Warranty Period: 1 year
- 3) Contractor must provide certification from tank manufacturer that the tank installation has been inspected by an authorized representative of the manufacturer, and that the tank installation and connection of all related LPG system components has been performed in a manner that the tank manufacturer will honor the warranty in full, for this specific tank installation.

## **PART 2 – PRODUCTS**

### **2.01 HORIZONTAL, STEEL, LIQUID PROPANE FUEL AST**

- A. Description: 2017 ASME Code for Pressure Vessels, Section VIII, Division 1 compliant, single-wall, horizontal, steel tank.
- B. Construction: Fabricated with welded, carbon steel; suitable for operation at maximum 250 psig static pressure and for storing liquid propane with specific gravity up to 0.504 and with maintained temperature up to 125 deg F.
  - 1. Grade: SA-612, SA-455, or SA-516-70, as selected by the manufacturer to meet the requirements for this specific application.
- C. Supports Base: Cast in place reinforced concrete footing
- D. Supports Tank: Manufacturer's welded steel saddles for field installation.
  - 1. Number of Supports: 2 ea.
- E. Capacities and Characteristics:
  - 1. Capacity: 30,000 gal.
  - 2. Diameter: 109.346" (OD)
  - 3. Length: 791 3/8"
  - 4. Connection Sizes:
    - a. Fill Line: 2" - 3000# half coupling
    - b. Vent Line: 2" - 3000# half coupling.
    - c. Liquid Outlet: 3" - 5-1/2"OD SPCL coupling.
    - d. Vapor Return: 2" - 3000# half coupling w/pipe
    - e. Pressure Relief: 2" – 3000# half coupling (3ea)
    - f. Gauge: 2" - 3000# half coupling
    - g. Float Gauge: 2-1/2" - 3000# half coupling
    - h. Thermowell: 3/4" – 6000# full coupling
  - 5. Manholes:
    - a. Number Required: 1ea.

- b. Diameter: 16" 150# RF Pad Flange w/cover.
- 6. Liquid Propane Grade Number: Commercial Grade.
- F. Standards of Manufacturers: References to manufacturer's name and model number are used to establish a quality standard for this Project. It is understood that such references are used to facilitate the description of the product, and are deemed to be followed by the words "or approved equal".
  - 1. Arcosa Tank, LLC. 30,000 nominal United States Water Gallons (U.S.W.G.) , 109.346" O.D. horizontal storage tank (250 psi), as specified on the Contract Drawings shall establish the performance and quality standard for this Project. Tank and support saddles must be furnished as a complete package from the tank manufacturer. Refer to the Contract Drawings for complete requirements.
    - a. Tank foundation slab and anchorages shown on the Contract Drawings are based on the Arcosa Tank, LLC. 30,000 nominal United States Water Gallons (U.S.W.G.), 109.346" O.D. horizontal storage tank (250 psi).
    - b. Any suggested tank substitution from an acceptable manufacturer must fit within the current design of Work, meaning no changes to the current design will be necessary in order to accommodate the substitution.
  - 2. Acceptable manufacturers:
    - a. Arcosa Tank, LLC
    - b. Or approved equal.

## **2.02 SHOP PAINTING OF AST**

- A. Apply manufacturer's standard prime coat to exterior steel surface of AST and steel support.
- B. Prepare exterior steel surface of AST and tank supports.
- C. Shop Cleaning: After fabrication, blast clean according to SSPC-SP 6/NACE No. 3.
- D. After cleaning, remove dust or residue from cleaned surfaces.
- E. If surface develops rust before prime coat is applied, repeat surface preparation.
- F. Apply manufacturer's standard prime coat to shop-cleaned, dry surface same day as surface preparation.
- G. Apply manufacturer's standard two-component, epoxy finish coats.

## **2.03 LIQUID PROPANE AST ACCESSORIES**

- A. Tank Manholes: See under paragraph 2.3 – E – 5. above
- B. Pipe (nozzle) connection fittings: See under paragraph 2.3 – E – 4. above
- C. Striker Plates: Inside tank, on bottom below fill, vent, sounding, gage, and other tube openings.
- D. Lifting Lugs: For handling and installation.

- E. Ladders: Fiberglass or extruded aluminum ladder near pressure relief valve bank to reach tank top for valve maintenance/repair.
- F. Equip the tank with accessories indicated in the propane ("P") drawings of the Contract Drawings.

#### **2.04 LIQUID-LEVEL GAGE SYSTEM**

- A. All internal liquid-level fixtures can be provided and specified by tank manufacturer or installer. As indicated on the plans, there will be a dip-tube type gauge on one side of the tank and a float gauge style gauge on the other side of the tank. The float gauge will have a remote ready dial so that in the future ALC controls can be added to monitor the tank level through the ALC system .

#### **2.05 TELEMETRY MONITORING SYSTEM**

- A. Independent Tank Level Monitoring system to autonomously monitor and report tank conditions. At a minimum, tank fill level must be monitored.
- B. System must be externally mounted and not rely on direct connection to any internal tank equipment, or existing tank gauges.
- C. System must be rated for "Class 1, Division 2, Group D" or "Class 1, Zone 2, Group IIA" installation locations.
- D. Measurements: A remote ultrasonic gauge reading system with Satellite based transmitter to provide readings with an accuracy of +/- 2% or better. Readings to be corrected for ambient temperature.
- E. Power: System must be self-powered and not rely on any end user provided source of power.
  - 1. Battery life must exceed two years.
- F. Reporting System: System shall be wireless (satellite based) and not require an end user provided local communication connection (wired internet, Wi-Fi, POTS phone lines, etc.).
- G. Monitoring Intervals: System shall be set to take one measurement daily, but capable of at least two measurements per day at VTA's discretion for measurement intervals.
- H. Notifications: System shall be capable of providing automated email and/or SMS/MMS cellular phone notifications for fill level and alert conditions. System shall be capable of notifications to at least five different contacts.
- I. Status & History: System shall have a web-based portal for end users to logon and view current tank status (most recent measurement), and review measurement history for at least one year's worth of data collected.
- J. Setup and configuration: Contractor shall install and configure system to be fully operational, including all necessary programming, testing, and coordination with monitoring service. The specified system requires an Android OS based device to effect programming of the unit. Contractor shall furnish to VTA one (1) mobile Android based tablet (factory equipped with the latest revision of Android OS available at the time of bid) for setup and effecting any future configuration changes to the monitoring system. Contractor to setup monitoring account on VTA's behalf, in VTA's name, and coordinate with VTA for necessary credentials and

information required for account setup and notification programming. Contractor to pay for all system monitoring costs until Final Acceptance of the contract by VTA.

- K. Tank Monitoring System shall be Xact Large Tank Monitoring System (model number XACT15096 with XACT31012) by Xact Tank Monitoring Systems, or approved equal.

## **2.06 SOURCE QUALITY CONTROL**

- A. Pressure test and inspect LPG storage tanks, after fabrication and before shipment, according to ASME and the following:
  - 1. Single-Wall Steel AST's: 2017 ASME Boiler & Pressure Vessel Code - Section VIII – Division 1 compliant.
- B. Affix standards organization's code stamp.
- C. The following documentation must be provided with the pressure vessel when shipped from the manufacturer:
  - 1. Written pressure test procedure.
  - 2. Pressure test results (applied pressure and duration).
  - 3. Tank exterior pre-cleaning procedure and list of materials used.
  - 4. Tank exterior painting procedure and list of materials used.
  - 5. Tank interior cleaning / passivation / coating procedures and list of materials used.
  - 6. Tank welding certificate with at least one longitudinal and one radial seam X-ray film from both ends of the tank.
  - 7. Final release with bill of material and spare parts list.

## **PART 3 – EXECUTION**

### **3.01 EARTHWORK**

- A. Comply with requirements detailed on civil and structural engineering drawings for excavating, trenching, and backfilling, in preparation for cast-in-place concrete base to be constructed by Contractor.

### **3.02 LIQUIFIED PROPANE STORAGE TANK INSTALLATION**

- A. Install tank bases and supports.
- B. Concrete Bases: Anchor AST to concrete base according to equipment manufacturer's written instructions and according to seismic codes at project.
  - 1. Construct concrete bases of dimensions indicated, but not less than 12" larger in both directions than supported unit.
  - 2. Install anchor bolts for supported equipment per structural drawings.
  - 3. Place and secure anchorage devices. Use supported equipment manufacturer's setting drawings, templates, diagrams, instructions, and directions furnished with items to be embedded.

4. Install anchor bolts to elevations required for proper attachment to supported equipment.
5. Use 28-day, compressive-strength concrete and reinforcement as specified in Structural Design (“footings” mix design per structural drawings).
- C. Ladder Access Pad: Provide 4” thick concrete pad (“slabs on grade” mix design per structural drawings) to facilitate stable ladder access near pressure relief valve bank. Horizontal dimension of pad shall be as determined necessary to facilitate safe usage of ladder provided per section 2.5.E above.
- D. Nitrogen Tank Access Walkway: Provide 4” thick, 36” wide concrete walkway (“slabs on grade” mix design per structural drawings) to facilitate exchange of compressed nitrogen (N2) cylinders, from adjacent drive aisle to N2 storage location.
- E. Connect piping and fittings.
- F. Install ground connections.
- G. Install tank level and monitoring devices.
- H. Install steel ASTs according to STI R912.
- I. After installation, pressure testing, and acceptance procedure is completed, first tank filling shall be conducted by an accredited LPG supplier in the presence of the tank manufacturer representative, VTA, and any applicable AHJ.
  1. Secure and provide all necessary equipment and personnel to conduct all required testing, and oversight, including securing manufacturer’s personnel or designated representative.
  2. Supply all fuel and consumables required for testing, demonstration, and startup purposes.
  3. Supply first full LPG tank fill after all testing and startup is complete.
  4. Provide a minimum of 14 days advance notice of scheduled initial fuel filling operation.
- J. Provide minimum of five (5) UL rated, fire extinguishers in outdoor rated weather proof enclosures. Comply with NFPA 10 and NFPA 58. Each shall have a minimum capacity of 18 lb. of dry chemical, with a B:C rating, and discharge rate of 1 lb./sec or greater. Coordinate with VTA for exact mounting or freestanding locations.
- K. Provide all required equipment and perform all related work to provide a fully functional propane storage system, consistent with the contract requirements, applicable codes, and the requirements of the AHJ’s.

### **3.03 LABELING AND IDENTIFYING**

- A. Nameplates, pipe identification, and signs shall be provided per ASME A13.1 and NFPA 58.

### **3.04 FIELD PAINTING OF AST**

- A. Prepare and touch up damaged exterior surface of AST and supports.
- B. Prepare exterior steel surface of AST and tank supports.



- C. Field Cleaning: Blast clean according to SSPC-SP 6/NACE No. 3
- D. After cleaning, remove dust or residue from cleaned surfaces.
- E. If surface develops rust before prime coat is applied, repeat surface preparation.
- F. Apply manufacturer's standard prime coat to field-cleaned, dry surface same day as surface preparation.
- G. Apply manufacturer's standard two-component, epoxy finish coats in accordance with published repair recommendations and procedures.

### **3.05 FIELD QUALITY CONTROL**

- A. Perform the following tests and inspections with the assistance of a factory-authorized service representative:
  - 1. Pre-Functional Inspections:
    - a. Tank manufacturers shall provide pre-functional checklists for Contractor to visually inspect all system components prior to functional testing to be performed with tank manufacturer representative on site. Complete all pre-functional inspections and tests as required by tank manufacturer and all associated system equipment (fuel fill station, vaporizers, accessories) a minimum of ten days prior to factory-authorized services representative arriving on site. Submit test results to VTA within two business days of test or inspection completion.
    - b. Factory-authorized service representative shall review pre-functional inspections checklist and test reports prepared by Contractor and note any deficiencies. Factory-authorized service representative shall field verify all checklist items prior to commencing functional testing.
    - c. Pre-functional inspections checklists must be signed by Contractor and factory-authorized service representative. Contractor must resolve all discrepancies noted by the factory representative. Submit fully signed checklist for VTA review at least seven days prior to scheduled start of functional testing.
  - 2. Tank System Functional Test: Perform testing. VTA's LPG vendor will provide product and filling truck for the purposes of testing. Coordinate with VTA for scheduling of LPG refill service. Provide minimum of 14 days advance notice for scheduling.
    - a. Filling and Vapor space control from Filling Truck
    - b. Discharging to Vaporizers and Tank pressure control
    - c. Pneumatic N2 system operation
    - d. Tank safety valves and operation
- B. ASTs will be considered defective if they do not pass the pre-functional and functional tests and inspections.
- C. Provide VTA 30 days written notice in advance of functional tests to schedule AHJ's and any third-party test witnesses.

- D. Prepare and submit detailed test and inspection reports for all tests within two business days of completion of test or inspection.

**END OF SECTION 23 13 23**

**DIVISION 26 – ELECTRICAL**  
**SECTION 26 05 19 – LOW-VOLTAGE ELECTRICAL POWER CONDUCTORS AND CABLES**

**PART 1 – GENERAL**

**1.01 SUMMARY**

- A. Section Includes:
1. Building wires and cables rated 600 V and less.
  2. Connectors, splices, and terminations rated 600 V and less.

**1.02 RELATED SECTIONS**

- A. Technical Specifications Sections in Division 26 – Electrical

**1.03 SUBMITTALS**

- A. Submittal procedures must be in accordance with the applicable provisions of:
1. **Section 6.6 Contract Data Requirements**
  2. **Section 7.41 Product Options, Supplier Approval and Substitutions**
  3. **Section 7.43 Submittal of Shop Drawings, Product Data and Samples**
  4. **Section 7.49.1 Certificate of Compliance**
  5. **Appendix B Contract Data Requirements**
- B. Product Data: For each type of product. Include manufacturer's instructions.
- C. Shop Drawings: Modular wiring system, including layout of distribution devices, branch circuit conduit and cables, circuiting arrangement, and outlet devices.
- D. Field quality-control reports.

**PART 2 – PRODUCTS**

**2.01 CONDUCTORS AND CABLES**

- A. Subject to compliance with requirements, provide products by one of the following:
1. Alcan Products Corporation; Alcan Cable Division.
  2. Alpha Wire.
  3. Belden Inc.
  4. Encore Wire Corporation.
  5. General Cable Technologies Corporation.
  6. Southwire Incorporated.
  7. Or approved equal.

- B. All wire shall be 600 V, of a standard manufacturer, labeled by a nationally recognized testing laboratory (NRTL) recognized under 29 CFR 1910.7, and brought to the job in unbroken packages.
- C. All insulated conductors shall have 600-V insulation in accordance with NEMA WC70/ICEA S-95-658.
- D. Copper Conductors: Comply with NEMA WC 70/ICEA S-95-658.
- E. Conductor Insulation: Comply with NEMA WC 70/ICEA S-95-658.
- F. Thermoplastic-Insulated Building Wire:
  - 1. Typical: Type THWN-2 rated 90°C.
  - 2. Wet Locations and Underground Installations: Type THWN-2 rated 90°C for wet locations.
- G. Branch Circuits 6 AWG and Smaller: Copper conductor; 6 and 8 AWG, stranded conductor; 10 AWG and smaller, solid or stranded conductor.
- H. Control Circuits: Copper, stranded conductor.

## **2.02 CONNECTORS AND SPLICES**

- A. Manufacturers: Subject to compliance with requirements, provide products by one of the following:
  - 1. Gardner Bender.
  - 2. Hubbell Power Systems, Inc.
  - 3. Ideal Industries, Inc.
  - 4. IlSCO; a branch of Barden Corporation.
  - 5. NSi Industries LLC.
  - 6. O-Z/Gedney; a brand of the EGS Electrical Group.
  - 7. 3M; Electrical Markets Division.
  - 8. Tyco Electronics.
  - 9. Or approved equal.

## **2.03 SYSTEM DESCRIPTION**

- A. Electrical Components, Devices, and Accessories: Listed and labeled as defined in NFPA 70, by a qualified testing agency, and marked for intended location and application.
- B. Comply with NFPA 70.

## **PART 3 – EXECUTION**

### **3.01 CONDUCTOR MATERIAL APPLICATIONS**

- A. Use wire no smaller than 12 AWG for power and lighting circuits, and no smaller than 14 AWG for control wiring.

- B. Use 10 AWG conductors for 20-A, 120-V branch-circuit runs longer than 75 feet.

### **3.02 WIRE AND CABLE INSTALLATION SCHEDULE**

- A. Concealed Interior Locations: Building wire in raceways
- B. Exposed Interior Locations: Building wire in raceways Above Accessible Ceilings: Building wire in raceways, Wet or Damp Interior Locations: Building wire in raceway.
- C. Exterior Locations: Building wire in raceways.
- D. Underground Locations: Building wire in raceways.
- E. Complete raceway installation between conductor and cable termination points according to Section 260533 "Raceways and Boxes for Electrical Systems" prior to pulling conductors and cables.
- F. Install wire in raceway after interior of building has been physically protected from the weather and after all mechanical work which could damage conductors has been completed.
- G. Completely and thoroughly swab raceway system before installing conductors.
- H. Pull all conductors into a raceway at the same time.
- I. Use manufacturer-approved wire-pulling lubricant for pulling 4 AWG and larger wires. Use only talc or wire-pulling compounds listed by any NRTL as a lubricant for pulling conductors through raceways. If cleaning is required, use cleaning agents which will not damage conductor coverings.
- J. Do not exceed manufacturer's recommended maximum pulling tensions and sidewall pressure values.
- K. Use pulling means, including fish tape, cable, rope, and basket-weave wire/cable grips, that will not damage cables or raceway.
- L. Place an equal number of conductors for each phase of a circuit in same raceway or cable.
- M. Splice conductors only in outlet boxes, junction boxes, pull boxes, gutters, or panelboard gutters, as follows:
  - 1. 10 AWG or Smaller Conductors: Typically, use one of the following two methods:
    - a. Join together with pre-insulated spring-pressure connectors; Scotchlok types "Y," "R," and "B," Ideal "Wing Nut," or approved equal.
    - b. Join together with uninsulated, heavily-tinned splice cap of sufficient wall thickness that one indentation with proper tool will produce secure and intimate contact with wire. Cover with insulation to match existing wire.
- N. Neatly train and lace wiring inside boxes, equipment, and panelboards.
- O. Marking: In addition to color coding, number all signal and control wires at all termination points in cabinets, terminal boxes, equipment racks, control panels, and like areas, in accordance with schedules prepared by the equipment manufacturer, as shown on the Contract Drawings, or as shown on approved shop drawings. Use pre-marked, self-adhesive, wrap-around cloth-type markers; Brady "Perma-Code," Thomas & Betts "E-Z Code," or approved equal.
- P. Make equal conductor lengths for parallel circuits.

### 3.03 IDENTIFICATION

- A. Identify conductors and cables according to Section 260553 "Identification for Electrical Systems."
- B. Color Coding: Color code all conductors as follows:

THREE OR FOUR WIRE	"A" PHASE	"B" PHASE	"C" PHASE	NEUTRAL
208 Y/120 V	BLACK	RED	BLUE	WHITE

- C. Equipment Grounding: Any conductor intended solely for equipment grounding purposes shall be either bare or green in color. Conductors having white covering shall be used only for neutral grounding purposes and for neutral conductors. This requirement applies to all lighting, power, and control circuits.
- D. Identify each spare conductor at each end with identity number and location of other end of conductor, and identify as spare conductor.

### 3.04 SLEEVE AND SLEEVE-SEAL INSTALLATION FOR ELECTRICAL PENETRATIONS

- A. Install sleeves and sleeve seals at penetrations of exterior floor and wall assemblies. Comply with requirements in Section 260544 - Sleeves and Sleeve Seals for Electrical Raceways and Cabling.

### 3.05 FIRESTOPPING

- A. Apply approved firestopping to electrical penetrations of fire-rated floor and wall assemblies to restore original fire-resistance rating of assembly.

### 3.06 FIELD QUALITY CONTROL

- A. Perform the following tests and inspections with the assistance of a factory-authorized service representative if required:
  - 1. Inspect wire for physical damage and proper connection.
  - 2. Torque test conductor connections and terminations to manufacturer's recommended values.
  - 3. Perform continuity test on all power and equipment branch circuit conductors. Verify proper phasing connections.
  - 4. Perform visual and mechanical inspection and electrical tests as required.
- B. Test and Inspection Reports: Prepare a written report to record the following:
  - 1. Procedures used.
  - 2. Results that comply with requirements.

**END OF SECTION 26 05 19**

## **SECTION 26 05 26 – GROUNDING AND BONDING FOR ELECTRICAL SYSTEMS**

### **PART 1 – GENERAL**

#### **1.01 SUMMARY**

- A. Section Includes:
1. Grounding systems and equipment.
  2. Power system grounding.
  3. Electrical equipment and raceway grounding and bonding.

#### **1.02 RELATED SECTIONS**

- A. Technical Specifications Sections in Division 26 - Electrical

#### **1.03 SUBMITTALS**

- A. Submittal procedures must be in accordance with the applicable provisions of:
1. **Section 6.6 Contract Data Requirements**
  2. **Section 7.41 Product Options, Supplier Approval and Substitutions**
  3. **Section 7.43 Submittal of Shop Drawings, Product Data and Samples**
  4. **Section 7.49.1 Certificate of Compliance**
  5. **Appendix B Contract Data Requirements**
- B. Product Data: For each type of product indicated.
1. Submit product data indicating grounding equipment ratings and configurations.
- C. Shop Drawings:
1. Plans showing dimensioned as-built locations of grounding features specified in "Field Quality Control" Article. Indicate location of system grounding electrode connections, and routing of grounding electrode conductor. At a minimum included the following features:
    - a. Test wells.
    - b. Ground rods.
    - c. Ground rings.
    - d. Grounding connectors.
- D. Field quality-control reports.
- E. Closeout Submittals:
1. Project Record Documents:
    - a. Accurately record exact locations of neutral and equipment grounding points and grounding electrodes.

**1.04 QUALITY ASSURANCE**

- A. Electrical Components, Devices, and Accessories: Listed and labeled as defined in NFPA 70, by a qualified testing agency, and marked for intended location and application.
- B. Comply with UL 467 for grounding and bonding materials and equipment.

**1.05 REGULATORY REQUIREMENTS**

- A. Conform to and comply with IEEE C2.

**PART 2 – PRODUCTS**

**2.01 CONDUCTORS**

- A. Manufacturers: Subject to compliance with requirements provide products by one of the following:
  - 1. American Wire Group.
  - 2. National Strand Products.
  - 3. Southwire.
  - 4. Or approved equal.
- B. Insulated Conductors: tinned-copper wire or cable insulated for 600 V unless otherwise required by applicable Code or authorities having jurisdiction.
- C. Bare Copper Conductors:
  - 1. Solid Conductors: ASTM B 3.
  - 2. Stranded Conductors: ASTM B 8.
  - 3. Tinned Conductors: ASTM B 33.

**2.02 CONNECTORS**

- A. Manufacturers: Subject to compliance with requirements products by one of the following:
  - 1. Grounding Connectors, Exothermic:
    - a. Erico.
    - b. Harger
    - c. Or approved equal.
  - 2. Grounding Connectors, Irreversible Compression-Type:
    - a. FCI-Burndy “Hyground”.
    - b. Or approved equal.
  - 3. Grounding Connectors, Bolted:
    - a. Anderson (Hubbell).
    - b. FCI-Burndy.



- c. Thomas & Betts.
- d. Or approved equal.
- B. Listed and labeled by an NRTL acceptable to authorities having jurisdiction for applications in which used and for specific types, sizes, and combinations of conductors and other items connected.
- C. Bolted Connectors for Conductors and Pipes: Copper or copper alloy, pressure type with at least two bolts.  
Pipe Connectors: Clamp type, sized for pipe.
- D. Welded Connectors: Exothermic-welding kits of types recommended by kit manufacturer for materials being joined and installation conditions.
- E. Bus-bar Connectors: Mechanical type, cast silicon bronze, solderless compression or exothermic - type wire terminals, and long-barrel, two-bolt connection to ground bus bar.

## **2.03 GROUNDING ELECTRODES**

- A. Ground Rods: Copper encased steel, 3/4 inch diameter, minimum length minimum 10 feet.

## **PART 3 – EXECUTION**

### **3.01 APPLICATIONS**

- A. Conductors: Install solid conductor for No. 6 AWG and smaller, and stranded conductors for No. 6 AWG and larger unless otherwise indicated.
- B. Underground Grounding Conductors: Install bare copper conductor, No. 2/0AWG minimum.
  - 1. Bury at least 30 inches (760 mm) below grade.
- C. Conductor Terminations and Connections:
  - 1. Pipe and Equipment Grounding Conductor Terminations: Bolted connectors.
  - 2. Underground Connections: Other than at ground test wells, connections shall be by exothermic welding, Burndy Hyground irreversible compression-type connectors, or approved equal.
  - 3. Connections to Ground Rods at Test Wells: Bond conductor to ground rod using removable and replaceable bolted mechanical connectors.
  - 4. Connections to Structural Steel: Welded connectors.
  - 5. Main bonding jumpers, main bonding jumper cables connected to bus bars, terminals on transformers, switchboards, and service entrance equipment shall be terminated in two-hole 2 inch (13 mm) compression lugs.

### **3.02 EQUIPMENT GROUNDING**

- A. Provide a separate, 600 V insulated copper, equipment grounding conductor in all electrical raceways. Terminate each end on a grounding lug, bus, or bushing.

- B. Supplementary Grounding Electrode: Use driven ground rod on exterior of building in main service

### **3.03 INSTALLATION**

- A. Grounding Conductors: Route along shortest and straightest paths possible unless otherwise indicated or required by Code. Avoid obstructing access or placing conductors where they may be subjected to strain, impact, or damage.
- B. Ground Rods: Drive rods until tops are 2 inches (50 mm) below finished floor or final grade unless otherwise indicated.
  - 1. Interconnect ground rods with grounding electrode conductor below grade and as otherwise indicated. Make connections without exposing steel or damaging coating if any.
  - 2. For grounding electrode system, install at least three rods spaced at least one-rod length from each other and located at least the same distance from other grounding electrodes, and connect to the service grounding electrode conductor.
- C. Bonding Straps and Jumpers: Install in locations accessible for inspection and maintenance except where routed through short lengths of conduit.
  - 1. Bonding to Structure: Bond straps directly to basic structure, taking care not to penetrate any adjacent parts.
  - 2. Bonding to Equipment Mounted on Vibration Isolation Hangers and Supports: Install bonding so vibration is not transmitted to rigidly mounted equipment.
  - 3. Use exothermic welded connectors for outdoor locations; if a disconnect-type connection is required, use a bolted clamp.
- D. Grounding and Bonding for Piping:
  - 1. Bond each aboveground portion of gas piping system downstream from equipment shutoff valve.
- E. Grounding for Steel Building Structure: Install a driven ground rod at base of each corner column and at intermediate exterior columns at distances not more than 60 feet (18 m) apart.
- F. Comply with requirements in Section 26 05 53 "Identification for Electrical Systems" for instruction signs. The label or its text shall be green.

### **3.04 FIELD QUALITY CONTROL**

- A. Perform field inspection and testing in accordance with approved Contractor's Quality Control Plan.
- B. Tests and Inspection:
  - 1. After installing grounding system but before permanent electrical circuits have been energized, test for compliance with requirements.
  - 2. Inspect physical and mechanical condition. Verify tightness of accessible, bolted, electrical connections with a calibrated torque wrench according to manufacturer's written instructions.

3. Test maximum ground-resistance of completed grounding system.
    - a. Measure ground resistance no fewer than two full days after last trace of precipitation and without soil being moistened by any means other than natural drainage or seepage and without chemical treatment or other artificial means of reducing natural ground resistance.
    - b. Perform tests by fall-of-potential method according to IEEE 81.
    - c. For grounding resistors, use two points method test to determine resistance between main system and neutral.
  4. Prepare dimensioned drawings locating each test well, ground rod and ground-rod assembly, and other grounding electrodes. Identify each by letter in alphabetical order, and key to the record of tests and observations. Include the number of rods driven and their depth at each location, and include observations of weather and other phenomena that may affect test results. Describe measures taken to improve test results.
- C. Grounding system will be considered defective if it does not pass tests and inspections.
- D. Prepare test and inspection reports.
- E. Report measured ground resistances that exceed the following values:
1. Power and Lighting Equipment or System with Capacity of 500 kVA and less: 10 ohms.
- F. Excessive Ground Resistance: If resistance to ground exceeds specified values, notify VTA immediately and provide recommendations to reduce ground resistance.

**END OF SECTION 26 05 26**

*[This Page Intentionally Left Blank]*

## **SECTION 26 05 29 – HANGERS AND SUPPORTS FOR ELECTRICAL SYSTEMS**

### **PART 1 – GENERAL**

#### **1.01 SUMMARY**

- A. This Section includes the following:

Hangers and supports for electrical equipment and systems.

Construction requirements for concrete bases.

#### **1.02 RELATED SECTIONS**

- A. Technical Specifications Sections in Division 26 – Electrical

#### **1.03 DEFINITIONS**

- A. EMT: Electrical metallic tubing.  
B. RMC: Rigid metal conduit.

#### **1.04 SUBMITTALS**

- A. Submittal procedures must be in accordance with the applicable provisions of:

1. **Section 6.6 Contract Data Requirements**
2. **Section 7.41 Product Options, Supplier Approval and Substitutions**
3. **Section 7.43 Submittal of Shop Drawings, Product Data and Samples**
4. **Section 7.49.1 Certificate of Compliance**
5. **Appendix B Contract Data Requirements**

- B. Product Data: For the following:

1. Steel slotted support systems.
2. Nonmetallic slotted support systems.

- C. Shop Drawings: Signed and sealed by a qualified professional structural engineer. Show fabrication and installation details and include calculations for the following:

1. Trapeze hangers. Include Product Data for components.
2. Steel slotted channel systems. Include Product Data for components.
3. Nonmetallic slotted channel systems. Include Product Data for components.
4. Equipment supports.

#### **1.05 PERFORMANCE REQUIREMENTS**

- A. Design supports for multiple raceways capable of supporting combined weight of supported systems and its contents.

- B. Rated Strength: Adequate in tension, shear, and pullout force to resist maximum loads calculated or imposed for this Project, with a minimum structural safety factor of five times the applied force.

**1.06 QUALITY ASSURANCE**

- A. Comply with NFPA 70.

**1.07 COORDINATION**

- A. Coordinate size and location of "Emergency Stop Switch" support base. Cast anchor-bolt inserts into bases.

**PART 2 – PRODUCTS**

**2.01 SUPPORT, ANCHORAGE, AND ATTACHMENT COMPONENTS**

- A. Steel Slotted Support Systems: Comply with MFMA-4, factory-fabricated components for field assembly.
  - 1. Manufacturers: Subject to compliance with requirements, provide products by one of the following:
    - a. Allied Tube & Conduit.
    - b. Cooper B-Line, Inc.; a division of Cooper Industries.
    - c. ERICO International Corporation.
    - d. GS Metals Corp.
    - e. Thomas & Betts Corporation.
    - f. Unistrut; Tyco International, Ltd.
    - g. Wesanco, Inc.
    - h. Or approved equal.
  - 2. Metallic Coatings: Hot-dip galvanized after fabrication and applied according to MFMA-4.
  - 3. Nonmetallic Coatings: Manufacturer's standard PVC, polyurethane, or polyester coating applied according to MFMA-4.
  - 4. Painted Coatings: Manufacturer's standard painted coating applied according to MFMA-4.
  - 5. Channel Dimensions: Selected for applicable load criteria.
- B. Nonmetallic Slotted Support Systems: Structural-grade, factory-formed, glass-fiber-resin channels and angles with 9/16-inch diameter holes at a maximum of 8 inches o.c., in at least 1 surface.
  - 1. Manufacturers: Subject to compliance with requirements, provide products by one of the following:
    - a. Allied Tube & Conduit.

- b. Cooper B-Line, Inc.; a division of Cooper Industries.
  - c. Fabco Plastics Wholesale Limited.
  - d. Seasafe, Inc.
  - e. Or approved equal.
2. Fittings and Accessories: Products of channel and angle manufacturer and designed for use with those items.
  3. Fitting and Accessory Materials: Same as channels and angle.
  4. Rated Strength: Selected to suit applicable load criteria.
- C. Raceway and Cable Supports: As described in NECA 1 and NECA 101.
- D. Conduit and Cable Support Devices: Steel hangers, clamps, and associated fittings, designed for types and sizes of raceway or cable to be supported.
- E. Support for Conductors in Vertical Conduit: Factory-fabricated assembly consisting of threaded body and insulating wedging plug or plugs for non-armored electrical conductors or cables in riser conduits. Plugs shall have number, size, and shape of conductor gripping pieces as required to suit individual conductors or cables supported. Body shall be malleable iron.
- F. Structural Steel for Fabricated Supports and Restraints: ASTM A 36/A 36M, steel plates, shapes, and bars; black and galvanized.
- G. Mounting, Anchoring, and Attachment Components: Items for fastening electrical items or their supports to building surfaces include the following:
1. Powder-Actuated Fasteners: Threaded-steel stud, for use in hardened Portland cement concrete, steel, or wood, with tension, shear, and pullout capacities appropriate for supported loads and building materials where used.
    - a. Manufacturers: Subject to compliance with requirements, provide products by one of the following:
      - 1) Hilti Inc.
      - 2) ITW Ramset/Red Head; a division of Illinois Tool Works, Inc.
      - 3) MKT Fastening, LLC.
      - 4) Simpson Strong-Tie Co., Inc.; Masterset Fastening Systems Unit.
      - 5) Or approved equal.
  2. Mechanical-Expansion Anchors: Insert-wedge-type, stainless steel, for use in hardened Portland cement concrete with tension, shear, and pullout capacities appropriate for supported loads and building materials in which used.
    - a. Manufacturers: Subject to compliance with requirements, provide products by one of the following:
      - 1) Cooper B-Line, Inc.; a division of Cooper Industries.
      - 2) Empire Tool and Manufacturing Co., Inc.

- 3) Hilti Inc.
  - 4) ITW Ramset/Red Head; a division of Illinois Tool Works, Inc.
  - 5) MKT Fastening, LLC.
  - 6) Or approved equal.
3. Concrete Inserts: Steel or malleable-iron, slotted support system units similar to MSS Type 18; complying with MFMA-4 or MSS SP-58.
  4. Clamps for Attachment to Steel Structural Elements: MSS SP-58, type suitable for attached structural element.
  5. Through Bolts: Structural type, hex head, and high strength. Comply with ASTM A 325.
  6. Toggle Bolts: All-steel springhead type.
  7. Hanger Rods: Threaded steel.

### **PART 3 – EXECUTION**

#### **3.01 APPLICATION**

- A. Comply with NECA 1 and NECA 101 for application of hangers and supports for electrical equipment and systems except if requirements in this Section are stricter.
- B. Maximum Support Spacing and Minimum Hanger Rod Size for Raceway: Space supports for EMT and RMC as required by NFPA 70. Spacing between supports shall not exceed 10 feet in any case. Minimum rod size shall be 1/4 inch in diameter.
- C. Multiple Raceways or Cables: Install trapeze-type supports fabricated with steel slotted or other support system, sized so capacity can be increased by at least 25 percent in future without exceeding specified design load limits.
  1. Secure raceways and cables to these supports with two-bolt conduit clamps or single-bolt conduit clamps.
- D. Spring-steel clamps designed for supporting single conduits without bolts may be used for 1-1/2-inch and smaller raceways serving branch circuits and communication systems above suspended ceilings and for fastening raceways to trapeze supports.

#### **3.02 SUPPORT INSTALLATION**

- A. Comply with NECA 1 and NECA 101 for installation requirements except as specified in this Article.
- B. Raceway Support Methods: In addition to methods described in NECA EMT and RMC may be supported by openings through structure members, as permitted in NFPA 70.
- C. Strength of Support Assemblies: Where not indicated, select sizes of components so strength will be adequate to carry present and future static loads within specified loading limits. Minimum static design load used for strength determination shall be weight of supported components plus 200 lb.



- D. Mounting and Anchorage of Surface-Mounted Equipment and Components: Anchor and fasten electrical items and their supports to building structural elements by the following methods unless otherwise indicated by code:
  - 1. To Wood: Fasten with lag screws or through bolts.
  - 2. To New Concrete: Bolt to concrete inserts using precast insert system or preset inserts.
  - 3. To Masonry: Approved toggle-type bolts or hollow wall fasteners in hollow masonry, plaster, or gypsum board partitions and walls; expansion anchor fasteners or preset inserts on solid masonry units.
  - 4. To Existing Concrete: Expansion anchor fasteners or self-drilling anchor fasteners. Do not use powder-actuated anchors without prior written permission from VTA.
  - 5. Instead of expansion anchors, powder-actuated driven threaded studs provided with lock washers and nuts may be used in existing standard-weight concrete 4 inches thick or greater. Do not use for anchorage to lightweight-aggregate concrete or for slabs less than 4 inches thick.
  - 6. Items Mounted on Hollow Walls and Nonstructural Building Surfaces: Mount cabinets, panelboards, disconnect switches, control enclosures, pull and junction boxes, transformers, and other devices on slotted-channel racks attached to substrate by means that meet seismic-restraint strength and anchorage requirements.
- E. Drill holes for expansion anchors in concrete at locations and to depths that avoid reinforcing bars.
- F. Do not fasten supports to piping, ductwork, mechanical equipment, or conduit.
- G. Do not drill structural steel members without written permission from VTA.
- H. In wet locations, install free standing electrical equipment on concrete pads.
- I. Install surface mounted cabinets and panelboards with at least four anchors. Provide steel channel supports to stand cabinet 1 inch off wall.
- J. Bridge studs top and bottom with channels to support flush mounted cabinets and panelboards in stud walls.

### **3.03 PAINTING**

- A. Touchup: Clean field welds and abraded areas of shop paint. Paint exposed areas immediately after erecting hangers and supports. Use same materials as used for shop painting. Comply with SSPC-PA 1 requirements for touching up field-painted surfaces.  
Apply paint by brush or spray to provide minimum dry film thickness of 2.0 mils.
- B. Touchup: Comply with requirements in Section 09 91 23 Painting for cleaning and touchup painting.
- C. Galvanized Surfaces: Clean welds, bolted connections, and abraded areas and apply galvanizing-repair paint to comply with ASTM A780.

**END OF SECTION 26 05 29**

*[This Page Intentionally Left Blank]*

## **SECTION 26 05 33 – RACEWAYS AND BOXES FOR ELECTRICAL SYSTEMS**

### **PART 1 – GENERAL**

#### **1.01 SUMMARY**

- A. Section Includes:
1. Metal conduits, tubing, and fittings.
  2. Nonmetal conduits, tubing, and fittings.
  3. Boxes, enclosures, and cabinets.
  4. Handholes and boxes for exterior underground cabling.

#### **1.02 RELATED SECTIONS**

- A. Technical Specifications Sections in Division 26 - Electrical

#### **1.03 DEFINITIONS**

- A. ARC: Aluminum rigid conduit.  
B. GRC: Galvanized rigid steel conduit.

#### **1.04 SUBMITTALS**

- A. Submittal procedures must be in accordance with the applicable provisions of:
1. **Section 6.6 Contract Data Requirements**
  2. **Section 7.41 Product Options, Supplier Approval and Substitutions**
  3. **Section 7.43 Submittal of Shop Drawings, Product Data and Samples**
  4. **Section 7.49.1 Certificate of Compliance**
  5. **Appendix B Contract Data Requirements**
- B. Product Data: For surface raceways, wireways and fittings, floor boxes, hinged-cover enclosures, cabinets, and equipment panels. Include manufacturer's installation instructions.
- C. Shop Drawings: For custom enclosures and cabinets; include plans, elevations, sections, and attachment details.
- D. Coordination Drawings: Conduit routing plans, drawn to scale, on which the following items are shown and coordinated with each other, using input from installers of items involved:
1. Structural members in paths of conduit groups with common supports.
  2. Plumbing items and architectural features in paths of conduit groups with common supports.
- E. Qualification Data: For professional engineer.
- F. Seismic Qualification Certificates: For enclosures and conduit racks and their mounting provisions, including those for internal components from manufacturer.

1. Dimensioned Outline Drawings of Equipment Unit: Identify center of gravity and locate and describe mounting and anchorage provisions.
2. Detailed description of conduit support devices and interconnections on which the certification is based and their installation requirements.

## **PART 2 – PRODUCTS**

### **2.01 METAL CONDUITS, TUBING, AND FITTINGS**

- A. Manufacturers: Subject to compliance with requirements, provide products by one of the following:
  1. AFC Cable Systems, Inc.
  2. Allied Tube & Conduit; a Tyco International Ltd. Co.
  3. Anamet Electrical, Inc.
  4. Electri-Flex Company.
  5. O-Z/Gedney; a brand of EGS Electrical Group.
  6. Picoma Industries, a subsidiary of Mueller Water Products, Inc.
  7. Republic Conduit.
  8. Robroy Industries.
  9. Southwire Company.
  10. Thomas & Betts Corporation.
  11. Western Tube and Conduit Corporation.
  12. Wheatland Tube Company; a division of John Maneely Company.
  13. Or approved equal.
- B. Listing and Labeling: Metal conduits, tubing, and fittings shall be listed and labeled as defined in NFPA 70, by a qualified testing agency, and marked for intended location and application.
- C. GRC: Comply with ANSI C80.1 and UL 6. Full-weight pipe with threaded ends, and protected inside with corrosion resistant coating, outside with hot dip galvanizing.
- D. ARC: Comply with ANSI C80.5 and UL 6A. Full-weight pipe, built to the same standards as rigid steel conduit with threaded ends; Kaiser "Kingfisher," Reynolds, or approved equal.
- E. PVC-Coated Steel Conduit: PVC-coated rigid steel conduit.
  1. Comply with NEMA RN 1.
  2. Coating Thickness: 0.020 inch minimum.
  3. Internal galvanized surface.
- F. EMT:
  1. Comply with ANSI C80.3 and UL 797.

2. Lightweight thin wall conduit, rigid steel, electro-galvanized and enameled on the inside.
- G. FMC:
1. Comply with UL Defense Logistics Center DLA A-A-55810.
  2. Zinc-coated steel or aluminum.
  3. Interlocking single-strip type.
- H. LFMC:
1. Comply with UL 360.
  2. Liquid-tight, interlocking single-strip type with overall molded PVC jacket to exclude moisture.
- I. Fittings for Metal Conduit: Comply with NEMA FB 1 and UL 514B.
1. Conduit Fittings for Hazardous (Classified) Locations: Comply with UL 886 and NFPA 70.
  2. Fittings for EMT:
    - a. Material: Steel
    - b. Type: Compression. Set-screw or crimp-on type fittings are not acceptable.
  3. Expansion Fittings: PVC or steel to match conduit type, complying with UL 651, rated for environmental conditions where installed, and including flexible external bonding jumper.
  4. Coating for Fittings for PVC-Coated Conduit: Minimum thickness of 0.040 inch, with overlapping sleeves protecting threaded joints.
- J. Joint Compound for GRC or ARC: Approved, as defined in NFPA 70, by authorities having jurisdiction for use in conduit assemblies, and compounded for use to lubricate and protect threaded conduit joints from corrosion and to enhance their conductivity.

## **2.02 BOXES AND ENCLOSURES**

- A. Manufacturers: Subject to compliance with requirements, products by one of the following:
1. Adalet.
  2. Cooper Technologies Company; Cooper Crouse-Hinds.
  3. EGS/Appleton Electric.
  4. Erickson Electrical Equipment Company.
  5. FSR Inc.
  6. Hoffman; a Pentair company.
  7. Hubbell Incorporated; Killark Division.
  8. Kraloy.
  9. Milbank Manufacturing Co.
  10. Mono-Systems, Inc.

11. O-Z/Gedney; a brand of EGS Electrical Group.
  12. RACO; a Hubbell Company.
  13. Robroy Industries.
  14. Spring City Electrical Manufacturing Company.
  15. Stahlin Non-Metallic Enclosures; a division of Robroy Industries.
  16. Thomas & Betts Corporation.
  17. Wiremold / Legrand.
  18. Or approved equal.
- B. General Requirements for Boxes, Enclosures, and Cabinets:
1. Boxes, enclosures, and cabinets installed in wet locations shall be listed for use in wet locations.
  2. All outlet boxes shall be of the shape and size best suited to the particular location, and of sufficient size to contain all wires, connections, and devices without crowding. Minimum size shall be 4-inches (nominal) by 1 1/2 inches deep.
- C. Sheet Steel Outlet and Device Boxes:
1. Comply with NEMA OS 1 and UL 514A.
  2. Standard knock-out boxes of pressed or stamped sheet steel; sherardized or galvanized; with 1/2 inch male fixture studs where required; number and size of knock-outs to suit requirements of location and use.
- D. Cast-Metal Outlet and Device Boxes: Comply with NEMA FB 1, Steel or aluminum, Type FD, with threaded hubs and gasketed covers suitable for the use and the location.
- E. Cast Metal Boxes for Outdoor and Wet Locations: NEMA 250 type 4 and type 6; galvanized cast-iron; flat flanged for surface mounting; with neoprene gasket, stainless-steel cover screws, and cover in material to match box; and listed as raintight by any nationally recognized testing laboratory (NRTL) recognized under 29 CFR 1910.7.
- F. Concealed Ceiling Boxes: A 4-inch square or 4-inch octagon, with raised cover, set to suit construction conditions.
- G. Nonmetallic Outlet and Device Boxes: Comply with NEMA OS 2 and UL 514C.
- H. Pull and Junction Boxes:
1. Use outlet boxes as specified above wherever possible for pull and junction boxes.
  2. Where larger sizes are required, build pull boxes of galvanized sheet steel in required gauge in accordance with NEMA OS 1; in sizes noted on the Contract Drawings or approved by VTA; with required knock-outs or hubs. Covers shall line up evenly with edges of boxes.
  3. Sheet metal boxes larger than 12 inches in any dimension shall be built as a hinged enclosure in accordance with the requirements described elsewhere in this Section.

- I. Small Sheet Metal Pull and Junction Boxes: NEMA OS 1.
- J. Cast-Metal Access, Pull, and Junction Boxes: Comply with NEMA FB 1 and UL 1773, cast aluminum or galvanized, cast iron with gasketed cover.
- K. Box extensions used to accommodate new building finishes shall be of same material as recessed box.
- L. Device Box Dimensions: 4 inches square by 2-1/8 inches deep.
- M. Gangable boxes are prohibited.
- N. Hinged-Cover Enclosures: Comply with UL 50 and NEMA 250, Type 1 Type 3R with continuous-hinge cover with key-operated flush latch unless otherwise indicated.
  - 1. Metal Enclosures: Steel, finished inside and out with manufacturer's standard enamel.
  - 2. Nonmetallic Enclosures: Fiberglass.
  - 3. Interior Panels: Steel, 14-gauge; all sides finished with manufacturer's standard white enamel.
- O. Cabinets:
  - 1. NEMA 250, Type 1 or Type 3R galvanized-steel box with removable end walls, removable interior panel and removable front, as specified on contract documents finished inside and out with manufacturer's standard grey baked enamel.
  - 2. Hinged door in front cover with flush latch and concealed hinge.
  - 3. Flush lock keyed to match branch circuit panelboard.
  - 4. Metal barriers to separate wiring of different systems and voltage.
  - 5. Accessory feet where required for freestanding equipment.
  - 6. Nonmetallic cabinets shall be listed and labeled as defined in NFPA 70, by a qualified testing agency, and marked for intended location and application.
- P. Terminal Blocks and Accessories for Hinged Cover Enclosures and Cabinets:
  - 1. Terminal Blocks: NEMA ICS 4; listed by any nationally recognized testing laboratory (NRTL) recognized under 29 CFR 1910.7 for the intended use.
  - 2. Power Terminals: Unit construction type, closed back, with tubular pressure screw connectors, rated 600 V.
  - 3. Signal and Control Terminals: Modular construction type, channel mounted; tubular pressure screw connectors, rated 300 V.
- Q. Fabrication of Hinged Cover Enclosures and Cabinets Housing Terminal Blocks or Electrical Components:
  - 1. Shop assemble enclosures and cabinets housing terminal blocks or electrical components in accordance with NEMA ICS 6.
  - 2. Provide conduit hubs on enclosures.

3. Provide protective pocket inside front cover with schematic diagram, connection diagram, and layout drawing of control wiring and components within enclosure.

### **2.03 UTILITY BOXES FOR EXTERIOR UNDERGROUND WIRING**

- A. General Requirements for Utility Boxes:
1. Boxes and Handholes for use in underground systems shall be designed and identified as defined in NFPA 70, for intended location and application.
  2. Boxes installed in wet areas shall be listed and labeled as defined in NFPA 70, by a qualified testing agency, and marked for intended location and application.
- B. Cast Metal Boxes for Underground Installations: NEMA 250 type 4; galvanized cast iron, cast aluminum flanged for recessed mounting; with neoprene gasket, stainless-steel cover screws, and plain recessed cover in material to match box; and listed as raintight by any NRTL.
- C. Polymer-Concrete Handholes and Boxes with Polymer-Concrete Cover: Molded of sand and aggregate, bound together with polymer resin, and reinforced with steel, fiberglass, or a combination of the two.
1. Manufacturers: Subject to compliance with requirements, provide products by one of the following:
    - a. Armorcast Products Company.
    - b. Carson Industries LLC.
    - c. CDR Systems Corporation; Hubbell Power Systems.
    - d. New Basis.
    - e. Oldcastle Precast, Inc.; Christy Concrete Products.
    - f. Synertech Molded Products; a division of Oldcastle Precast, Inc.
    - g. Or approved equal.
  2. Standard: Comply with SCTE 77.
  3. Configuration: Designed for flush burial with open bottom unless otherwise indicated.
  4. Cover: Weatherproof, secured by tamper-resistant locking devices and having structural load rating consistent with enclosure and handhole location.
  5. Cover Finish: Nonskid finish shall have a minimum coefficient of friction of 0.50.
  6. Cover Legend: Molded lettering, "ELECTRIC", as specified on Contract Drawings, or as approved by VTA.
  7. Conduit Entrance Provisions: Conduit-terminating fittings shall mate with entering ducts for secure, fixed installation in enclosure wall.
- D. Fiberglass Handholes and Boxes: Die-molded of fiberglass-reinforced polyester resin, with frame and covers of polymer concrete.
1. Manufacturers: Subject to compliance with requirements provide products by one of the following:



- a. Armorcast Products Company.
  - b. Carson Industries LLC.
  - c. CDR Systems Corporation; Hubbell Power Systems.
  - d. New Basis.
  - e. Nordic Fiberglass, Inc.
  - f. Oldcastle Precast, Inc.; Christy Concrete Products.
  - g. Synertech Molded Products; a division of Oldcastle Precast, Inc.
  - h. Or approved equal.
2. Standard: Comply with SCTE 77.
  3. Color of Frame and Covers as shown on contract documents.
  4. Configuration: Designed for flush burial with open bottom unless otherwise indicated.
    - a. Open bottom configuration shall have precut 6-inch by 6-inch cable entrance at center bottom of each side.
  5. Cover: Weatherproof, secured by tamper-resistant locking devices and having structural load rating consistent with enclosure and Handhole location.
  6. Cover Finish: Nonskid finish shall have a minimum coefficient of friction of 0.50.
  7. Cover Legend: Molded lettering, "ELECTRIC", as specified on Contract Drawings, or as approved by VTA.
  8. Conduit Entrance Provisions: Conduit-terminating fittings shall mate with entering ducts for secure, fixed installation in enclosure wall.
  9. Handholes 2 Inches Wide by 24 Inches Long and Larger: Have inserts for cable racks and pulling-in irons installed before concrete is poured.

#### **2.04 SOURCE QUALITY CONTROL FOR UNDERGROUND ENCLOSURES**

- A. Pull-Box Prototype Test: Test prototypes of boxes for compliance with SCTE 77. Strength tests shall be for specified tier ratings of products supplied.
  1. Tests of materials shall be performed by an independent testing agency.
  2. Strength tests of complete boxes and covers shall be by either an independent testing agency or manufacturer. A qualified registered professional engineer shall certify tests by manufacturer.
  3. Testing machine pressure gages shall have current calibration certification complying with ISO 9000 and ISO 10012 and traceable to NIST standards.

### **PART 3 – EXECUTION**

#### **3.01 RACEWAY APPLICATION**

- A. Installations In Underground Within 5 Feet of Foundation Wall: Schedule 40 PVC conduit .

- B. Exposed Outdoor Locations: Rigid steel conduit. Galvanized EMT with fittings approved for wet locations and protected from corrosion may be used in lieu of rigid steel conduit.
- C. Wet Interior Locations: Rigid steel conduit. Galvanized EMT with fittings approved for wet locations and protected from corrosion may be used in lieu of rigid steel conduit.
- D. Exposed Dry Interior Locations: Electrical Metallic Tubing (EMT) may be used in lieu of rigid conduit for exposed work at least 6 feet above finished floor indoors.
- E. Raceway Connections to Motors and Vibrating Equipment (Including Transformers and Hydraulic, Pneumatic, Electric Solenoid, or Motor-Driven Equipment): Liquidtight flexible metal conduit.
- F. Outdoor Boxes and Enclosures, Aboveground: NEMA 250, Type 3R.
- G. Indoor Boxes and Enclosures: NEMA 250, Type 1, except use NEMA 250, Type 4 stainless steel, nonmetallic in institutional and commercial kitchens and damp or wet locations.
- H. Minimum Raceway Size:
  - 1. 3/4-inch.
  - 2. Trade size.
  - 3. For Conduit Cast-in-Concrete or Below Grade: 1 inch. Do not route conduit to cross each other in concrete slabs.
- I. Raceway Fittings: Compatible with raceways and suitable for use and location.
  - 1. Rigid and Intermediate Steel Conduit: Use threaded rigid steel conduit fittings unless otherwise indicated. Comply with NEMA FB 2.10.
  - 2. PVC Externally Coated, Rigid Steel Conduits: Use only fittings listed for use with this type of conduit. Patch and seal all joints, nicks, and scrapes in PVC coating after installing conduits and fittings. Use sealant recommended by fitting manufacturer and apply in thickness and number of coats recommended by manufacturer.
  - 3. EMT: Use compression steel fittings. Comply with NEMA FB 2.10.
  - 4. Flexible Conduit: Use only fittings listed for use with flexible conduit. Comply with NEMA FB 2.20.
- J. Do not install aluminum conduits, boxes, or fittings in contact with concrete or earth.
- K. Install surface raceways only where indicated on Contract Drawings.
- L. Do not install nonmetallic conduit where ambient temperature exceeds 120 deg F.

### **3.02 INSTALLATION OF CONDUIT AND SURFACE RACEWAY**

- A. Comply with NECA 1 and NECA 101 for installation requirements except where requirements on Contract Drawings or in this article are stricter. Comply with NECA 102 for aluminum conduits. Comply with NFPA 70 limitations for types of raceways allowed in specific occupancies and number of floors.

- B. Maintain at least 6 inch clearance between conduit and piping. Maintain 12 inch clearance between conduit and heat sources such as flues, steam pipes, and heating appliances. Maintain 18 inch clearance above roof.
- C. Complete raceway installation before starting conductor installation.
- D. Comply with requirements in Section 260529 "Hangers and Supports for Electrical Systems" for hangers and supports.
- E. Arrange conduit to maintain required headroom and present a neat appearance.
- F. Conceal conduit and EMT within finished walls, ceilings, and floors unless otherwise indicated. Install conduits parallel or perpendicular to building lines.
- G. Route exposed conduit and conduit above accessible ceilings parallel or perpendicular to walls and structural members, with right-angle turns consisting of symmetrical bends or cast metal fittings. Route conduit to avoid access openings, access to equipment, and like items.
- H. Arrange stub-ups so curved portions of bends are not visible above finished slab.
- I. Arrange conduit supports to prevent distortion of alignment by wire pulling operations. Fasten conduit using galvanized straps, lay in adjustable hangers, clevis hangers, or bolted, split, stamped galvanized hangers.
- J. Do not fasten conduit with wire or perforated pipe straps. Before conductors are pulled, remove all wire used for temporary conduit support during construction.
- K. Group conduit in parallel runs where practical and use conduit rack constructed of steel channel with conduit straps or clamps. Provide space for 25% additional conduit.
- L. Conduit supports shall be spaced at no more than 10 feet on center.
- M. Install no more than the equivalent of three 90-degree bends in any conduit run except for control wiring conduits, for which fewer bends are allowed. Support within 12 inches of changes in direction.
- N. Support conduit within 12 inches of enclosures to which attached.
- O. Cut conduit square using saw or pipe cutter; deburr cut ends.
- P. Bring conduit to shoulder of fittings and couplings and fasten securely.
- Q. Use conduit hubs or sealing locknuts for fastening conduit to cast boxes and for fastening conduit to sheet metal boxes in damp or wet locations.
- R. Use conduit bodies to make sharp changes in direction, as around beams.
- S. Use standard tools and equipment manufactured especially for the purpose of making field bends in rigid conduit or EMT. Bends shall not have a radius less than allowed by NFPA 70. Ensure that the bends are free of kinks, indentations, or flattened areas. Heating conduit for any purpose is prohibited.
- T. Avoid moisture traps; where unavoidable, provide junction box with drain fitting at conduit low point.
- U. Use suitable conduit caps to protect installed conduit against entrance of dirt and moisture.
- V. Stub-ups to Above Recessed Ceilings:  
Use EMT or RMC for raceways.

- Use a conduit bushing or insulated fitting to terminate stub-ups not terminated in hubs or
- W. Threaded Conduit Joints, Exposed to Wet, Damp, Corrosive, or Outdoor Conditions: Apply listed compound to threads of raceway and fittings before making up joints. Follow compound manufacturer's written instructions.
  - X. Coat field-cut threads on PVC-coated raceway with a corrosion-preventing conductive compound prior to assembly.
  - Y. Raceway Terminations at Locations Subject to Moisture or Vibration: Use insulating bushings to protect conductors including conductors smaller than No. 4 AWG.
  - Z. Terminate threaded conduits into threaded hubs or with locknuts on inside and outside of boxes or cabinets. Install bushings on conduits up to 1-1/4-inch trade size and insulated throat metal bushings on 1-1/2-inch trade size and larger conduits terminated with locknuts. Install insulated throat metal grounding bushings on service conduits.
  - AA. Install raceways square to the enclosure and terminate at enclosures with locknuts. Install locknuts hand tight plus 1/4 turn more.
  - BB. Do not rely on locknuts to penetrate nonconductive coatings on enclosures. Remove coatings in the locknut area prior to assembling conduit to enclosure to assure a continuous ground path.
  - CC. Cut conduit perpendicular to the length. For conduits 2-inch trade size and larger, use roll cutter or a guide to make cut straight and perpendicular to the length.
  - DD. Install pull cords in empty raceways. Use polypropylene or monofilament plastic line with not less than 200-lb tensile strength. Leave at least 12 inches of slack at each end of pull wire. Identify both ends of all pull cords by label or tag that reads "Pull Cord." Cap underground raceways designated as spare above grade alongside raceways in use.
  - EE. Stubs: Connect all motor terminal boxes to conduit stubs or outlets with flexible conduit. Where motors are mounted on adjustable bases, ensure that the flexible connection is of sufficient length to allow full adjustment of the motor.
  - FF. Place conduit stub-ups where dimensioned on the Contract Drawings or as approved by VTA.
  - GG. Fit conduit stub-ups located in open floor areas or under removable partitions, with a full coupling, the top edge of which shall be flush with the finish floor surface. Seal couplings with flush, threaded plugs.
  - HH. Terminate underground conduit stubbed above-grade, with a coupling and threaded iron pipe plug.

### **3.03 INSTALLATION OF BOXES**

- A. Provide electrical boxes as shown on the Contract Drawings, and as required for splices, taps, wire pulling, equipment connections, and code compliance.
- B. Electrical box locations shown on the Contract Drawings are approximate unless dimensioned. Verify location of floor boxes and outlets in offices and work areas prior to rough in.

- C. Locate and install boxes to allow access. Locate pull boxes and junction boxes above accessible ceilings or in unfinished areas. Where installation is inaccessible, provide access doors of appropriate size and location.
- D. Locate and install to maintain required headroom and to present a neat appearance.
- E. Mount boxes at heights indicated on Contract Drawings. If mounting heights of boxes are not individually indicated, give priority to ADA requirements. Install boxes with height measured to center of box unless otherwise indicated.
- F. Locate boxes so that cover or plate will not span different building finishes.
- G. Support boxes independently of conduit except for cast boxes that are connected to two rigid metal conduits, both supported within 12 inches of box. Fasten boxes with screws or support with hangers.
- H. Do not install boxes back to back in walls; provide at least 6 inch separation. Provide at least 24 inch separation in acoustic rated walls.
- I. Provide knock out closures for unused openings.
- J. Install boxes in walls without damaging wall insulation.
- K. Provide cast outlet boxes in exterior locations exposed to the weather and wet locations.

#### **3.04 INSTALLATION OF CABINETS AND ENCLOSURES**

- A. Install cabinets and enclosures plumb; anchor securely to wall and provide structural supports at least at each corner.
- B. Install trim square and plumb.

#### **3.05 INSTALLATION OF UNDERGROUND CONDUIT**

- A. Direct-Buried Conduit:
  - 1. Excavate trench bottom to provide firm and uniform support for conduit. Prepare trench bottom per Contract Drawings.
  - 2. Install backfill per Contract Drawings.
  - 3. After installing conduit, backfill and compact. Start at tie-in point, and work toward end of conduit run, leaving conduit at end of run free to move with expansion and contraction as temperature changes during this process. Firmly hand tamp backfill around conduit to provide maximum supporting strength. After placing controlled backfill to within 12 inches of finished grade, make final conduit connection at end of run and complete backfilling with normal compaction as specified on Contract Drawings.
  - 4. Install manufactured duct elbows for stub-ups at poles and equipment and at building entrances through floor unless otherwise indicated. Encase elbows for stub-up ducts throughout length of elbow.
  - 5. Install manufactured rigid steel conduit elbows for stub-ups at poles and equipment and at building entrances through floor.

- a. Couple steel conduits to ducts with adapters designed for this purpose, and encase coupling with 3 inches of concrete for a minimum of 12 inches on each side of the coupling.
  - b. For stub-ups at equipment mounted on outdoor concrete bases and where conduits penetrate building foundations, extend steel conduit horizontally a minimum of 60 inches from edge of foundation or equipment base. Install insulated grounding bushings on terminations at equipment.
6. Underground Warning Tape and Marker Balls: Comply with requirements in Section 26 05 53 - Identification for Electrical Systems.

### **3.06 INSTALLATION OF UNDERGROUND HANDHOLES AND BOXES**

- A. Install handholes and boxes level and plumb and with orientation and depth coordinated with connecting conduits to minimize bends and deflections required for proper entrances.
- B. Unless otherwise indicated, support units on a level bed of crushed stone or gravel, graded from 1/2-inch sieve to No. 4 sieve and compacted to same density as adjacent undisturbed earth.
- C. Elevation: In paved areas, set so cover surface will be flush with finished grade. Set covers of other enclosures 1 inch above finished grade.
- D. Install handholes with bottom below frost line.
- E. Install removable hardware, including pulling eyes, cable stanchions, cable arms, and insulators, as required for installation and support of cables and conductors and as indicated. Select arm lengths to be long enough to provide spare space for future cables but short enough to preserve adequate working clearances in enclosure.
- F. Field-cut openings for conduits according to enclosure manufacturer's written instructions. Cut wall of enclosure with a tool designed for material to be cut. Size holes for terminating fittings to be used, and seal around penetrations after fittings are installed.

### **3.07 SLEEVE AND SLEEVE-SEAL INSTALLATION FOR ELECTRICAL PENETRATIONS**

- A. Install sleeves and sleeve seals at penetrations of exterior floor and wall assemblies. Comply with requirements in Section 26 05 44 - Sleeves and Sleeve Seals for Electrical Raceways and Cabling.

### **3.08 FIRESTOPPING**

- A. Where conduit penetrates fire rated walls and floors, provide pipe sleeve two sizes larger than conduit; pack void around conduit with oakum and fill ends of sleeve with fire resistive compound. Provide mechanical fire stop fittings with fire rating equal to wall or floor rating, and listed by any nationally recognized testing laboratory (NRTL) recognized under 29 CFR 1910.7. 3 seal opening around conduit with foamed silicone elastomer compound listed by any nationally recognized testing laboratory (NRTL) recognized under 29 CFR 1910.7.
- B. Install firestopping at penetrations of fire-rated floor and wall assemblies.

### **3.09 PROTECTION**

- A. Protect coatings, finishes, and cabinets from damage and deterioration.

1. Repair damage to galvanized finishes with zinc-rich paint recommended by manufacturer.
2. Repair damage to PVC coatings or paint finishes with matching touchup coating recommended by manufacturer.

**END OF SECTION 26 05 33**

*[This Page Intentionally Left Blank]*



## **SECTION 26 05 44 – SLEEVES AND SLEEVE SEALS FOR ELECTRICAL RACEWAYS AND CABLING**

### **PART 1 – GENERAL**

#### **1.01 SUMMARY**

A. Section Includes:

1. Sleeves for raceway and cable penetration of non-fire-rated construction walls and floors.
2. Sleeve-seal systems.
3. Sleeve-seal fittings.
4. Grout.
5. Silicone sealants.

#### **1.02 RELATED SECTIONS**

- A. Technical Specifications Sections in Division 26 – Electrical

#### **1.03 SUBMITTALS**

A. Submittal procedures must be in accordance with the applicable provisions of:

1. **Section 6.6 Contract Data Requirements**
2. **Section 7.41 Product Options, Supplier Approval and Substitutions**
3. **Section 7.43 Submittal of Shop Drawings, Product Data and Samples**
4. **Section 7.49.1 Certificate of Compliance**
5. **Appendix B Contract Data Requirements**

- B. Product Data: For each type of product.

### **PART 2 – PRODUCTS**

#### **2.01 SLEEVES**

A. Wall Sleeves:

1. Steel Pipe Sleeves: ASTM A 53/A 53M, Type E, Grade B, Schedule 40, zinc coated, plain ends.
2. Cast-Iron Pipe Sleeves: Cast or fabricated "wall pipe," equivalent to ductile-iron pressure pipe, with plain ends and integral waterstop unless otherwise indicated.

- B. Sleeves for Conduits Penetrating Non-Fire-Rated Gypsum Board Assemblies: Galvanized-steel sheet; 0.0239-inch minimum thickness; round tube closed with welded longitudinal joint, with tabs for screw-fastening the sleeve to the board.

- C. PVC-Pipe Sleeves: ASTM D 1785, Schedule 40.

- D. Molded-PVC Sleeves: With nailing flange for attaching to wooden forms.

- E. Molded-PE or -PP Sleeves: Removable, tapered-cup shaped, and smooth outer surface with nailing flange for attaching to wooden forms.
- F. Sleeves for Rectangular Openings:
  - 1. Material: Galvanized sheet steel.
  - 2. Minimum Metal Thickness:
    - a. For sleeve cross-section rectangle perimeter less than 50 inches and with no side larger than 16 inches thickness shall be 0.052 inch
    - b. For sleeve cross-section rectangle perimeter 50 inches or more and one or more sides larger than 16 inches thickness shall be 0.138 inch.

## **2.02 SLEEVE-SEAL SYSTEMS**

- A. Description: Modular sealing device, designed for field assembly, to fill annular space between sleeve and raceway or cable.
  - 1. Manufacturers: Subject to compliance with requirements, provide products by the following or provide products by one of the following:
    - a. Advance Products & Systems, Inc.
    - b. CALPICO, Inc.
    - c. Metraflex Company (The).
    - d. Pipeline Seal and Insulator, Inc.
    - e. Proco Products, Inc.
    - f. Or approved equal.
  - 2. Sealing Elements: EPDM or Nitrile (Buna N) rubber interlocking links shaped to fit surface of pipe. Include type and number required for pipe material and size of pipe.
  - 3. Pressure Plates: Carbon steel or Plastic or Stainless steel.
  - 4. Connecting Bolts and Nuts: Carbon steel, with corrosion-resistant coating, Stainless steel of length required to secure pressure plates to sealing elements.

## **2.03 SLEEVE-SEAL FITTINGS**

- A. Description: Manufactured plastic, sleeve-type, waterstop assembly made for embedding in concrete slab or wall. Unit shall have plastic or rubber waterstop collar with center opening to match piping OD.
  - 1. Manufacturers: Subject to compliance with requirements, provide products by the following or provide products by one of the following:
    - a. Presealed Systems.
    - b. Or approved equal.

## **2.04 GROUT**

- A. Description: Nonshrink; recommended for interior and exterior sealing openings in non-fire-rated walls or floors.
- B. Standard: ASTM C 1107/C 1107M, Grade B, post-hardening and volume-adjusting, dry, hydraulic-cement grout.
- C. Design Mix: 5000-psi (34.5-MPa), 28-day compressive strength.
- D. Packaging: Premixed and factory packaged.

## **2.05 SILICONE SEALANTS**

- A. Silicone Sealants: Single-component, silicone-based, neutral-curing elastomeric sealants of grade indicated below.
  - 1. Grade: Pourable (self-leveling) formulation for openings in floors and other horizontal surfaces that are not fire rated.
  - 2. Sealant shall have VOC content meeting requirements of the Bay Area Air Quality Management District.
- B. Silicone Foams: Multicomponent, silicone-based liquid elastomers that, when mixed, expand and cure in place to produce a flexible, nonshrinking foam.

## **PART 3 – EXECUTION**

### **3.01 SLEEVE INSTALLATION FOR NON-FIRE-RATED ELECTRICAL PENETRATIONS**

- A. Comply with NECA 1.
- B. Comply with NEMA VE 2 for cable tray and cable penetrations.
- C. Sleeves for Conduits Penetrating Above-Grade Non-Fire-Rated Concrete and Masonry-Unit Floors and Walls:
  - 1. Interior Penetrations of Non-Fire-Rated Walls and Floors:
    - a. Seal annular space between sleeve and raceway or cable, using joint sealant appropriate for size, depth, and location of joint.
    - b. Seal space outside of sleeves with mortar or grout. Pack sealing material solidly between sleeve and wall so no voids remain. Tool exposed surfaces smooth; protect material while curing.
  - 2. Use pipe sleeves unless penetration arrangement requires rectangular sleeved opening.
  - 3. Size pipe sleeves to provide 1/4-inch annular clear space between sleeve and raceway or cable unless sleeve seal is to be installed or unless seismic criteria require different clearance.
  - 4. Install sleeves for wall penetrations unless core-drilled holes or formed openings are used. Install sleeves during erection of walls. Cut sleeves to length for mounting flush with both surfaces of walls. Deburr after cutting.

- D. Sleeves for Conduits Penetrating Non-Fire-Rated Gypsum Board Assemblies:
  - 1. Use circular metal sleeves unless penetration arrangement requires rectangular sleeved opening.
  - 2. Seal space outside of sleeves with approved joint compound for gypsum board assemblies.
- E. Roof-Penetration Sleeves: Seal penetration of individual raceways and cables with flexible boot-type flashing units applied in coordination with roofing work.
- F. Aboveground, Exterior-Wall Penetrations: Seal penetrations using steel or cast-iron pipe sleeves and mechanical sleeve seals. Select sleeve size to allow for 1-inch annular clear space between pipe and sleeve for installing mechanical sleeve seals.
- G. Underground, Exterior-Wall and Floor Penetrations: Install cast-iron pipe sleeves. Size sleeves to allow for 1-inch annular clear space between raceway or cable and sleeve for installing sleeve-seal system.

### **3.02 SLEEVE-SEAL-SYSTEM INSTALLATION**

- A. Install sleeve-seal systems in sleeves in exterior concrete walls and slabs-on-grade at raceway entries into building.
- B. Install type and number of sealing elements recommended by manufacturer for raceway or cable material and size. Position raceway or cable in center of sleeve. Assemble mechanical sleeve seals and install in annular space between raceway or cable and sleeve. Tighten bolts against pressure plates that cause sealing elements to expand and make watertight seal.

### **3.03 SLEEVE-SEAL-FITTING INSTALLATION**

- A. Install sleeve-seal fittings in new walls and slabs as they are constructed.
- B. Assemble fitting components of length to be flush with both surfaces of concrete slabs and walls. Position waterstop flange to be centered in concrete slab or wall.
- C. Secure nailing flanges to concrete forms.
- D. Using grout, seal the space around outside of sleeve-seal fittings.

**END OF SECTION 26 05 44**

## SECTION 26 05 53 – IDENTIFICATION FOR ELECTRICAL SYSTEMS

### PART 1 – GENERAL

#### 1.01 SUMMARY

- A. Section Includes:
1. Identification for raceways.
  2. Identification of power and control cables.
  3. Identification for conductors.
  4. Underground-line warning tape.
  5. Warning labels and signs.
  6. Instruction signs.
  7. Equipment identification labels.
  8. Miscellaneous identification products.

#### 1.02 RELATED SECTIONS

- A. Technical Specifications Sections in Division 26 – Electrical.

#### 1.03 SUBMITTALS

- A. Submittal procedures must be in accordance with the applicable provisions of:
1. **Section 6.6 Contract Data Requirements**
  2. **Section 7.41 Product Options, Supplier Approval and Substitutions**
  3. **Section 7.43 Submittal of Shop Drawings, Product Data and Samples**
  4. **Section 7.49.1 Certificate of Compliance**
  5. **Appendix B Contract Data Requirements**
- B. Product Data: For each electrical identification product indicated.
- C. Samples: For each type of label and sign to illustrate size, colors, lettering style, mounting provisions, and graphic features of identification products.
- D. Schedules:
1. Schedule for nameplates and tape labels.
  2. Panelboard Schedules: Typed as-built schedules.

#### 1.04 QUALITY ASSURANCE

- A. Comply with ANSI A13.1 and IEEE C2.
- B. Comply with NFPA 70.
- C. Comply with 29 CFR 1910.144 and 29 CFR 1910.145.

- D. Comply with ANSI Z535.4 for safety signs and labels.
- E. Adhesive-attached labeling materials, including label stocks, laminating adhesives, and inks used by label printers, shall comply with UL 969.

#### **1.05 COORDINATION**

- A. Coordinate identification names, abbreviations, colors, and other features with requirements in other Sections requiring identification applications, Contract Drawings, shop drawings, manufacturer's wiring diagrams, and the operation and maintenance manual; and with those required by codes, standards, and 29 CFR 1910.145. Use consistent designations throughout Project.
- B. Coordinate installation of identifying devices with completion of covering and painting of surfaces where devices are to be applied.
- C. Coordinate installation of identifying devices with location of access panels and doors.
- D. Install identifying devices before installing acoustical ceilings and similar concealment.

### **PART 2 – PRODUCTS**

#### **2.01 POWER AND CONTROL CABLE IDENTIFICATION MATERIALS**

- A. Cloth markers: Split sleeve or tubing type, with machine-printed identification.
- B. Vinyl Labels: Preprinted, flexible label laminated with a clear, weather- and chemical-resistant coating and matching wraparound clear adhesive tape for securing ends of legend label.
- C. Self-Adhesive, Self-Laminating Polyester Labels: Preprinted or Write-on, 3-mil (0.08 mm) thick flexible label with acrylic pressure-sensitive adhesive that provides a clear, weather- and chemical-resistant, self-laminating, protective shield over the legend. Labels sized to fit the cable diameter such that the clear shield overlaps the entire printed legend.
- D. Heat-Shrink Preprinted Tubes: Flame-retardant polyolefin tube with machine-printed identification label. Sized to suit diameter of and shrinks to fit firmly around cable it identifies. Full shrink recovery at a maximum of 200 deg. F. Comply with UL 224.
- E. Metal Tags: Brass or aluminum, 2 by 2 by 0.05 inch, with stamped legend, punched for use with self-locking cable tie fastener.
- F. Polyester Tags: 0.010 inch thick, with corrosion-resistant grommet and cable tie for attachment to conductor or cable.

Marker for Tags: Machine-printed, permanent, waterproof, black ink marker recommended by printer manufacturer.

#### **2.02 CONDUCTOR IDENTIFICATION MATERIALS**

- A. Color-Coding Conductor Tape: Colored, self-adhesive vinyl-tape not less than 3 mils (0.08 mm) thick by 1 to 2 inches (25 to 50 mm) wide.
- B. Cloth markers: Split sleeve or tubing type, with machine-printed identification.

- C. Self-Adhesive, Self-Laminating Polyester Labels: Preprinted, 3-mil- (0.08-mm-) thick flexible label with acrylic pressure-sensitive adhesive that provides a clear, weather- and chemical-resistant, self-laminating, protective shield over the legend. Labels sized to fit the conductor diameter such that the clear shield overlaps the entire printed legend.
- D. Heat-Shrink Preprinted Tubes: Flame-retardant polyolefin tube with machine-printed identification label. Sized to suit diameter of and shrinks to fit firmly around conductor it identifies. Full shrink recovery at a maximum of 200 deg F (93 deg C). Comply with UL 224.
- E. Marker Tapes: Vinyl or vinyl-cloth, self-adhesive wraparound type, with circuit identification legend machine printed by thermal transfer or equivalent process.

### **2.03 FLOOR MARKING TAPE, FOR MARKING EQUIPMENT CLEARANCE ZONES**

- A. 2-inch (50-mm) wide, 5-mil (0.125-mm) thick pressure-sensitive vinyl tape, with black and white or yellow and black stripes and clear vinyl overlay.

### **2.04 UNDERGROUND-LINE WARNING TAPE**

- A. Warning Tape:
  - 1. Comply with ANSI Z535.1 through ANSI Z535.5.
  - 2. Detectable warning tape, six-inch wide, 4-mil thick film, of inert material such as polyethylene plastic, with detectable foil backing; impervious to acids, alkalies, and other soil components; and supplied in continuous roll.
  - 3. Recommended by manufacturer for the method of installation and suitable to identify and locate underground electrical utility lines.
  - 4. Printing on tape shall be permanent and shall not be damaged by burial operations.
  - 5. Manufacturers:
    - a. TEK Identification Products
    - b. Thomas & Betts
    - c. Or approved equal.
  - 6. Color/Message: Bright red, electrically-detectable, film, with message in permanent bold letters, one-inch minimum height, one side only. The following message to be repeated continuously the full length of the tape:

For 600V and below: "CAUTION ELECTRIC LINE BELOW"

### **2.05 WARNING LABELS AND SIGNS**

Comply with NFPA 70 and 29 CFR 1910.145.

- A. Self-Adhesive Warning Labels: Factory-printed, multicolor, pressure-sensitive adhesive labels, configured for display on front cover, door, or other access to equipment unless otherwise indicated.

- B. Baked-Enamel Warning Signs:
  - 1. Preprinted aluminum signs, punched or drilled for fasteners, with colors, legend, and size required for application.
  - 2. 1/4-inch grommets in corners for mounting.
  - 3. Nominal size, 7 by 10 inches.
- C. Metal-Backed, Butyrate Warning Signs:
  - 1. Weather-resistant, nonfading, preprinted, cellulose-acetate butyrate signs with 0.0396-inch (1-mm) galvanized-steel backing; and with colors, legend, and size required for application.
  - 2. 1/4-inch grommets in corners for mounting.
  - 3. Nominal size, 10 by 14 inches.
- D. Warning label and sign shall include, but are not limited to, the following legends:
  - 1. Multiple Power Source Warning: "DANGER - ELECTRICAL SHOCK HAZARD - EQUIPMENT HAS MULTIPLE POWER SOURCES."
  - 2. Workspace Clearance Warning: "WARNING - OSHA REGULATION - AREA IN FRONT OF ELECTRICAL EQUIPMENT MUST BE KEPT CLEAR FOR 36 INCHES (915 MM)."

## **2.06 INSTRUCTION SIGNS**

- A. Engraved, laminated acrylic or melamine plastic, minimum 1/16 inch thick for signs up to 20 sq. inches and 1/8 inch thick for larger sizes.
  - 1. Engraved legend with black letters on white face.
  - 2. Punched or drilled for mechanical fasteners.
  - 3. Framed with mitered acrylic molding and arranged for attachment at applicable equipment.
- B. Adhesive Film Label: Machine printed, in black, by thermal transfer or equivalent process. Minimum letter height shall be 3/8 inch.
- C. Adhesive Film Label with Clear Protective Overlay: Machine printed, in black, by thermal transfer or equivalent process. Minimum letter height shall be 3/8 inch. Overlay shall provide a weatherproof and UV-resistant seal for label.

## **2.07 EQUIPMENT IDENTIFICATION LABELS**

- A. Adhesive Film Label: Machine printed, in black, by thermal transfer or equivalent process. Minimum letter height shall be 3/8 inch.
- B. Adhesive Film Label with Clear Protective Overlay: Machine printed, in black, by thermal transfer or equivalent process. Minimum letter height shall be 3/8 inch. Overlay shall provide a weatherproof and UV-resistant seal for label.
- C. Self-Adhesive, Engraved, Laminated Acrylic or Melamine Label: Adhesive backed, with white letters on a dark-gray background. Minimum letter height shall be 3/8 inch.



- D. Embossed Tape Labels: 1/2-inch wide adhesive tape, with 1/4 inch high black letters embossed on yellow background.
- E. Engraved Nameplates:
  - 1. Engraved two-layer (three layers if double-sided) laminated plastic; refer to "Engraving Schedule" in Part 3 for nameplate and lettering sizes. At Contractor's option, provide flexible self-adhesive thermal transfer type labels; Brady "LabelLite" or approved equal. Colors shall be as follows:
    - a. Typical:
      - 1) Yellow letters on a black background.
      - 2) Buildings 113, 115, 117, and 439: Black letters on silver background
    - b. Receptacles and Outlets: White letters on a black background.
    - c. Emergency Power Equipment and Receptacles: Black letters on a yellow background.
    - d. Distribution Panels Providing Emergency Power Source Entry: White letters on a blue background.
- F. Stenciled Legend: In nonfading, waterproof, black ink or paint. Minimum letter height shall be 1 inch.

## **2.08 MISCELLANEOUS IDENTIFICATION PRODUCTS**

- A. Fasteners for Labels and Signs: Self-tapping, stainless-steel screws or stainless-steel machine screws with nuts and flat and lock washers.

## **PART 3 – EXECUTION**

### **3.01 INSTALLATION**

- A. Verify identity of each item before installing identification products.
- B. Location: Install identification materials and devices at locations for most convenient viewing without interference with operation and maintenance of equipment.
- C. Apply identification devices to surfaces that require finish after completing finish work.
- D. Preparation: Degrease and clean surfaces to receive nameplates and tape labels.
- E. Self-Adhesive Identification Products: Clean surfaces before application using materials and methods recommended by manufacturer of identification device.
- F. Attach signs and plastic labels that are not self-adhesive type with mechanical fasteners appropriate to the location and substrate.
- G. Install nameplates and tape labels parallel to equipment lines.
- H. Location:
  - 1. Equipment: Adhere nameplates to equipment fronts.
  - 2. Conductors: Provide wire markers on each conductor in panelboard gutters, pull boxes, outlet and junction boxes, and at load connection.

- I. Tape labels will not be permitted for any application.
- J. Use tape labels only for identification of individual wall switches and receptacles and control device stations.
- K. Aluminum Wraparound Marker Labels and Metal Tags: Secure tight to surface of conductor or cable at a location with high visibility and accessibility.
- L. Cable Ties: For attaching tags use general-purpose type, except as listed below:
  - 1. Outdoors: UV-stabilized nylon.
  - 2. In Spaces Handling Environmental Air: Plenum rated.
- M. Underground-Line Warning Tape:
  - 1. Bury warning tape above all concrete-encased ducts and ductbanks.
  - 2. In unpaved areas, bury the tape in the trench 12 inches below the surface.
  - 3. In paved areas, install the tape in the trench just below the pavement section.
  - 4. Align tape parallel to and within 3 inches (75 mm) of the centerline of ductbank. Extend to underground structure and building exterior walls.
  - 5. Provide an additional warning tape for each 12-inch increment of ductbank width over a nominal 18 inches. Space additional tapes 12 inches apart, horizontally.
  - 6. Take all necessary precautions to ensure that the warning tape is not pulled, distorted, or otherwise misplaced during backfilling.
  - 7. In joint trenches, do not omit detectible warning tape for underground electrical and communications conduits. Coordinate installation location of detectible warning tape with required warning tapes for gas and heating hot water piping.
  - 8. Refer to Technical Specifications Section 23 11 26 – Facility Liquefied-Petroleum Gas Piping for additional information.

### **3.02 EQUIPMENT IDENTIFICATION SCHEDULE**

- A. Electrical Equipment, Typical: Identify all drives, starters, disconnect switches, and control devices, with nameplate. Identification shall exactly match equipment nameplate legend noted on the Contract Drawings, or approved shop drawings. Nameplate Size: 1 inch high with 1/2-inch high letters.

### **3.03 CONDUCTOR IDENTIFICATION SCHEDULE**

- A. Power and Lighting Circuits: Identify branch-circuit or feeder number with wire markers.
- B. Control Circuits: Identify control wire number as indicated on schematic and interconnection diagrams or equipment manufacturer's shop drawings, with wire markers.

### **3.04 RACEWAY IDENTIFICATION SCHEDULE**

- A. Accessible Raceways and Metal-Clad Cables, 600 V or Less, for Service, Feeder, and Branch Circuits More Than 30 A, and 120 V to ground: Identify with self-adhesive vinyl label or self-adhesive vinyl tape applied in bands. Install labels at 10-foot Accessible Raceways and Cables

within Buildings: Identify the covers of each junction and pull box of the following systems with self-adhesive vinyl labels with the wiring system legend and system voltage. System legends shall be as follows:

1. Emergency Power.
  2. Power.
- B. Power-Circuit Conductor Identification, 600 V or Less: For conductors in vaults, pull and junction boxes, manholes, and handholes, use color-coding conductor tape to identify the phase.
1. Color-Coding for Phase and Voltage Level Identification, 600 V or Less: Use colors listed below for ungrounded feeder conductors.
    - a. Color shall be factory applied or field applied for sizes larger than No. 12 AWG, if authorities having jurisdiction permit.
    - b. Colors for 208/120-V Circuits:
      - 1) Phase A: Black.
      - 2) Phase B: Red.
      - 3) Phase C: Blue.
    - c. Field-Applied, Color-Coding Conductor Tape: Apply in half-lapped turns for a minimum distance of 6 inches from terminal points and in boxes where splices or taps are made. Apply last two turns of tape with no tension to prevent possible unwinding. Locate bands to avoid obscuring factory cable markings.
- C. Install instructional sign including the color code for grounded and ungrounded conductors using adhesive-film-type labels.
- D. Control-Circuit Conductor Identification: For conductors and cables in pull and junction boxes, manholes, and handholes, use self-adhesive, self-laminating polyester labels with the conductor or cable designation, origin, and destination.
- E. Control-Circuit Conductor Termination Identification: For identification at terminations provide self-adhesive, self-laminating polyester labels with the conductor designation.
- F. Conductors to Be Extended in the Future: Attach write-on tags to conductors and list source.
- G. Auxiliary Electrical Systems Conductor Identification: Identify field-installed alarm, control, and signal connections.
  1. Identify conductors, cables, and terminals in enclosures and at junctions, terminals, and pull points. Identify by system and circuit designation.
  2. Use system of marker tape designations that is uniform and consistent with system used by manufacturer.
- H. Locations of Underground Lines: Identify with underground-line warning tape for power, lighting, communication, and control wiring and optical fiber cable.

1. Install underground-line warning tape for both direct-buried cables and cables in raceway.
- I. Workspace Indication: Install floor marking tape to show working clearances in the direction of access to live parts. Workspace shall be as required by NFPA 70 and 29 CFR 1926.403 unless otherwise indicated. Do not install at flush-mounted panelboards and similar equipment in finished spaces.
- J. Warning Labels for Indoor Cabinets, Boxes, and Enclosures for Power and Lighting: Self-adhesive warning labels or Baked-enamel warning signs or Metal-backed, butyrate warning signs.
  1. Comply with 29 CFR 1910.145.
  2. Identify system voltage with black letters on an orange background.
  3. Apply to exterior of door, cover, or other access.
  4. For equipment with multiple power or control sources, apply to door or cover of equipment including, but not limited to, the following:
    - a. Controls with external control power connections.
- K. Operating Instruction Signs: Install instruction signs to facilitate proper operation and maintenance of electrical systems and items to which they connect. Install instruction signs with approved legend where instructions are needed for system or equipment operation.
- L. Emergency Operating Instruction Signs: Install instruction signs with white legend on a red background with minimum 3/8-inch-high letters for emergency instructions at equipment used for power transfer or load shedding.

**END OF SECTION 26 05 53**

**DIVISION 31 – EARTHWORK**  
**SECTION 31 10 00 – SITE CLEARING**

**PART 1 – GENERAL**

**1.01 SECTION INCLUDES**

- A. Removing existing vegetation.
- B. Clearing and grubbing.
- C. Removing above and below grade site improvements.
- D. Disconnecting, capping or sealing, and removing or abandoning site utilities in place.

**1.02 RELATED SECTIONS**

- A. Technical Specifications **Section 02 32 19 – Potholing**
- B. Technical Specifications **Section 02 41 19 – Selective Demolition**

**1.03 MATERIALS OWNERSHIP**

- A. Except for materials indicated to be stockpiled or otherwise remain VTA property, cleared materials become Contractor's property and must be removed from Worksite in an appropriate and legal manner.

**1.04 SAFETY REQUIREMENTS**

- A. General: Maintain neat, orderly, and hazard-free on-site operations until final acceptance of the Work in conformance with CAL OSHA requirements.

**1.05 PROJECT CONDITIONS**

- A. Minimize interference with adjoining driveways, walks, and other adjacent occupied or used facilities during site-clearing operations.
- B. Do not close or obstruct walks and driveways or other occupied or used facilities without written permission from VTA.
- C. Provide alternate routes around closed or obstructed driveways if required by VTA.
- D. Potholing: Perform potholing before commencing site clearing. Refer to Technical Specifications **Section 02 32 19 – Potholing**.

**PART 2 – PRODUCTS (NOT USED)**

**PART 3 – EXECUTION**

**3.01 PREPARATION**

- A. Protect and maintain benchmarks and survey control points from disturbance during construction.
- B. Protect existing site improvements to remain from damage during construction.  
Restore damaged improvements to remain from damage during construction.

C. Temporary Facilities:

Provide temporary barricades, warning signs, lights, delineators, shields, and other provisions necessary to protect passerby from injury or discomfort around the demolition area.

**3.02 TEMPORARY EROSION AND SEDIMENTATION CONTROL**

- A. Provide temporary erosion and sedimentation control measure to prevent soil erosion and discharge of soil-bearing water runoff or airborne dust to adjacent areas. Refer to Appendix G Environmental Coordination and Cooperation.

**3.03 CLEARING AND GRUBBING**

- A. Remove obstructions, tree roots, and other vegetation as required for new construction.
- B. Fill and compact all voids caused by the removal of pipe, structures, etc., and clearing and grubbing operations with satisfactory fill material. Provide for positive drainage of the disturbed area to drain run-off in a direction consistent with the surrounding area. Provide all fill materials to the site as needed. Compaction of fill must match the compaction of adjacent undisturbed material.

**3.04 SITE IMPROVEMENTS**

- A. Remove existing above and below grade improvements as indicated and necessary to facilitate new construction.
1. Remove pavements, sidewalks, curbs and gutters and other existing features where necessitated by the installation of new utility trenches.
- B. Piped Utility Demolition
1. Disconnect, demolish, excavate and remove piped utility systems, equipment, and components indicated to be removed.
    - a. Removed Piping: Remove portion of piping indicated to be removed and cap or plug remaining piping with same or compatible piping material.
    - b. Abandoned in Place Piping: Drain piping. Fill abandoned piping with flowable fill, and cap or plug piping with same or compatible piping material.
    - c. Removed Equipment: Disconnect and cap services and equipment indicated to be removed.
- C. Provide additional site clearing as indicated in other Technical Specifications Sections and the Contract Drawings, and as required for new construction.

**3.05 DISPOSAL OF SURPLUS AND WASTE MATERIALS**

- A. Remove surplus soil material, unsuitable topsoil, obstructions, demolished materials, and waste materials including trash and debris, and legally dispose of them off VTA property.

**END OF SECTION 31 10 00**

## **SECTION 9 CONTRACT DRAWINGS / PLANS**

The Contract Drawings/Plans are provided in the following pages.

*[This Page Intentionally Left Blank]*



# SANTA CLARA VALLEY TRANSPORTATION AUTHORITY

## CERONE DIVISION

### BOILER AND PROPANE TANK REPLACEMENT

#### CONTRACT C19123

#### CONSTRUCTION DOCUMENTS

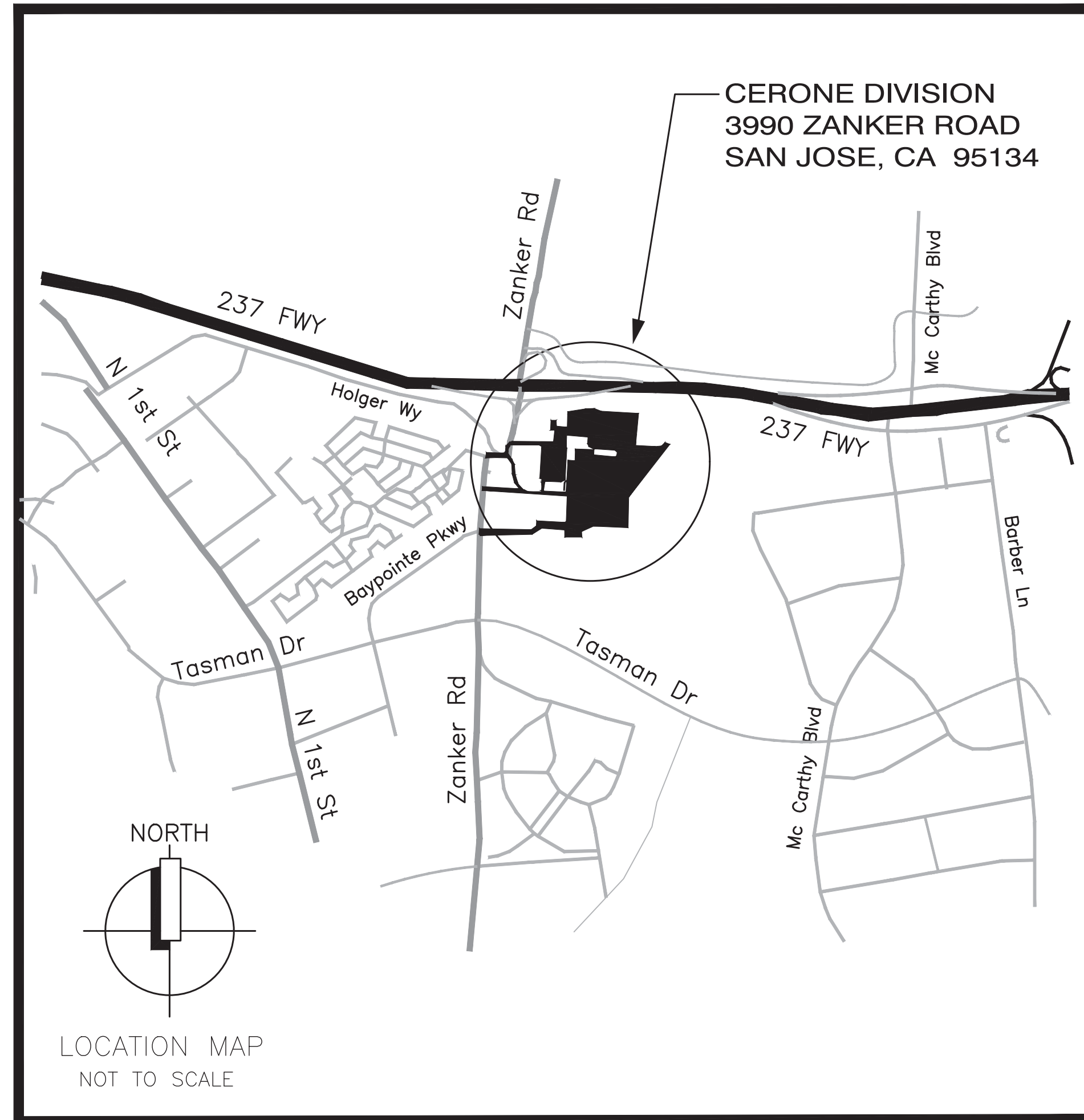

DRAWING INDEX		
DRAWING #	SHEET #	SHEET NAME
T1	1	TITLE SHEET
G1	2	GENERAL NOTES, STAGING & ACCESS PLAN
C1	3	CIVIL COMMON TRENCH OVERALL SITE PLAN
C2	4	CIVIL COMMON TRENCH SITE PLAN - 1
C3	5	CIVIL COMMON TRENCH SITE PLAN - 2
C4	6	CIVIL COMMON TRENCH SITE PLAN - 3
D1	7	DEMOLITION - BLDG. F
D2	8	DEMOLITION - BLDG. F - DETAILS
D3	9	DEMOLITION - PROPANE TANK / DETAILS
D4	10	DEMOLITION - BLDG. G / DETAILS
P1	11	PLUMBING - COVER SHEET
P2	12	PLUMBING - MATERIAL AND METHODS SCHEDULES
P3.1	13	PLUMBING - SCHEDULES
P3.2	14	PLUMBING - SCHEDULES
P3.3	15	PLUMBING - SCHEDULES
P4	16	PLUMBING - SITE PLAN - OVERALL
P5	17	PLUMBING - PROPANE SYSTEM PLAN - ENLARGED
P6	18	PLUMBING - PROPANE SYSTEM PLAN - ENLARGED
P7	19	PLUMBING - UNDERGROUND PROPANE PLAN
P8	20	PLUMBING - LIQUID & GASEOUS PROPANE STORAGE & DIST. SYSTEM - P&ID
P9	21	PLUMBING - PROPANE TANK DETAILS
P10	22	PLUMBING - BUILDING G - UTILITY ROUTING
P11	23	PLUMBING - BUILDING F - HEATING HOT WATER SYSTEM - P&ID DEMO
P12	24	PLUMBING - BUILDING F - HEATING HOT WATER SYSTEM - P&ID PROPOSED
P13	25	PLUMBING - BUILDING F - CENTRAL UTILITIES BUILDING - DEMO PLAN
P14	26	PLUMBING - BUILDING F - CENTRAL UTILITIES BUILDING - PROPOSED PLAN
P15	27	PLUMBING - BUILDING B & E - NEW HHW PIPING PLAN
P16	28	NOT USED
P17	29	PLUMBING - DETAILS

DRAWING #	SHEET #	SHEET NAME
P18	30	PLUMBING - DETAILS
P19	31	PLUMBING - DETAILS
P20	32	PLUMBING - DETAILS
P21	33	PLUMBING - DETAILS
S1	34	PARTIAL SITE PLAN
S2	35	STRUCTURAL DETAILS
E1	36	ELECTRICAL - SYMBOLS, ABBREV., INDEX AND NOTES
E2	37	ELECTRICAL - SINGLE LINE DIAGRAM
-	38	NOT USED
-	39	NOT USED
E3	40	ELECTRICAL - TITLE 24 POWER DIST. COMPLIANCE FORMS
E4	41	ELECTRICAL - SITE PLAN OVERALL
E5	42	NOT USED
E6	43	ELECTRICAL - PLAN AREA 2
E7	44	ELECTRICAL - PLAN AREA 3
E8	45	ELECTRICAL - PLAN AREA 4
-	46	NOT USED
E9	47	ELECTRICAL - PANEL SCHEDULES
E10	48	ELECTRICAL - DETAILS
-	49	NOT USED

### PROJECT DESCRIPTION

REPLACEMENT OF THE EXISTING LIQUID PROPANE SYSTEM AND MODIFICATIONS TO THE EXISTING CENTRALIZED HEATING HOT WATER SYSTEM.

1. NEW LIQUID PROPANE GAS STORAGE TANK, LIQUID PROPANE FUEL FILL STATION, LIQUID PROPANE GAS VAPORIZERS, AND LIQUID PROPANE GAS DISTRIBUTION PIPING (ABOVEGROUND AND BELOW GROUND).
2. DEMOLITION OF EXISTING LIQUID PROPANE GAS STORAGE TANK.
3. NEW ABOVEGROUND AND BELOWGROUND HEATING HOT WATER PIPING; CONNECT TO EXISTING SYSTEMS.
4. MODIFY EXISTING CENTRALIZED HEATING HOT WATER BOILER SYSTEM.
5. REMOVAL OF UNUSED EXPANSION TANKS AND RELATED SUPPORT STRUCTURES.

NO.	DATE	REVISIONS
1	06/01/20	ISSUE FOR BID



SUBMITTED		 Integrated Engineering Services 70 SARATOGA AVE. * SUITE 200 SANTA CLARA, CA. 95051-7301 PHONE: (408)261-3500 * FAX (408)261-4176 www.IESengineering.net	
DESIGNED	TR	CHECKED	LC
DRAWN	HL	CADD FILE NAME	



APPROVED	
CADD FILE DATE	SCALE
APRIL 15, 2020	NONE
PLOT DATE	BOARD APPROVAL DATE
-	-

CERONE DIVISION BOILER AND PROPANE TANK REPLACEMENT			SHEET 1 OF 49 DRAWING NO. T1 REVISION 1
TITLE SHEET			
SAP NO.	CONTRACT NO.	FILE LOCATION	
	C19123		



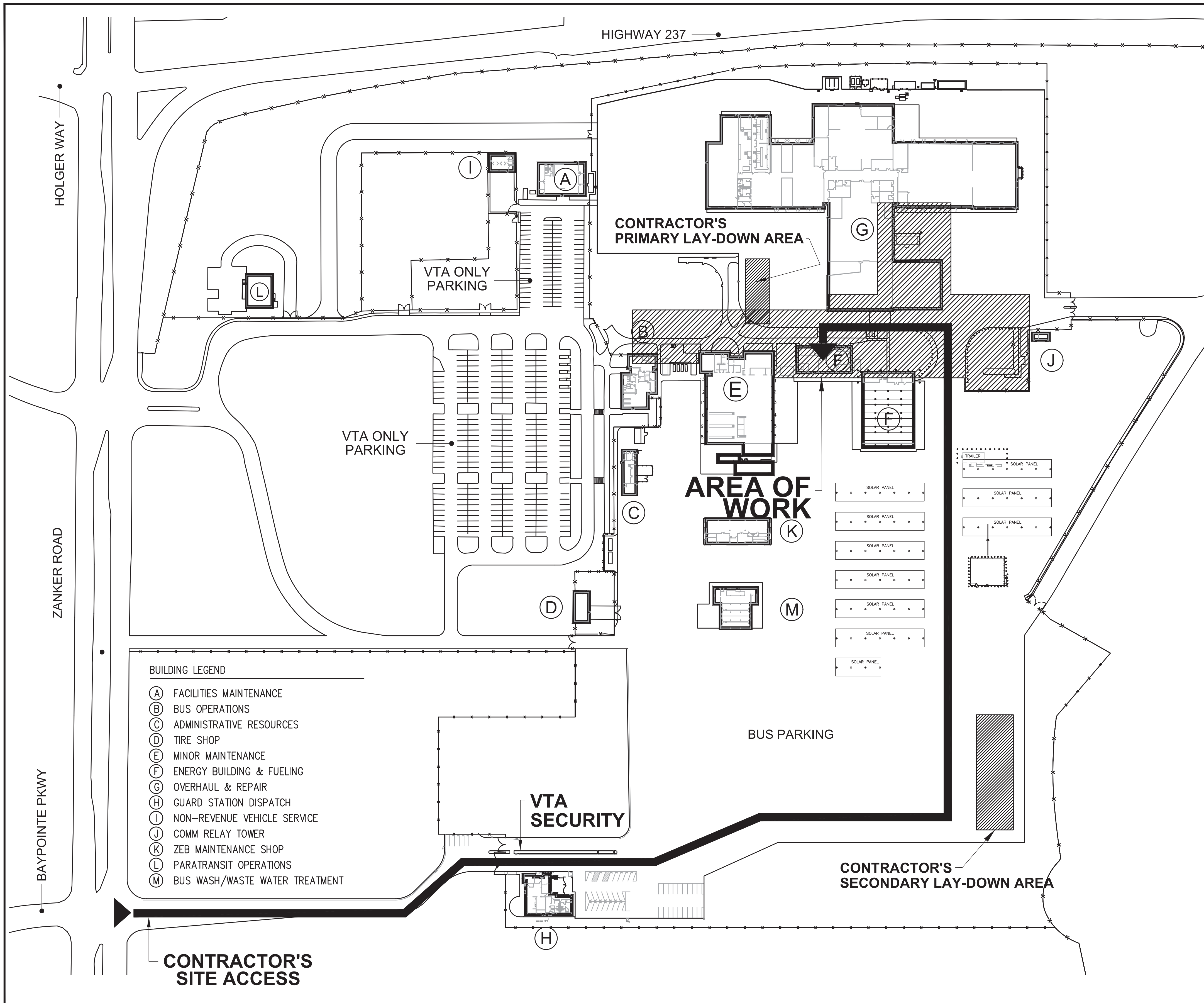

## GENERAL PROJECT NOTES

- CAREFULLY EXAMINE THE CONTRACT DOCUMENTS FOR COMPLETE SCOPE OF WORK.
- CONTRACTOR IS RESPONSIBLE FOR VISITING THE SITE AND SATISFYING THEMSELVES AS TO THE CONDITIONS UNDER WHICH THE WORK WILL BE PERFORMED. CONTRACTOR MUST CHECK ALL EXISTING INSTALLATIONS AND SYSTEM RELATED TO THEIR WORK, AND CHECK ALL EXISTING CONDITIONS WHICH MAY AFFECT THEIR WORK. NO ALLOWANCE WILL BE MADE FOR ANY EXTRA EXPENSE WHICH MAY BE INCURRED DUE TO NEGLIGENCE OR FAILURE TO EXAMINE THE SITE, EXISTING CONDITIONS, UTILITIES, ETC. THE SITE VISIT MUST BE DONE DURING THE BID WALK, OR PREARRANGED WITH VTA.
- CONTRACTOR MUST INCLUDE IN THEIR BID PROPOSAL ALL LABOR AND MATERIAL REQUIRED FOR PROPER COMPLETION OF FULLY FUNCTIONAL SYSTEMS. THE SUBMITTAL OF A BID PROPOSAL WILL BE CONSIDERED AS CONCLUSIVE EVIDENCE THAT THE CONTRACTOR IS THOROUGHLY FAMILIAR WITH THE INTENT OF THE CONTRACT DOCUMENTS.
- NO DEVIATION FROM THE CONTRACT DOCUMENTS MAY BE MADE WITHOUT PRIOR APPROVAL BY VTA.
- DO NOT SCALE THE DRAWINGS. DIMENSIONS TO BE GOVERNED BY ACTUAL CONDITIONS AT THE SITE. CONTRACTOR MUST FIELD VERIFY PRIOR TO COMMENCING CONSTRUCTION. ABSOLUTE ACCURACY OF THE DRAWINGS CANNOT BE GUARANTEED, WHILE EVERY EFFORT HAS BEEN MADE TO IDENTIFY THE LOCATION OF EXISTING UTILITIES, EQUIPMENT, PIPING, ETC., IT IS THE RESPONSIBILITY OF THE CONTRACTOR TO COORDINATE THE EXACT REQUIREMENTS AS GOVERNED BY THE ACTUAL FIELD CONDITIONS.
- WORK MUST CONFORM TO ALL LOCAL, STATE, AND FEDERAL REGULATIONS, CODES, AND ORDINANCES IN EFFECT. ALL SAFETY PROVISIONS MUST BE STRICTLY ADHERED TO IN EVERY DETAIL. CONTRACTOR MUST PROVIDE QUALIFIED TRADE PROFESSIONALS WITH ADEQUATE SAFETY TRAINING IN CONSTRUCTION OF THESE TYPES OF FACILITIES. ALL WORK MUST CONFORM TO THE 2016 CALIFORNIA MECHANICAL CODE, PLUMBING CODE, FIRE CODE, BUILDING CODE, ENERGY CODE, AND THE NATIONAL ELECTRICAL CODE.
- ALL MATERIALS AND WORKMANSHIP ARE SUBJECT TO APPROVAL BY VTA. ANY DEFECTIVE PORTION OF THE WORK MUST BE REPLACED BY THE CONTRACTOR AS PART OF THIS CONTRACT AT NO ADDITIONAL COST TO VTA.
- PROTECT ALL EXISTING STRUCTURES, UTILITIES, EQUIPMENT, ETC. MAINTAIN ALL ACTIVE UTILITIES, LINES, SERVICES, EQUIPMENT, ETC. IN GOOD OPERATING CONDITION.
- PROTECT EXISTING BUILDING STRUCTURES AND ADJACENT FINISHED SURFACES DURING CONSTRUCTION. PATCH REPAIR, AND REFINISH EXISTING CONSTRUCTION DAMAGED BY CONTRACTOR'S WORK TO MATCH ADJACENT UNDISTURBED AREAS. PATCHING, REPAIRING, AND REFINISHING SHALL BE PERFORMED BY WORKMEN SKILLED IN THE TRADES INVOLVED.
- CONTRACTOR MUST COORDINATE TRADES TO OPTIMIZE INSTALLATION. ANY DEFICIENCIES IN SYSTEM DESIGN OR PERFORMANCE AS A RESULT OF INADEQUATE COORDINATION BETWEEN TRADES SHALL BE REMEDIED TO THE SATISFACTION OF VTA, AT NO ADDITIONAL COST TO VTA.
- CONTRACTOR MUST SCHEDULE AND COORDINATE THE FOLLOWING WITH VTA
  - ANY AND ALL UTILITY SHUTDOWNS. CONTRACTOR MUST REQUEST EACH UTILITY SHUTDOWN OR SERVICE INTERRUPTION A MINIMUM OF 3 WEEKS IN ADVANCE.
  - ANY AND ALL WORK BEING PERFORMED IN AREAS WHERE REGULAR VTA OPERATIONS AND MAINTENANCE ACTIVITIES ARE PERFORMED.
  - ANY NIGHT, WEEKEND, OR NON-STANDARD WORK SHIFTS.
- CONTRACTOR USE OF PREMISES:  
COMPLY WITH SPECIAL CONDITIONS SECTION 6.11 "WORK SEQUENCE AND CONSTRAINTS." CONSTRUCTION WILL BE PERFORMED ON A SITE WITH ONGOING 24 HOURS A DAY BUS MAINTENANCE AND OPERATIONS ACTIVITY. COORDINATE, PHASE, SCHEDULE, AND PERFORM WORK IN SUCH A MANNER THAT ONGOING VTA ACTIVITIES CONTINUE WITHOUT DISRUPTION.
- TEMPORARY CONTROLS:  
CONTRACTOR MUST PROVIDE AND MAINTAIN PROPER BARRICADES, DUST CONTROL, LIGHTING, AND ANY OTHER TEMPORARY DEVICES NECESSARY FOR THE PROTECTION OF LIFE AND PROPERTY, AND TO PRESERVE THE NORMAL LEVEL OF ONGOING BUS MAINTENANCE OPERATIONS.
- CONTRACTOR MUST PRESERVE ACCESS FOR EXISTING ONGOING VTA SITE OPERATIONS, INCLUDING (BUT NOT LIMITED TO):
  - MAINTAINING ACCESS FOR TANKER TRUCKS TO THE DIESEL FILL PORT AT ALL TIMES.
  - MAINTAINING PROPER OPERATION OF THE EXISTING PROPANE SYSTEM TO SUPPLY EXISTING END USE DEVICES WITH FULL SERVICE, UNTIL VTA HAS APPROVED CUTOVER OF ALL (OR DISCRETE PORTIONS OF) THE PROPANE SYSTEM TO THE NEW INFRASTRUCTURE. THIS SHALL INCLUDE PRESERVING ACCESS TO THE PROPANE FILL PORT FOR TANKER TRUCKS AS REQUIRED FOR REFILLS.
  - SHUTDOWNS OF SERVICE (PROPANE, ELECTRICAL, COMMUNICATIONS, ETC.), TEMPORARY OR OTHERWISE, MUST BE APPROVED IN WRITING BY VTA IN ADVANCE.
- SITE ACCESS AND EGRESS:  
AS INDICATED ON THIS SHEET, CONTRACTOR MUST USE THE ENTRANCE GATE AT VTA SECURITY AS THE MAIN VEHICULAR AND PEDESTRIAN ACCESS TO THE SITE.
- PARKING:  
CONTRACTOR MUST PROVIDE PARKING FACILITIES FOR CONTRACTOR PERSONNEL AND SUBCONTRACTORS. CONTRACTOR AND SUBCONTRACTOR ARE PROHIBITED FROM PARKING PERSONAL VEHICLES AT CERONE DIVISION, INCLUDING AREAS INDICATED ON THIS DRAWING AS VTA EMPLOYEE PARKING LOTS.
- IDENTIFIED AUTHORITIES HAVING JURISDICTION (AHJ'S):
  - VTA
  - SANTA CLARA COUNTY DEPARTMENT OF ENVIRONMENTAL HEALTH - HAZARDOUS MATERIALS COMPLIANCE DIVISION (HMCD). HMCD IS THE CERTIFIED UNIFIED PROGRAM AGENCY (CUPA) FOR THIS PROJECT.
  - BAY AREA AIR QUALITY MANAGEMENT DISTRICT (BAAQMD).
  - CALIFORNIA DEPARTMENT OF OCCUPATIONAL SAFETY AND HEALTH (DOSH).
- HAZMAT / ENVIRONMENTAL REGULATORY CLEARANCES:  
COMPLY WITH SPECIAL CONDITIONS SECTION 6.7 "PERMITS, FEES AND INSPECTIONS". CONTRACTOR MUST PROVIDE TO THE AUTHORITIES HAVING JURISDICTION (AHJ'S) ALL INFORMATION NECESSARY FOR HAZMAT / ENVIRONMENTAL PERMITS, CLEARANCES AND AUTHORIZATIONS NECESSARY FOR THIS PROJECT. CONTRACTOR MUST COMPLY WITH ALL AHJ PROVISIONS, INCLUDING GIVING NOTICES FOR INSPECTIONS DURING CONSTRUCTION WHEN SO REQUIRED.
- CONTRACTOR MUST COORDINATE FINAL INSPECTION OF COMPLETED WORK WITH VTA AND VTA'S DESIGN REPRESENTATIVE(S), FOR FINAL APPROVAL AND ACCEPTANCE.

NO.	DATE	REVISIONS
1	06/01/20	ISSUE FOR BID



SUBMITTED		 Integrated Engineering Services 70 SARATOGA AVE. * SUITE 200 SANTA CLARA, CA. 95051-7301 PHONE: (408)261-3500 * FAX (408)261-4176 www.IESengineering.net	
DESIGNED	TR	CHECKED	LC
DRAWN	HL	CADD FILE NAME	-



APPROVED	
CADD FILE DATE	SCALE
APRIL 15, 2020	1" = 100'
PLOT DATE	BOARD APPROVAL DATE
-	-

CERONE DIVISION BOILER AND PROPANE TANK REPLACEMENT			SHEET 2 OF 49
GENERAL NOTES, STAGING AND ACCESS PLAN			DRAWING NO. G1
SAP NO.	CONTRACT NO. C19123	FILE LOCATION	REVISION 1



# ABBREVIATIONS

- AC. or A.C. = Asphalt Concrete
- C. & G. = Curb and Gutter
- C.B. = Catch Basin
- C.T. = Common Trench
- Conc. = Concrete
- Ex. or Exist. = Existing
- GPR. = Ground Penetrating Radar
- Inv. = Invert
- L.F. = Linear Feet
- N.T.S. = Not To Scale
- Pav. = Pavement
- S/W = Sidewalk
- TYP. = Typical
- O.G. = Original Ground

# CIVIL GENERAL NOTES:

1. TOPOGRAPHIC BASE MAP REPRESENTS SURFACE FEATURES ONLY.
2. EX. UNDERGROUND UTILITIES SHOWN REPRESENTS BEST AVAILABLE INFORMATION, HOWEVER CONTRACTOR SHALL FIELD VERIFY AND POT HOLE AS NECESSARY TO POSITIVELY IDENTIFY UTILITY LOCATIONS.
3. LIGHT, THIN LINES REPRESENT EXISTING CONDITIONS.
4. HEAVY, THICK LINES REPRESENT NEW WORK.
5. PROVIDE SHORING (PER OSHA) AT TRENCHES EXCEEDING 5' DEEP, AND AS REQUIRED BY VTA.
6. SAWCUT ALL EX. AC & PCC PAVEMENTS. SAWCUT AT EX. SCORE LINES.
7. RESTORE ALL SURFACES TO PRIOR CONDITION OR BETTER.
8. PROVIDE APPROPRIATE TRENCH PROTECTION AND TEMPORARY WALKWAY PROVISIONS WHERE TRENCH CROSSES PEDESTRIAN PATHWAY. PROVIDE TRAFFIC PLATING AND APPROPRIATE TRENCH PROTECTION MEASURES WHERE NECESSARY TO FACILITATE VEHICULAR OPERATIONS, AND AS REQUIRED BY VTA.
9. REFER TO PLUMBING AND ELECTRICAL DRAWINGS FOR EXACT PIPE/CONDUIT SIZE REQUIRED AT EACH TRENCH SECTION.

# LEGEND

- |     |                               |           |                         |            |                          |     |                 |
|-----|-------------------------------|-----------|-------------------------|------------|--------------------------|-----|-----------------|
| --- | EX. BUILDING LINE             | BFP       | BACK FLOW PREVENTER     | HB         | HOSE BIBB                | STL | STREET LIGHTING |
| --- | NEW COMMON TRENCH             | BLDC      | BUILDING CORNER         | IRR        | IRRIGATION CONTROL VALVE | W   | WATER           |
| --- | EX. CURB LINE                 | BLDL      | BUILDING LINE           | MISC-MH    | MISCELLANEOUS MANHOLE    | WLT | WATER VAULT     |
| --- | EX. FENCE LINE                | BOL       | BOLLARD                 | M-WELL, MW | MONITORING WELL          | WM  | WATER METER     |
| --- | EX. GAS LINE                  | BOL/LIGHT | BOLLARD LIGHT           | SDCO       | STORM DRAIN CLEANOUT     | WPB | WATER PULLBOX   |
| --- | EX. COMMUNICATION LINE        | CNTNR     | CONTAINER               | SDMH       | STORM DRAIN MANHOLE      | WV  | WATER VALVE     |
| --- | EX. UNDERGROUND ELECTRIC LINE | COMM      | COMMUNICATION           | SSCO       | SANITARY CLEANOUT        |     |                 |
| --- | EX. WATER LINE                | COMM-MH   | COMMUNICATION MANHOLE   | SSMH       | SANITARY MANHOLE         |     |                 |
| --- | EX. SANITARY SEWER LINE       | COMM-PB   | COMMUNICATION PULLBOX   | STPB       | STREET LIGHT PULLBOX     |     |                 |
| --- | EX. STORM DRAIN LINE          | CONC      | CONCRETE                | SW, S/W    | SIDEWALK                 |     |                 |
| --- | EX. UNKNOWN UTILITY LINE      | EG        | EXISTING GROUND         | TC         | TOP OF CURB              |     |                 |
| --- | EX. SPOT ELEVATION            | ELEC      | ELECTRIC                | COMM       | COMMUNICATION            |     |                 |
| --- | EX. ASPHALT AREA              | ELEC-MH   | ELECTRICAL MANHOLE      | ELEC       | ELECTRICAL               |     |                 |
| --- | EX. CONCRETE AREA             | EP        | EDGE OF PAVEMENT        | GAS        | GAS                      |     |                 |
| --- | NEW CONCRETE AREA             | EPB       | ELECTRICAL PULLBOX      | SD         | STORM DRAIN              |     |                 |
| --- | NEW TRENCH SEGMENT ID         | FF        | BUILDING FINISHED FLOOR | SS         | SANITARY SEWER           |     |                 |
| --- |                               | FH        | FIRE HYDRANT            |            |                          |     |                 |
| --- |                               | FNC       | FENCE                   |            |                          |     |                 |
| --- |                               | GM        | GAS METER               |            |                          |     |                 |
| --- |                               | GV        | GAS VALVE               |            |                          |     |                 |

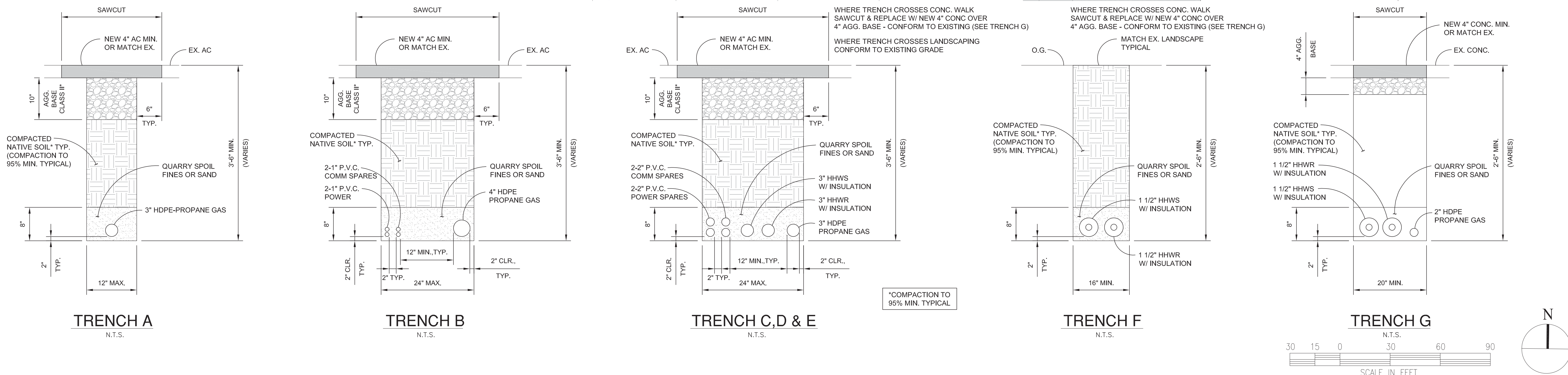
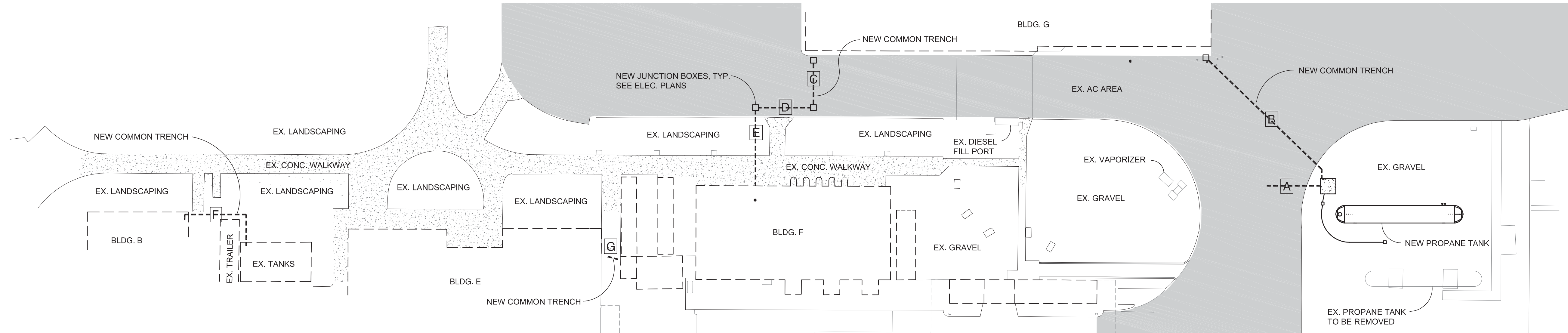

NO.	DATE	REVISIONS
1	06/02/20	ISSUED FOR BID

**PEOPLES ASSOCIATES**  
 STRUCTURAL ENGINEERS  
 1150 Campbell Ave • San Jose, CA 95126  
 408-957-9220 www.pase.com

DESIGNED	VS	CHECKED	RHO
DRAWN	RSC	CADD FILE NAME	18-094

**Santa Clara Valley Transportation Authority**

APPROVED	
CADD FILE DATE	SCALE
06/02/19	1"=30'-0"
PLOT DATE	BOARD APPROVAL DATE
06/02/19	-

<b>CERONE DIVISION</b> <b>BOILER AND PROPANE TANK REPLACEMENT</b> <b>CIVIL COMMON TRENCH OVERALL SITE PLAN</b>		
SAP NO.	CONTRACT NO.	FILE LOCATION
	C19123	
SHEET <b>3</b> OF 49 DRAWING NO. <b>C1</b>		REVISION <b>1</b>



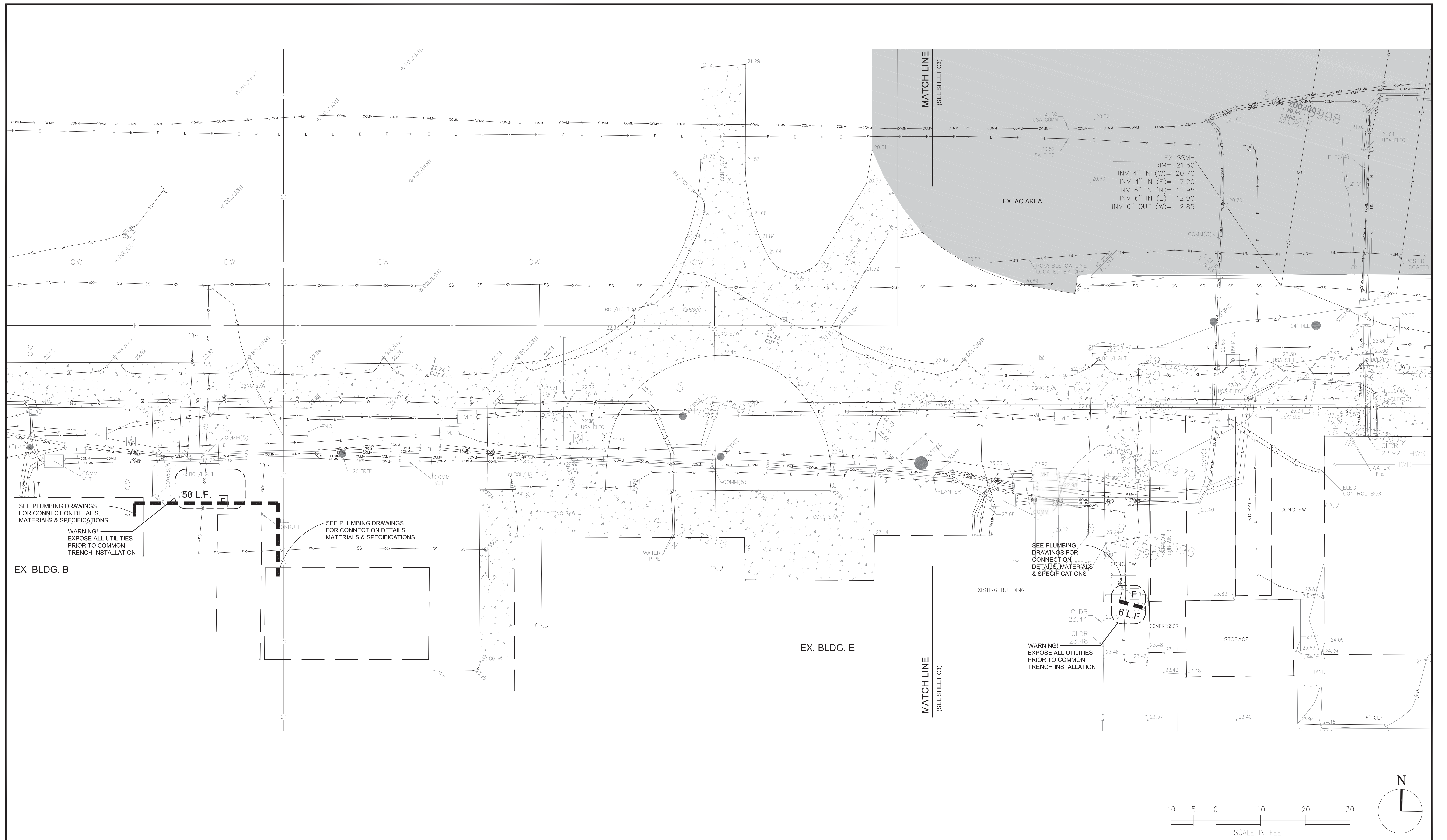

NO.	DATE	REVISIONS
1	06/02/20	ISSUED FOR BID

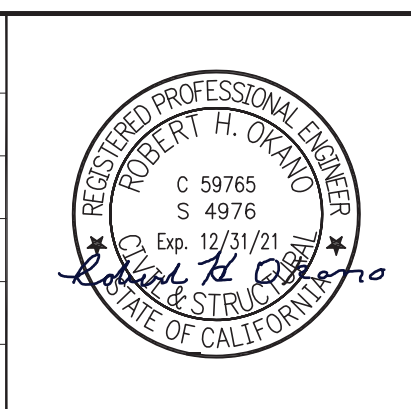

SUBMITTED

**PEOPLES ASSOCIATES**  
STRUCTURAL ENGINEERS  
1150 Campbell Ave • San Jose, CA 95126  
408-957-9220 www.pase.com

DESIGNED VS CHECKED RHO  
DRAWN RSC CADD FILE NAME 18-094

**VTA** Santa Clara Valley  
Transportation  
Authority

APPROVED

CADD FILE DATE	SCALE
06/02/19	1"=10'-0"
PLOT DATE	BOARD APPROVAL DATE
06/02/19	-

**CERONE DIVISION**  
**BOILER AND PROPANE TANK**  
**REPLACEMENT**  
**CIVIL COMMON TRENCH**  
**SITE PLAN - 1**

SAP NO. CONTRACT NO. C19123 FILE LOCATION

SHEET 4 OF 49 DRAWING NO. C2 REVISION 1











**LEGEND:**

----- DEMOLITION LINE

**KEYED NOTES:**

- ① REMOVE (E) PIPE. AT CONDITIONED SPACES, INFILL WALL PENETRATIONS WITH INSULATION MATERIAL TO MATCH (E).
- ② REMOVE PIPE TO BELOW TOP OF (E) SLAB. SEAL PIPE WITH NON-SHRINK GROUT. REPAIR THE (E) SLAB WITH REPAIR MORTAR. FINISH FLUSH WITH SURROUNDING GRADE.
- ③ PROVIDE 16 GA. GALVANIZED SHEET METAL OVER WALL OPENINGS, MIN. 2" OVERLAP. PROVIDE SUITABLE BACKING MATERIAL AND FASTENING AS REQUIRED. APPLY SEALANT TO ALL EDGES. FINISH AND PAINT TO MATCH ADJACENT SURFACE.
- ④ PATCH DRYWALL PENETRATIONS. PROVIDE SUITABLE BACKING MATERIAL AND FASTENING AS REQUIRED. FINISH AND PAINT TO MATCH ADJACENT SURFACE.
- ⑤ REPLACE DAMAGED FLOOR DRAIN GRATE, MATCH (E)

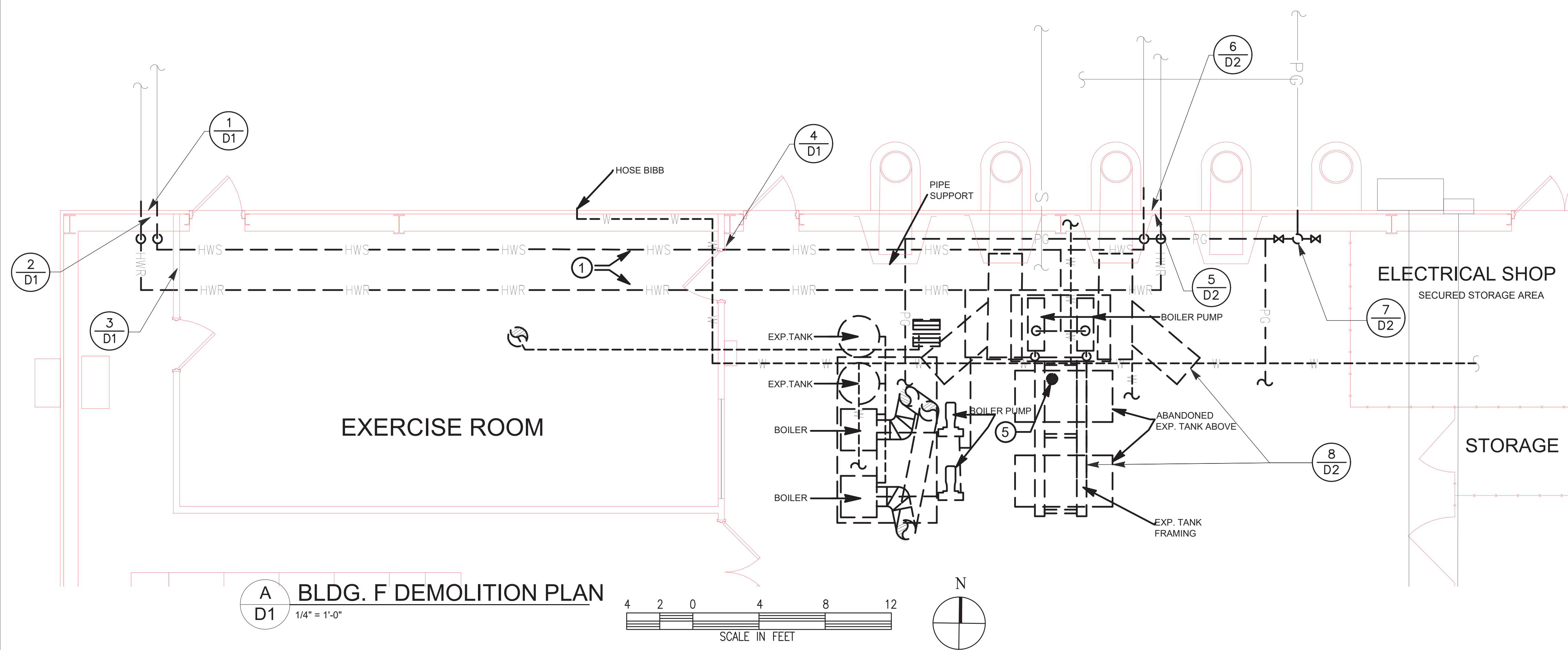

**A**  
**D1** BLDG. F DEMOLITION PLAN  
1/4" = 1'-0"

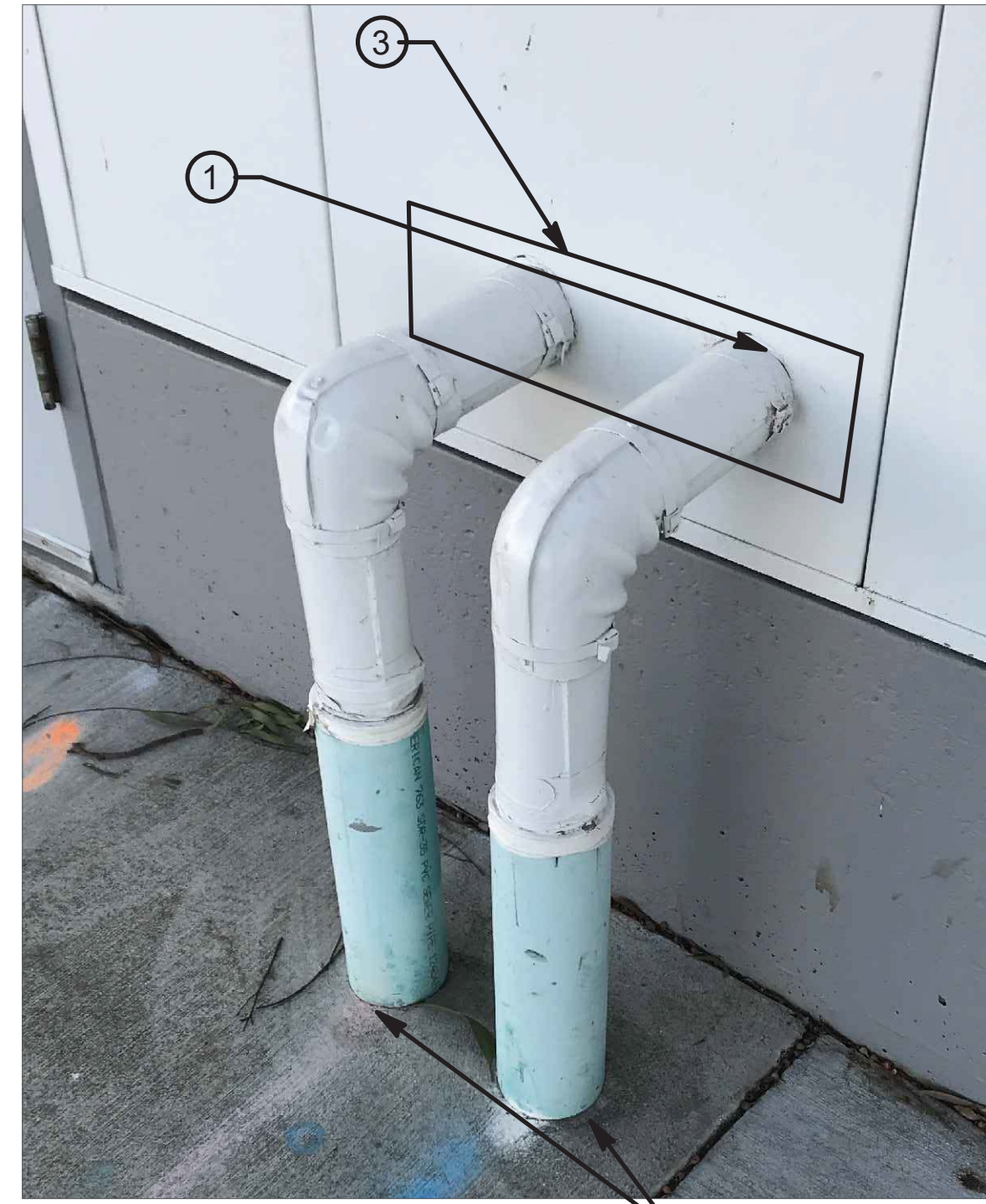
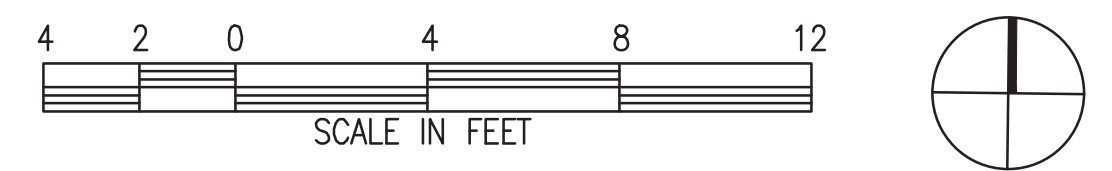

**1**  
**D1** HWS/HWR OUTSIDE PENETRATION  
NTS



**2**  
**D1** HWS/HWR INSIDE PENETRATION  
NTS



**3**  
**D1** HWS/HWR EXIT EXERCISE ROOM  
NTS



**4**  
**D1** HWS/HWR INTO EXERCISE ROOM  
NTS

NO.	DATE	REVISIONS
1	10/1/20	ISSUED FOR BID



SUBMITTED	
DESIGNED	CHECKED
KS/MGD	JO
DRAWN	CADD FILE NAME
KS	



APPROVED	
CADD FILE DATE	SCALE
	1/4" = 1'-0"
PLOT DATE	BOARD APPROVAL DATE
06/12/2020	

CERONE DIVISION BOILER AND PROPANE TANK REPLACEMENT DEMOLITION - BLDG F / DETAILS			SHEET OF 49 DRAWING NO. D1 REVISION
SAP NO.	CONTRACT NO. C19123	FILE LOCATION	





5 LPG PIPING - INSIDE PENETRATION  
D2 NTS

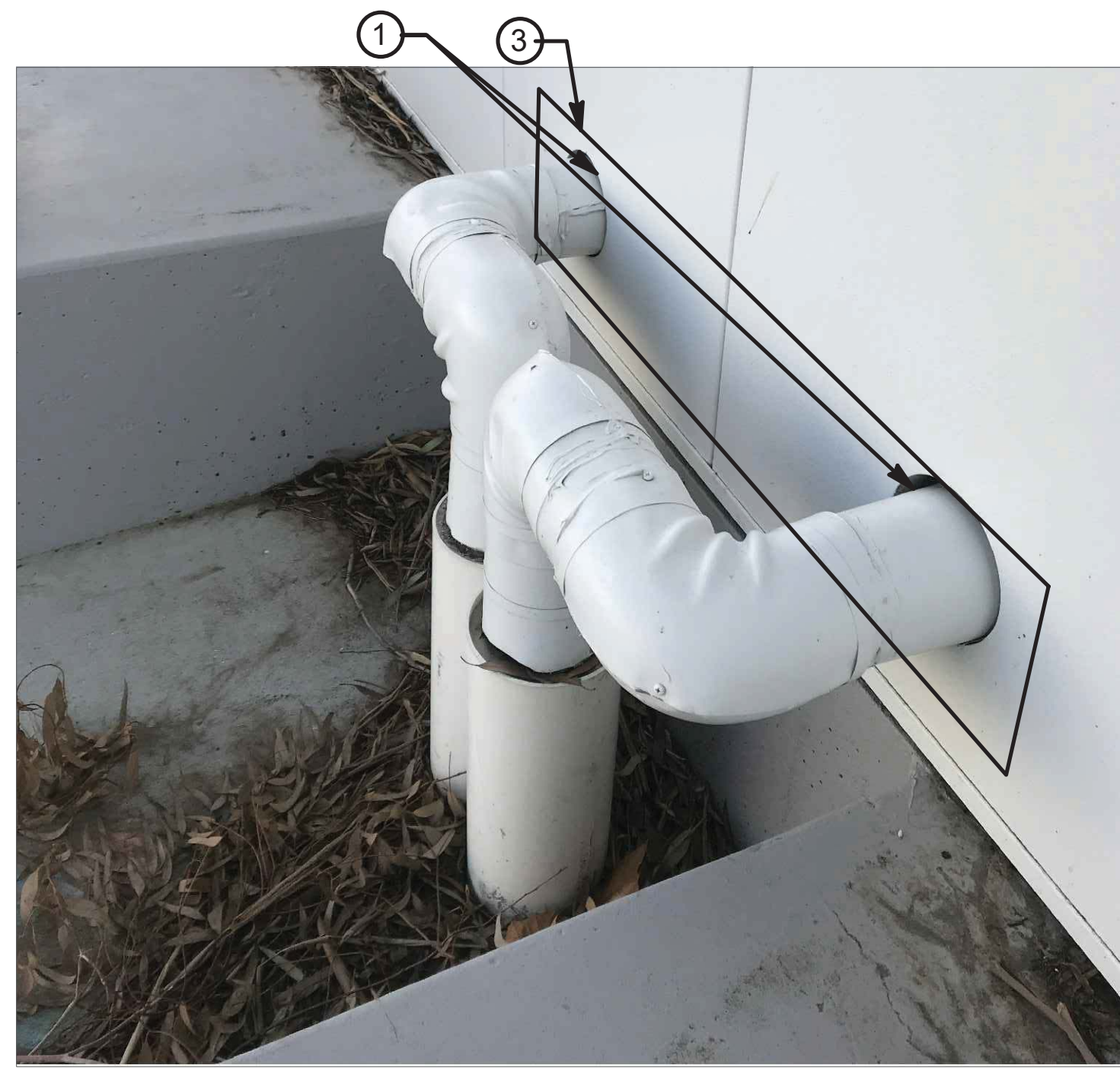

6 LPG PIPING - OUTSIDE PENETRATION  
D2 NTS



7 LPG VALVE AND PIPING  
D2 NTS

**KEYED NOTES:**

- ① REMOVE (E) PIPE. AT CONDITIONED SPACES, INFILL WALL PENETRATIONS WITH INSULATION MATERIAL TO MATCH (E).
- ② REMOVE PIPE TO BELOW TOP OF (E) SLAB. SEAL PIPE WITH NON-SHRINK GROUT. REPAIR THE (E) SLAB WITH REPAIR MORTAR. FINISH FLUSH WITH SURROUNDING GRADE.
- ③ PROVIDE 16 GA. GALVANIZED SHEET METAL OVER WALL OPENINGS, MIN. 2" OVERLAP. PROVIDE SUITABLE BACKING MATERIAL AND FASTENING AS REQUIRED. APPLY SEALANT TO ALL EDGES. FINISH AND PAINT TO MATCH ADJACENT SURFACE.
- ④ REMOVE ALL (E) LPG LINES AND ITS APPURTENANCES.
- ⑤ REMOVE (E) TRUSS SUPPORT, ABANDONED EXPANSION TANKS, AND ALL RELATED PIPING.
- ⑥ REMOVE (E) CAPPED FLUE STACK UP TO PIPE SUPPORT. PROVIDE CAP/SEAL FOR REMAINING PIPE.
- ⑦ PROTECT IN PLACE EXISTING PLUMBING TO REMAIN.

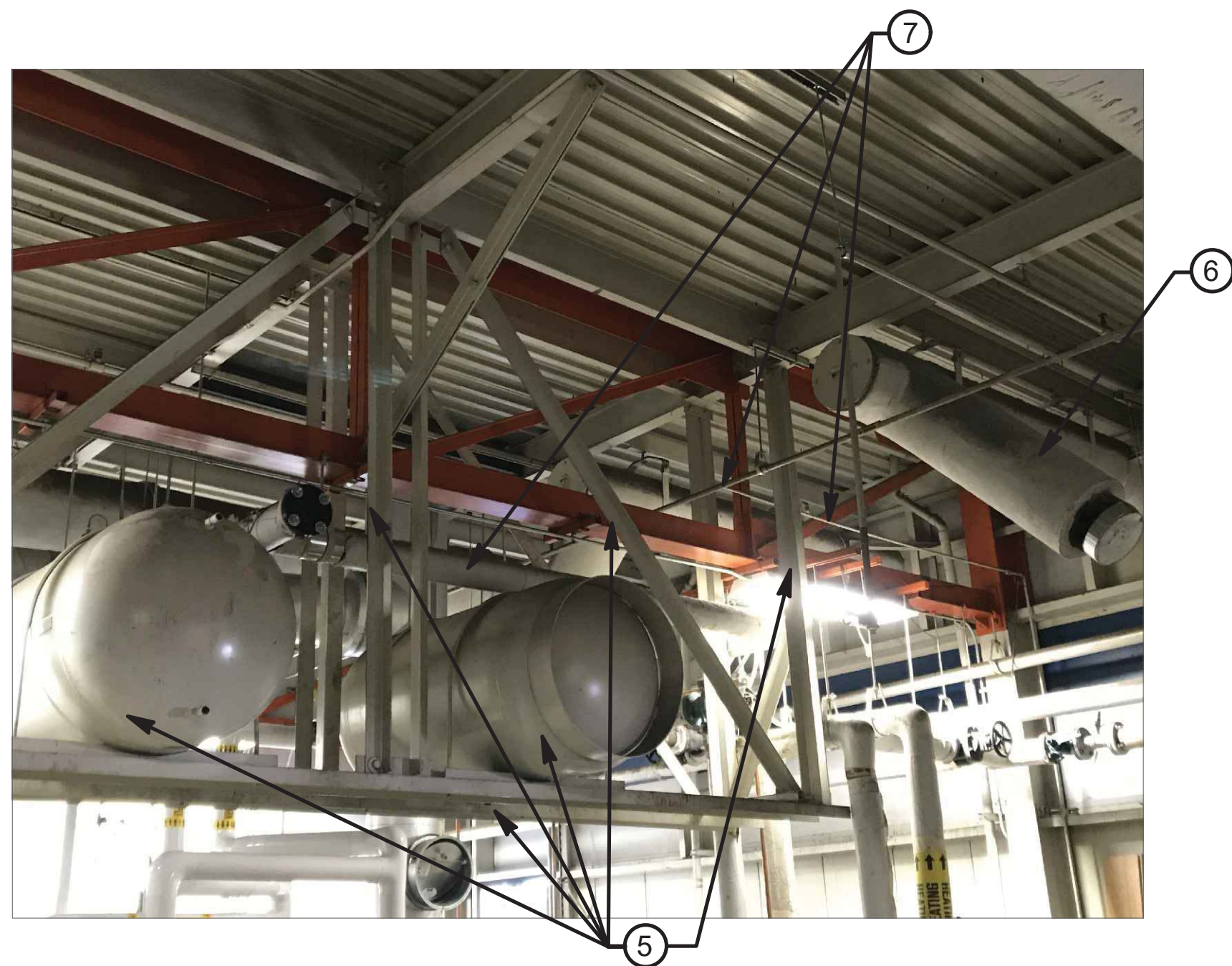

8 TRUSS SUPPORT AND EXPANSION TANKS  
D2 NTS

NO.	DATE	REVISIONS
1	10/1/20	ISSUED FOR BID



SUBMITTED	
DESIGNED	CHECKED
KS/MGD	JO
DRAWN	CADD FILE NAME
KS	



APPROVED	
CADD FILE DATE	SCALE
	NTS
PLOT DATE	BOARD APPROVAL DATE
06/12/2020	

CERONE DIVISION BOILER AND PROPANE TANK REPLACEMENT DEMOLITION - BLDG F DETAILS			SHEET OF 49 DRAWING NO. D2 REVISION
SAP NO.	CONTRACT NO. C19123	FILE LOCATION	



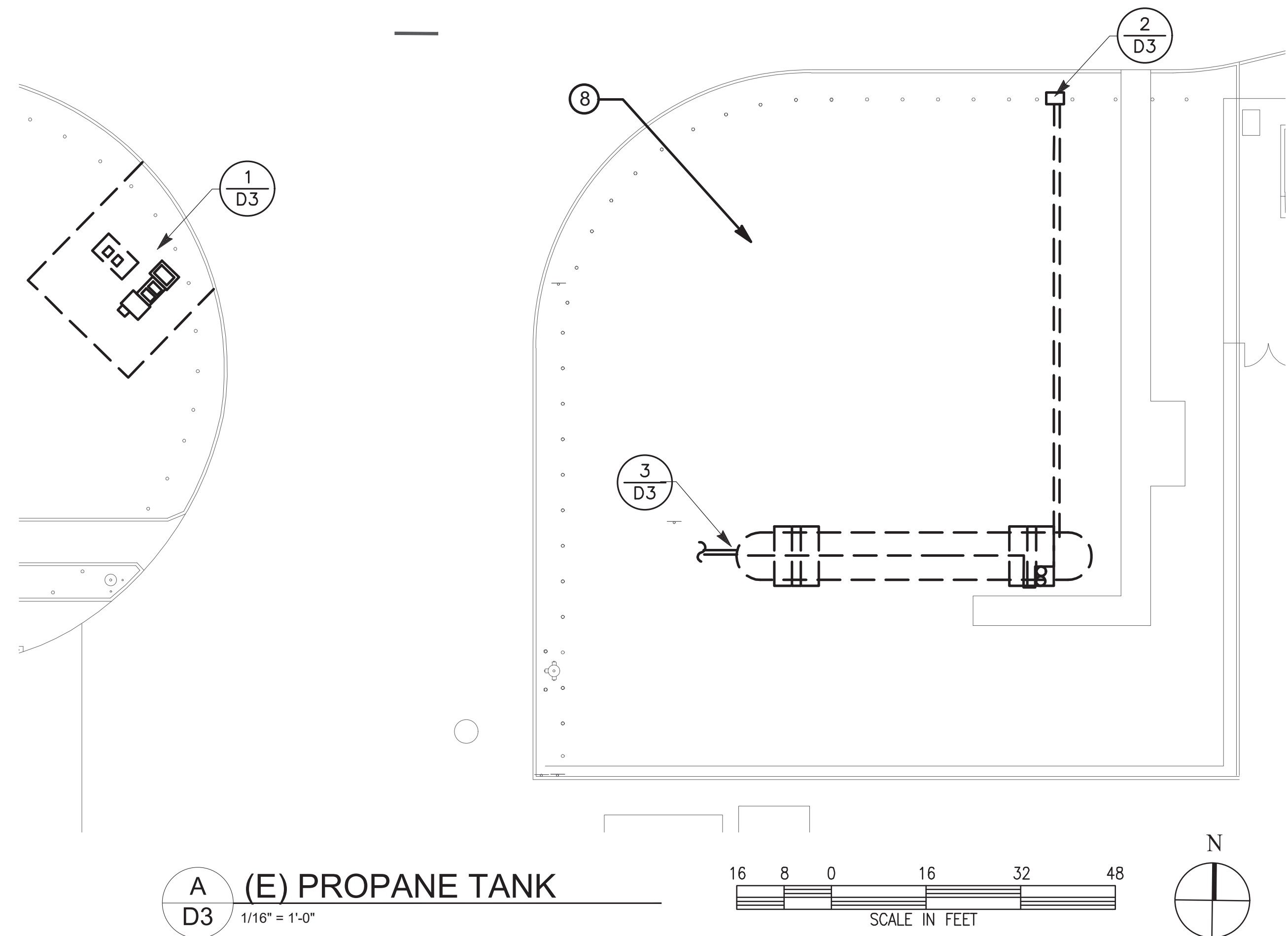

**A (E) PROPANE TANK**  
D3 1/16" = 1'-0"

**LEGEND:**

----- DEMOLITION LINE

**KEYED NOTES:**

- ① REMOVE (E) CHAIN LINK FENCE. CUT OFF FENCE POSTS AT GRADE.
- ② REMOVE (E) LPG VAPORIZERS AND ASSOCIATED PIPING. HOUSEKEEPING PADS AND UTILITY PULL BOXES TO REMAIN.
- ③ REMOVE (E) FILLPORT AND CONCRETE BULKHEAD, INCLUDING FOUNDATION. NOTE: FOUNDATION IS 39" DEEP WITH REBAR REINFORCEMENT. BACKFILL WITH GRAVEL.
- ④ REMOVE ALL (E) ABOVEGROUND PIPING AND PIPE SUPPORTS.
- ⑤ REMOVE THE (E) LPG TANK AND ALL ASSOCIATED PIPING AND COMPONENTS IN ITS ENTIRETY.
- ⑥ REMOVE (E) CONCRETE SADDLES INCLUDING FOUNDATION. NOTE: FOUNDATION IS 18" DEEP WITH REBAR REINFORCEMENT.
- ⑦ REMOVE PIPE AND CONDUITS TO TOP OF (E) GRADE. PLACE A CAP/SEAL ON PIPE STUB OUTS.
- ⑧ CLEAR AND GRUB ALL VEGETATION FROM ENTIRE FIELD AREA AROUND PROPANE TANK.



**1 LPG VAPORIZERS**  
D3 NTS



**2 LPG FILLPORT**  
D3 NTS



**3 30,000 GALLON LPG TANK**  
D3 NTS

NO.	DATE	REVISIONS
1	10/1/20	ISSUED FOR BID



SUBMITTED	
DESIGNED	CHECKED
KS/MGD	JO
DRAWN	CADD FILE NAME
KS	



APPROVED	
CADD FILE DATE	SCALE
	1/16" = 1'-0"
PLOT DATE	BOARD APPROVAL DATE
11/26/2019	

<b>CERONE DIVISION BOILER AND PROPANE TANK REPLACEMENT DEMOLITION - PROPANE TANK / DETAILS</b>			SHEET <b>9</b> OF 49 DRAWING NO. <b>D3</b> REVISION 1
SAP NO.	CONTRACT NO.	FILE LOCATION	
	C19123		



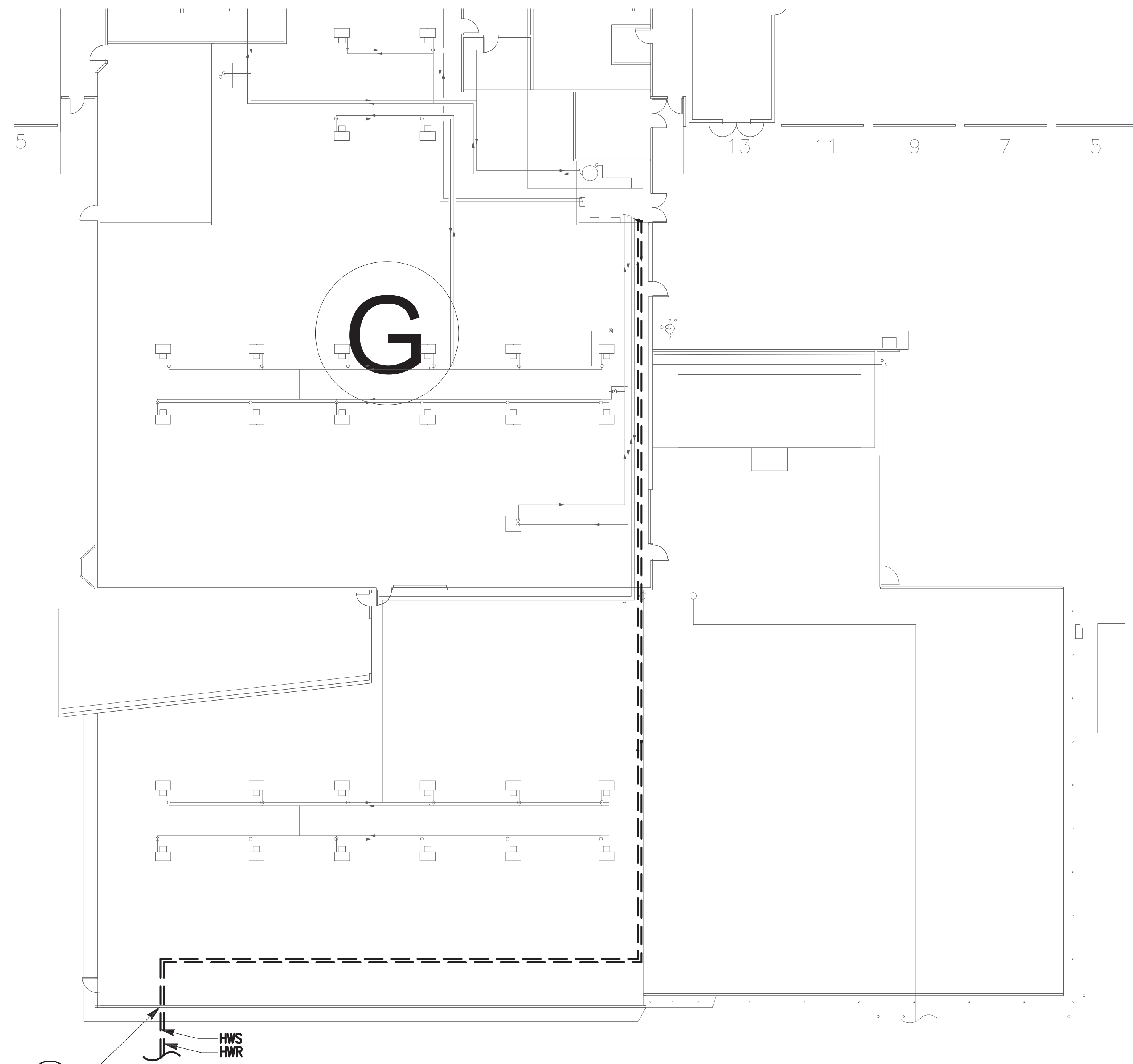

**LEGEND:**

----- EXISTING HHW LINE

**KEYED NOTES:**

- ① CUT AND CAP EXISTING HHW PIPES AT GRADE.
- ② REMOVE UNUSED PORTION OF PIPING BETWEEN NEW POINT OF CONNECTION AND STUB UP.
- ③ CONNECT NEW HHW PIPING TO EXISTING HHW PIPING AT APPROXIMATELY THIS LOCATION. SEE PLUMBING DRAWINGS.



① HWS/HWR OUTSIDE PENETRATION  
D4 NTS

① ② ③ ①  
D4  
A BLDG. G DEMOLITION PLAN  
1/16" = 1'-0"

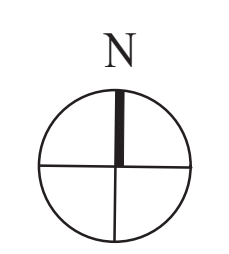
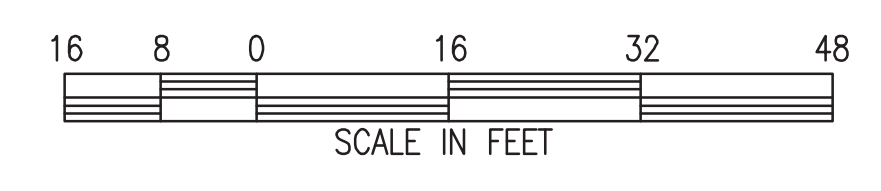

NO.	DATE	REVISIONS
1	10/1/20	ISSUED FOR BID



SUBMITTED	
DESIGNED KS/MGD	CHECKED JO
DRAWN KS	CADD FILE NAME



APPROVED	
CADD FILE DATE	SCALE 1/16" = 1'-0"
PLOT DATE 06/12/2020	BOARD APPROVAL DATE

CERONE DIVISION BOILER AND PROPANE TANK REPLACEMENT DEMOLITION - BLDG G / DETAILS			SHEET OF 49 DRAWING NO. D4 REVISION 1
SAP NO.	CONTRACT NO. C19123	FILE LOCATION	



ABBREVIATIONS		PIPING SYMBOLS		REFERENCE SYMBOLS		PLUMBING GENERAL NOTES		SITE MAP	
ABBREV	DESCRIPTION	SYMBOL	ABBREV	DESCRIPTION	SYMBOL	DESCRIPTION			
AFG	ABOVE FINISHED GRADE		RPBFP	REDUCED PRESSURE BACKFLOW PREVENTER 2-1/2" & LARGER		DETAIL 1 SHEET P8.1			
AG	ABOVE GROUND		RPBFP	REDUCED PRESSURE BACKFLOW PREVENTER 2" & SMALLER		SECTION 1 SHEET P5.1			
APR	AUTOMATIC PRESSURE RELIEF		BV	BALL VALVE		EQUIPMENT MARK NO. P-1			
AS	AUTOMATIC SPRINKLER		BV	BALANCE VALVE		PROCESS TOOL #			
ASJ	INSULATION MATERIAL		BFV	BUTTERFLY VALVE		REVISION #			
AWWS	ALTERNATIVE WATER SUPPLY			CHECK VALVE BALL TYPE		KEYED NOTE #			
BTU, BTUH	BRITISH THERMAL UNIT PER HOUR			CHECK VALVE - SWING TYPE		POINT OF CONNECTION TO EXISTING (POC)			
BLR	BOILER			CHECK VALVE - SWING TYPE		EXISTING TO BE REMOVED (DEMOLISHED)			
BMS	BUILDING MANAGEMENT SYSTEM		CS	CIRCUIT SETTER		EXISTING TO REMAIN			
CC/SEC	COOLING COIL (SECONDARY)		GV	GATE VALVE		NEW			
CMU	CONCRETE MASONRY UNIT (WALL)		PV	PLUG VALVE					
COND	CONDENSATE		GLV	GLOBE VALVE					
C.S.	CARBON STEEL		NV	NEEDLE VALVE					
DCW	DOMESTIC COLD WATER (CITY WATER)		DV	DIAPHRAGM VALVE					
DHW	DOMESTIC HOT WATER		MAV	MANUAL AIR VENT					
DI	DEIONIZED WATER		AAV	AUTOMATIC AIR VENT					
DWG	DRAWING		TDV	TRIPLE DUTY VALVE					
DWV	DRAIN WASTE VENT			TRIPLE DUTY VALVE					
EPDM	ETHYLENE PROPYLENE DIENE MONOMER (RUBBER)			TRIPLE DUTY VALVE					
EA	EACH			TRIPLE DUTY VALVE					
EOL	END OF LINE			TRIPLE DUTY VALVE					
ET	EXTENSION			TRIPLE DUTY VALVE					
FD	FLOOR DRAIN			TRIPLE DUTY VALVE					
FM	FLOW METER			TRIPLE DUTY VALVE					
FS	FLOW SWITCH OR FLOOR SINK			TRIPLE DUTY VALVE					
GPM	GALLONS PER MINUTE			TRIPLE DUTY VALVE					
GV	GLOBE VALVE			TRIPLE DUTY VALVE					
HDPE	HIGH DENSITY POLYETHYLENE			TRIPLE DUTY VALVE					
HHW	HEATING HOT WATER			TRIPLE DUTY VALVE					
HHWR	HEATING HOT WATER RETURN			TRIPLE DUTY VALVE					
HHWS	HEATING HOT WATER SUPPLY			TRIPLE DUTY VALVE					
HORIZ	HORIZONTAL			TRIPLE DUTY VALVE					
HPP	HIGH PRESSURE PROPANE			TRIPLE DUTY VALVE					
HS	HIGH SPEED (COMMUNICATION)			TRIPLE DUTY VALVE					
HWS	HOT WATER SUPPLY			TRIPLE DUTY VALVE					
HOA	HAND-OFF-AUTOMATIC SWITCH			TRIPLE DUTY VALVE					
HW	HOT WATER			TRIPLE DUTY VALVE					
HWR	HOT WATER RETURN			TRIPLE DUTY VALVE					
ICW	INDUSTRIAL COLD WATER			TRIPLE DUTY VALVE					
IPS	INTERNATIONAL PIPE STANDARD			TRIPLE DUTY VALVE					
LP	LIQUID PROPANE			TRIPLE DUTY VALVE					
LPG	LIQUEFIED PROPANE GAS			TRIPLE DUTY VALVE					
MBSH	THOUSAND BTU'S PER HOUR			TRIPLE DUTY VALVE					
MDPE	MEDIUM DENSITY POLYETHYLENE			TRIPLE DUTY VALVE					
MFR OR MFR'D	MANUFACTURER			TRIPLE DUTY VALVE					
N2	NITROGEN			TRIPLE DUTY VALVE					
(N)	NEW			TRIPLE DUTY VALVE					
NC	NORMALLY CLOSED			TRIPLE DUTY VALVE					
NG	NATURAL GAS			TRIPLE DUTY VALVE					
OC	ON CENTER			TRIPLE DUTY VALVE					
OS&Y	OUTSIDE STEM & YOKE			TRIPLE DUTY VALVE					
P	PROPANE			TRIPLE DUTY VALVE					
PDIT	PRESSURE DIFFERENTIAL TRANSDUCER			TRIPLE DUTY VALVE					
PFG/ASJ	PERFLUORO GUANIDINE			TRIPLE DUTY VALVE					
PG	PRESSURE GAUGE OR PROPANE GAS			TRIPLE DUTY VALVE					
PI	PRESSURE INDICATOR			TRIPLE DUTY VALVE					
PIT	PRESSURE INDICATOR/TRANSMITTER			TRIPLE DUTY VALVE					
PMP	PUMP			TRIPLE DUTY VALVE					
PP	PETE'S PLUG			TRIPLE DUTY VALVE					
PSIG	GAUGE PRESSURE (PSI)			TRIPLE DUTY VALVE					
P-VAPOR	PROPANE VAPOR			TRIPLE DUTY VALVE					
PVC	POLYVINYL CHLORIDE			TRIPLE DUTY VALVE					
R	REAUMUR (TEMP. UNIT)			TRIPLE DUTY VALVE					
RET	RETURN			TRIPLE DUTY VALVE					
RPBP	REDUCED PRESSURE BACK FLOW PREVENTER			TRIPLE DUTY VALVE					
S	SUPPLY			TRIPLE DUTY VALVE					
SCHED OR SCH	SCHEDULE			TRIPLE DUTY VALVE					
SD	SUCTION DIFFUSER			TRIPLE DUTY VALVE					
SS	STAINLESS STEEL OR SANITARY SEWER			TRIPLE DUTY VALVE					
STD	STANDARD			TRIPLE DUTY VALVE					
SUPP	SUPPLY			TRIPLE DUTY VALVE					
TDV	TRIPLE DUTY VALVE			TRIPLE DUTY VALVE					
TE	TEMPERATURE			TRIPLE DUTY VALVE					
TG	TEMPERATURE GAUGE			TRIPLE DUTY VALVE					
THK	THICK (NESS)			TRIPLE DUTY VALVE					
TI	TEMPERATURE INDICATOR			TRIPLE DUTY VALVE					
TIT	TEMPERATURE INDICATOR/TRANSMITTER			TRIPLE DUTY VALVE					
TYP	TYPICAL			TRIPLE DUTY VALVE					
UON OR U.N.O.	UNLESS OTHERWISE NOTED			TRIPLE DUTY VALVE					
V	VENT			TRIPLE DUTY VALVE					
WC	WATER COLUMN			TRIPLE DUTY VALVE					
WT	WATER TIGHT			TRIPLE DUTY VALVE					

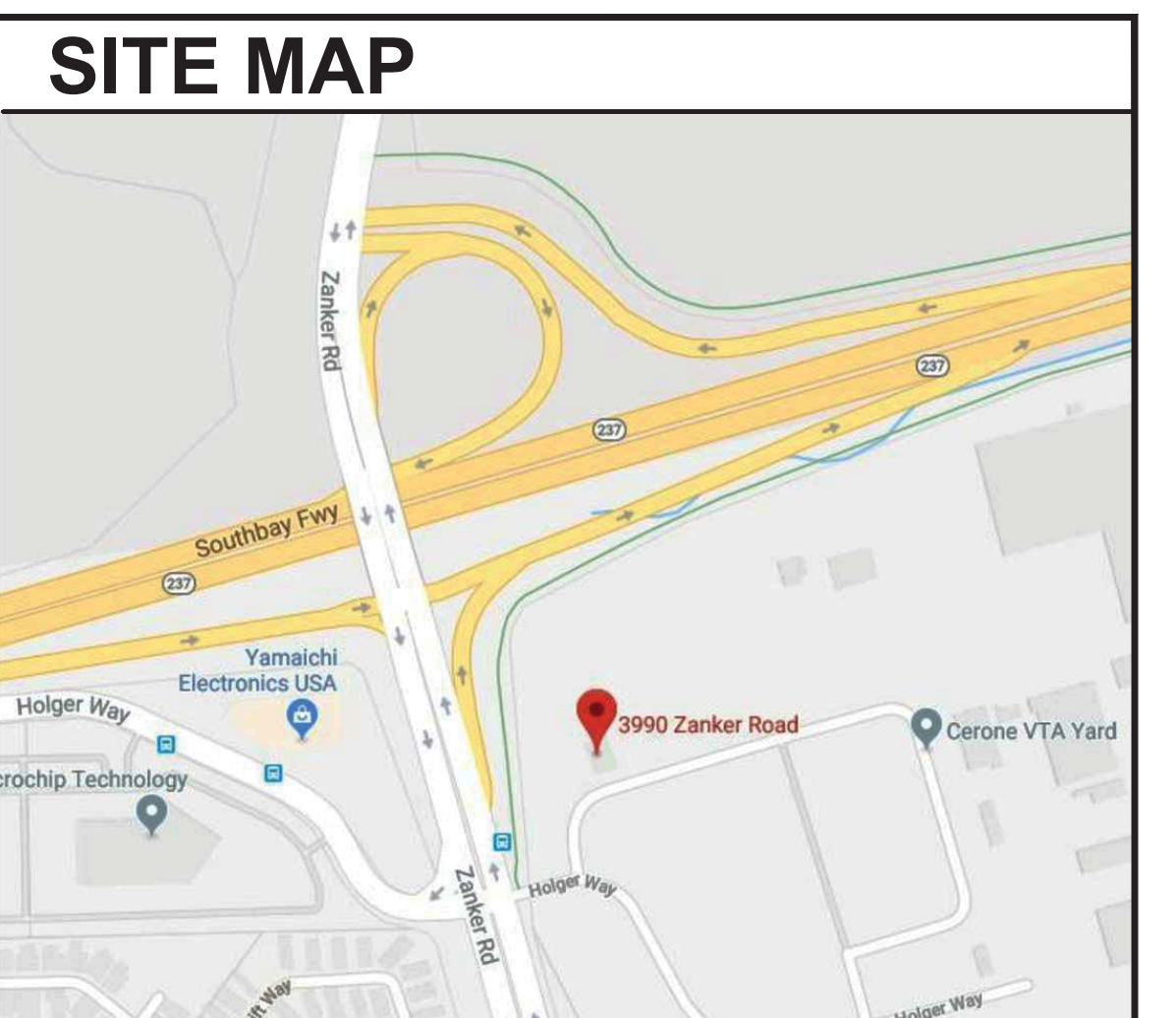

DRAWING INDEX	
SHEET	TITLE
P1	PLUMBING - COVER SHEET
P2	PLUMBING - MATERIAL AND METHODS SCHEDULES
P3.1	PLUMBING - SCHEDULES
P3.2	PLUMBING - SCHEDULES
P3.3	PLUMBING - SCHEDULES
P4	PLUMBING - SITE PLAN - OVERALL
P5	PLUMBING - PROPANE SYSTEM PLAN - ENLARGED
P6	PLUMBING - PROPANE SYSTEM PLAN - ENLARGED
P7	PLUMBING - UNDERGROUND BLDG. F PLAN
P8	PLUMBING - LIQUID & GASEOUS PROPANE STORAGE & DIST. SYSTEM - P&ID
P9	PLUMBING - PROPANE TANK DETAILS
P10	PLUMBING - BUILDING G - UTILITY ROUTING
P11	PLUMBING - BUILDING F - HEATING HOT WATER SYSTEM - P&ID DEMO
P12	PLUMBING - BUILDING F - HEATING HOT WATER SYSTEM - P&ID PROPOSED
P13	PLUMBING - BUILDING F - CENTRAL UTILITIES BUILDING - DEMO PLAN
P14	PLUMBING - BUILDING F - CENTRAL UTILITIES BUILDING - PROPOSED PLAN
P15	PLUMBING - BUILDING B & E - NEW HHW PIPING PLAN
P16	NOT USED
P17	PLUMBING - DETAILS
P18	PLUMBING - DETAILS
P19	PLUMBING - DETAILS
P20	PLUMBING - DETAILS
P21	PLUMBING - DETAILS

- ### LABELING REQUIREMENTS
- LABEL ALL PIPING WITH CONTENTS AND DIRECTION OF FLOW EVERY 20' ON CENTER BEFORE AND AFTER EVERY VALVE, BEFORE AND AFTER EVERY WALL PENETRATION AND AT EACH CHANGE IN DIRECTION.
  - LABEL ALL PIPING, DUCTING AND EQUIPMENT PER ASME A13.1.
  - ALL CONTROLS VALVES SHALL BE LABELED AND LOCATED SO AS TO BE VISIBLE AND READILY ACCESSIBLE.
  - LABEL ALL EQUIPMENT WITH WEATHER AND UV RESISTANT ALUMINUM SUBSTRATE LABEL, MIN. 10"x10" SIZE.
  - CONTRACTOR TO PROVIDE & INSTALL ALUMINUM BACKED WARNING TAPES ON ALL BURIED, UNDER GROUND TRENCH ROUTED HHWS/R, LPG, PG PIPES.

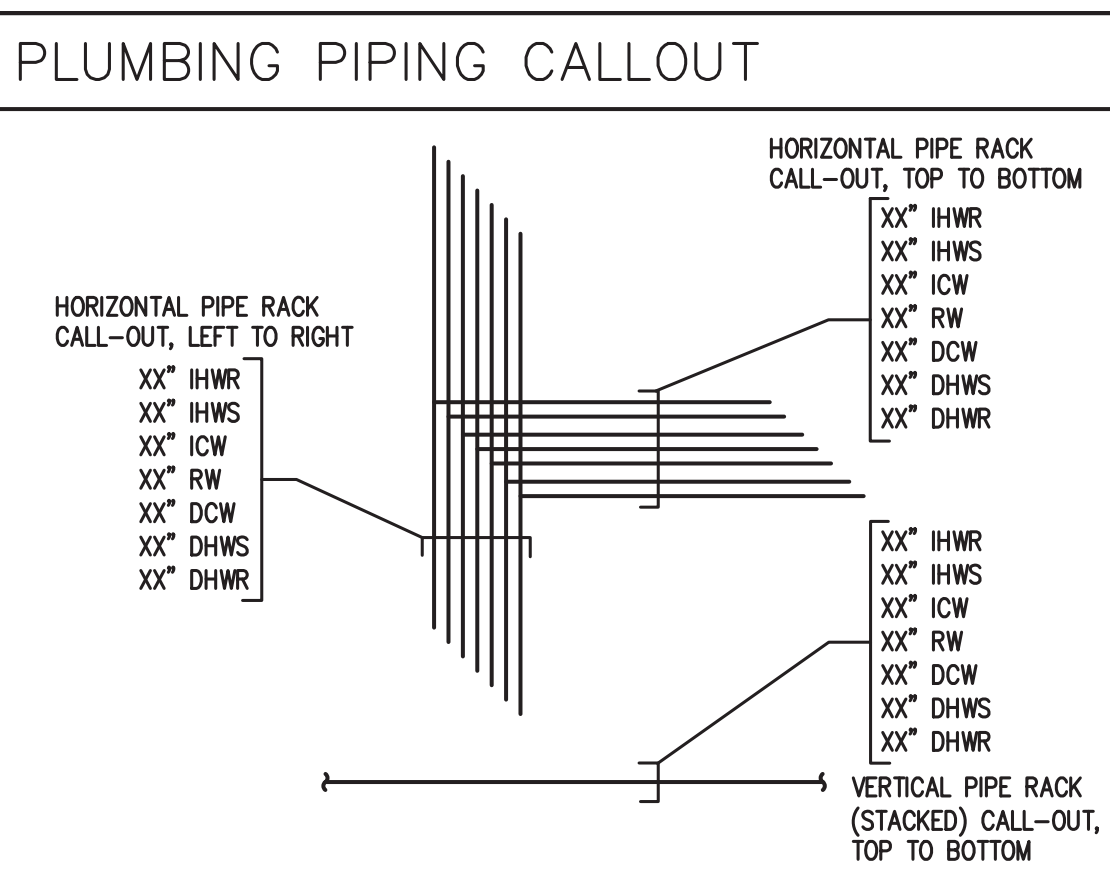

- CONTRACTOR MUST REVIEW ALL PAGES OF THE CONTRACT DOCUMENTS PRIOR TO SUBMITTING A BID PROPOSAL, INCLUDING APPLICABLE PROJECT WIDE NOTES ON DRAWING "G1" AND OTHER DRAWINGS.
- CONTRACTOR IS ADVISED THAT EXISTING LINES AND EQUIPMENT ARE OF VARYING AGES AND STATES OF GOOD REPAIR. CONTRACTOR MUST TAKE PROACTIVE STEPS TO AVOID ADVERSE EFFECTS ON EXISTING EQUIPMENT AFFECTED BY CONTRACTOR'S WORK AND ACTIVITIES. CONTRACTOR MUST PREPARE A CUTOVER WORK PLAN FOR VTA APPROVAL THAT AMONG OTHER ITEMS OF CONCERN DETAILS INTERCONNECTION POINTS BETWEEN NEW CONSTRUCTION AND EXISTING SYSTEMS, AND DETAILS THE CONTRACTOR'S PROACTIVE APPROACH TO PREVENTING ADVERSE EFFECTS ON EXISTING EQUIPMENT AND SYSTEMS.
- PRIOR TO ALTERING OR AFFECTING ANY EXISTING SYSTEMS, EQUIPMENT, OR FACILITIES, CONTRACTOR MUST SURVEY THE EXISTING CONDITION OF ALL EXISTING EQUIPMENT CONNECTED TO SYSTEMS THAT WILL BE MODIFIED BY CONTRACTOR'S WORK. CONTRACTOR MUST REPORT ANY EXISTING EQUIPMENT THAT IS NOT IN GOOD WORKING CONDITION, OR IS IN A DEFICIENT STATE OF REPAIR, PRIOR TO AFFECTING SAID EQUIPMENT.
- ANY EQUIPMENT NOT REPORTED BY CONTRACTOR TO BE DEFICIENT WILL BE PRESUMED TO BE IN GOOD WORKING CONDITION PRIOR TO BEING AFFECTED BY CONTRACTORS WORK.
- SEISMICALLY SUPPORT ALL MECHANICAL EQUIPMENT, PROCESS EQUIPMENT AS SHOWN ON THE STRUCTURAL DRAWINGS, AS REQUIRED BY CODE, OR AS DIRECTED BY THE MANUFACTURER. ALL PIPING MUST BE SEISMICALLY BRACED PER THE SHEET METAL AND AIR CONDITIONING CONTRACTOR'S NATIONAL ASSOCIATIONS (SMACNA'S) SEISMIC RESTRAINT MANUAL, AND TO MEET APPLICABLE BUILDING CODES.
- CONTRACTOR MUST SUBMIT SHOP DRAWINGS (1/4" = 1'-0" SCALE MINIMUM) FOR REVIEW BY VTA PRIOR TO COMMENCING WORK. CONTRACTOR MUST SUBMIT EQUIPMENT, PIPING, AND FIXTURE MATERIAL SUBMITTALS TO VTA FOR REVIEW AND APPROVAL PRIOR TO PURCHASING AND INSTALLATION. REFER TO TECHNICAL SPECIFICATIONS FOR ADDITIONAL INFORMATION.
- CONTRACTOR WILL CONDUCT ANY REQUIRED RIGGING AND MOVING OF PRODUCTION EQUIPMENT. CONTRACTOR MUST COORDINATE SUCH ACTIVITIES WITH VTA AT LEAST TWO WEEKS IN ADVANCE.
- ALL PERSONNEL INVOLVED IN PIPE DEMOLITION MUST WEAR PROPER PERSONAL PROTECTIVE EQUIPMENT (PPE) AND MUST MAKE THE NECESSARY PROVISIONS TO PREVENT EXPOSURE TO HAZARDOUS MATERIALS.
- WELDING OR OPEN FLAME ARE NOT PERMITTED DURING THE DEMOLITION PROCESS OF ANY FLAMMABLE OR COMBUSTIBLE PIPING OR EXHAUST DUCT SYSTEMS.
- DO NOT CONDUCT ANY FIELD WELDING ONSITE WITHOUT PRIOR WRITTEN VTA APPROVAL (TECH. SPEC. SECTION 01 73 00.3.11).**
- CONTRACTOR MUST SUBMIT EQUIPMENT, PIPING, AND FIXTURE MATERIAL SUBMITTALS TO VTA FOR REVIEW AND APPROVAL PRIOR TO PURCHASING AND INSTALLATION.
- ANY NEW OR EXISTING PIPING OFFSETS REQUIRED AS A RESULT OF EXISTING JOB CONDITIONS OR INADEQUATE COORDINATION BETWEEN TRADES, WILL BE PROVIDED AT NO ADDITIONAL COST TO VTA AND BE SUBJECT TO VTA'S REVIEW AND APPROVAL.
- COORDINATE LOCATION OF PIPE RACKS (NEW & EXISTING) WITH OTHER TRADES.
- PROVIDE ANY ADDITIONAL PIPING REQUIRED, AT NO ADDITIONAL COST TO VTA, AND SUBJECT TO VTA'S REVIEW AND APPROVAL.
- UNDER SUSPENDED EQUIPMENT AND PIPING, MAINTAIN A MINIMUM HEAD CLEARANCE OF 90" ABOVE FINISHED FLOOR (AFF).
- PURGING OF FLAMMABLE GAS PIPING SYSTEMS, EXTENDING FROM THE POINT OF DELIVERY TO GAS CONSUMING EQUIPMENT ISOLATION VALVES, MUST BE CONDUCTED IN ACCORDANCE WITH NFPA-56, 2017 EDITION "STANDARDS FOR FIRE & EXPLOSION PREVENTION DURING CLEANING & PURGING OF FLAMMABLE GAS PIPING SYSTEMS"
- ALL MATERIALS USED IN A PLENUM SPACE MUST BE PLENUM RATED.

NO.	DATE	REVISIONS
1	06/01/20	ISSUE FOR BID



SUBMITTED		Integrated Engineering Services 70 SARATOGA AVE. * SUITE 200 SANTA CLARA, CA. 95051-7301 PHONE: (408)261-3500 * FAX (408)261-4176 www.IEEngineering.net	
DESIGNED	TR	CHECKED	LC
DRAWN	HL	CADD FILE NAME	-



APPROVED	
CADD FILE DATE APRIL 15, 2020	SCALE NONE
PLOT DATE -	BOARD APPROVAL DATE

CERONE DIVISION BOILER AND PROPANE TANK REPLACEMENT PLUMBING COVER SHEET			SHEET 11 OF 49 DRAWING NO. P1 REVISION 1
SAP NO.	CONTRACT NO. C19123	FILE LOCATION	



**FLUID PIPING SYSTEMS COMPLIANCE NOTES**

**LEAK TESTING AND CERTIFICATION**

- TEST PIPING SYSTEM IN COMPLIANCE WITH:
- THE 2016 CALIFORNIA MECHANICAL CODE.
  - THE 2016 CALIFORNIA PLUMBING CODE.
  - THE 2016 CALIFORNIA FIRE CODE.
  - AND AS LISTED PER TABLE BELOW, WHICHEVER IS MORE STRINGENT.

**PIPING SYSTEMS PRESSURE TEST TABLE**

SYSTEM	TEST PRESSURE	DURATION	TEST MEDIUM
FUEL GAS PIPING: LOW, MEDIUM & HIGH PRESSURE NATURAL GAS	50 PSIG MIN. OR 150% OPERATING PRESSURE, WHICHEVER IS GREATER	30 MINUTES FOR EACH 500 CU. FT. OF PIPE VOLUME	NITROGEN
NON-HAZARDOUS PROCESS PIPING: (PRESSURIZED)	150% OPERATING PRESSURE WHEN TESTED HYDRAULICALLY, OR 110% OPERATING PRESSURE WHEN TESTED PNEUMATICALLY	30 MINUTES	WATER OR AIR (DI WATER OR NITROGEN FOR HIGH-PURITY APPLICATIONS)
HAZARDOUS PROCESS PIPING: (PRESSURIZED)	100 PSIG MIN., 150% OPERATING PRESSURE WHEN TESTED HYDRAULICALLY, OR 110% OPERATING PRESSURE WHEN TESTED PNEUMATICALLY	30 MINUTES	WATER OR AIR (DI WATER OR NITROGEN FOR HIGH-PURITY APPLICATIONS)
CORROSIVE, TOXIC, HIGHLY-TOXIC AND PYROPHORIC GAS PIPING:	IN ADDITION TO PRESSURE LEAK TEST REQUIRED FOR HAZARDOUS PROCESS PIPING ALL TOXIC, HIGHLY-TOXIC AND PYROPHORIC GAS PIPING SHALL BE HELIUM LEAK CHECKED TO 1x10 <sup>-6</sup> STD. CC/SEC HELIUM. 3rd PARTY PURITY ANALYSIS MAY BE PERFORMED AT OWNER'S DISCRETION. PIPE FITTERS SHALL BE CERTIFIED.		NITROGEN
PLUMBING: (GRAVITY DRAIN, WASTE AND VENT PIPING INCLUDING STORM WATER DRAINAGE AND HAZARDOUS MATERIAL DRAINS)	10 FT. WC HEAD WHEN TESTED HYDRAULICALLY, OR 5 PSIG WHEN TESTED PNEUMATICALLY.	30 MINUTES MIN., PLUS TIME REQUIRED TO INSPECT ALL JOINTS, OR 4 HOURS WHEN TESTED HYDRAULICALLY.	WATER OR AIR
WATER SUPPLY & DISTRIBUTION: DOMESTIC HOT & COLD WATER, INDUSTRIAL WATER, DI AND HIGH PURITY PROCESS WATER	100% MAX. OPERATING PRESSURE, HYDRAULICALLY, OR 50 PSIG MIN. WHEN TESTED PNEUMATICALLY FOR NON-PLASTIC PIPING.	30 MINUTES. NOTE: RATE OF PRESSURIZATION SHALL NOT EXCEED 10 PSIG EVERY 10 MINUTES.	WATER OR AIR (DI WATER OR NITROGEN FOR HIGH-PURITY APPLICATIONS)
PROCESS VACUUM	50 PSIG MIN. OR 150% OPERATING PRESSURE, WHICHEVER IS GREATER	4-HOURS	AIR

NOTE: THIS PRESSURE TESTING TABLE IS GENERALIZED FOR SEVERAL PIPING SYSTEMS. DISREGARD THOSE SYSTEMS AND PIPING NOT USED ON THE DRAWINGS.

**PERMITTING & INSPECTION NOTES**

- CONTRACTOR IS RESPONSIBLE FOR SECURING ALL NECESSARY PERMITS (REFER TO CONTRACT SECTION 6.7).
- ARRANGE AND COORDINATE ALL REQUIRED INSPECTIONS & TESTING WITH APPROPRIATE REGULATORY AUTHORITIES, OVERSIGHT BODIES, AND VTA (REFER TO CONTRACT SECTION 6.7).
- PROVIDE ALL TEST EQUIPMENT, FITTINGS, OR TOOL NECESSARY. CONTRACTOR TO MEET VTA AND REGULATORY TESTING REQUIREMENTS, AT NO ADDITIONAL EXPENSE TO VTA. CONTRACTOR TO SECURE AND PAY FOR ANY THIRD PARTY TESTING LABS OR COMPANIES REQUIRED, AT NO ADDITIONAL EXPENSE TO VTA.
- CONTRACTOR IS RESPONSIBLE FOR CORRECTING ANY DEFICIENCIES IN THEIR WORK CITED BY VTA (OR ANY REGULATORY OVERSIGHT BODIES), AT NO ADDITIONAL EXPENSE TO VTA.
- PROVIDE VTA WITH A COPY OF ALL DOCUMENTS SUBMITTED TO, OR RECEIVED FROM, TESTING COMPANIES, REGULATORY AUTHORITIES, OVERSIGHT BODIES, OR OTHER JURISDICTIONS REGARDING THIS PROJECT, INCLUDING ANY PLAN CHECK COMMENTS AND / OR RESPONSES.

**PIPING SPECIFICATIONS CONTINUED**

**HANGERS, SUPPORTS AND PENETRATIONS:**

- HANGERS AND SUPPORTS: SHALL BE AS MANUFACTURED BY SUPERSTRUT OR UNISTRUT. USE 3/8" HANGER ROD FOR INDIVIDUAL PIPES UP TO 2" AND 1/2" FOR PIPES UP TO 4". SUPPORTS SHALL BE 6" O.C. FOR PIPES 1" AND UNDER AND 8" O.C. FOR PIPES 2" AND OVER.
- DO NOT USE PERFORATED STRAPS FOR PIPING SUPPORT IN WALLS.
- PROVIDE CALCIUM SILICATE INSERTS WHERE INSULATED PIPE CONTACTS A HANGER OR SUPPORT.
- PROVIDE SHEET METAL CANS, MINIMUM 24 GAUGE, FOR PIPE PENETRATIONS THROUGH FLOOR.

**PROPANE GAS (ABOVE GROUND)**

- PROPANE GAS: (ABOVE GROUND)
- LOW PRESSURE PIPING SHALL BE STANDARD WEIGHT SCHEDULE 40 STEEL PIPE CONFORMING TO THE DETAILED PIPE TECHNICAL SPECIFICATIONS:
  - MEDIUM PRESSURE PIPING SHALL BE STANDARD WEIGHT SCHEDULE 40 STEEL PIPE CONFORMING TO THE DETAILED PIPE TECHNICAL SPECIFICATIONS:

**PROPANE GAS (BELOW GROUND)**

- ALL UNDERGROUND PROPANE PIPING SHALL BE: DRISCOPEX® 6500 SERIES HDPE GAS DISTRIBUTION PIPE AS MANUFACTURED BY "PERFORMANCE PIPE" OR EQUAL (FOR DETAILS SEE PIPE TECHNICAL SPECIFICATIONS)
- ALL UNDERGROUND PIPE FIXTURES AND ABOVE GROUND JOINT ADAPTERS SHALL BE PLASSON HDPE PIPE FIXTURES AS MANUFACTURED BY "PERFORMANCE PIPE" OR EQUAL (FOR DETAILS SEE PIPE TECHNICAL SPECIFICATIONS)

**PIPING SPECIFICATIONS**

**DCW, DHW, ICW PIPING:**

- PIPING:
  - 4" AND SMALLER: ABOVE GROUND INSTALLATION: TYPE L HARD-DRAWN SEAMLESS COPPER TUBING, PLAIN ENDS PER ASTM B-88.
  - BELOW GROUND INSTALLATION: TYPE K HARD-DRAWN OR SOFT SEAMLESS COPPER TUBING, PLAIN ENDS PER ASTM B-88.
- FITTINGS:
  - 2" AND SMALLER: WROUGHT COPPER SOLDER TYPE FITTINGS PER ANSI STANDARD B16.22 OR CAST RED BRONZE PER ANSI B16.18. ALL SOLDER SHALL BE NOT LESS THAN 95% TIN, 5% ANTIMONY.
  - 2-1/2" AND LARGER: WROUGHT COPPER, BRAZED SOLDER-TYPE FITTINGS PER ANSI B 16.22. USE 15 PERCENT SILVER BRAZING ALLOY AND BRAZING FLUX.
- UNIONS:
  - 2" AND SMALLER: BRONZE IPS UNIONS WITH COPPER TO IPS ADAPTERS.
- FLANGES:
  - 2-1/2" AND LARGER: 125 LBS. ASME STANDARD CAST BRONZE BRAZED SOLDER-TYPE JOINT PER ASME B16.5.
- VALVES:
  - VALVES FOR SHUT-OFF SERVICE SHALL BE GATE OR FULL-PORT BALL TYPE.
  - GATE VALVES:
    - 2" AND SMALLER: NIBCO, CRANE, STOCKHAM OR EQUAL. NIBCO T-134, CLASS 150, BRONZE GATE VALVE, BLOCK PATTERN, UNION BONNET, RISING STEM, SOLID WEDGE DISC, THREADED. LEAD FREE PER NSF/ANSI 61 AND NSF/ANSI 372
    - 2-1/2" AND LARGER: NIBCO, CRANE, STOCKHAM OR EQUAL. NIBCO F-616-0, CLASS 125, CAST IRON GATE VALVE, BOLTED BONNET, OUTSIDE SCREW AND YOKE, SOLID WEDGE DISC, BRONZE MOUNTED, FLANGED.
  - BALL VALVES:
    - 2" AND SMALLER: NIBCO, CRANE, STOCKHAM OR EQUAL. NIBCO T-595-Y-LF, CLASS 150, BRONZE BALL VALVE, THREE-PIECE BODY, FULL PORT, BRONZE TRIM, BLOWOUT-PROOF STEM, EXTENDED INSULATION HANDLE, THREADED. LEAD FREE PER NSF/ANSI 61 AND NSF/ANSI 372
- PIPE JOINTS:
  - SCREWED: APPLY PERMACEL P-412 1/2 INCH WIDE WHITE TEFLON PIPE JOINT SEALANT TAPE TO MALE PIPE THREADS WHEN MAKING UP JOINTS.
  - SOLDERED: USE STAY-BRITE 8 OR STAY-BRITE BY HARRIS, AND NON-CORROSIVE FLUX ON EXPOSED JOINTS.
  - BRAZED: USE 15 PERCENT SILVER BRAZING ALLOY, STAY-SILV 15 AND BRAZING FLUX ON JOINTS 2-1/2" AND LARGER, AND ON CONCEALED OR BELOW GRADE JOINTS.
  - UNIONS: BRONZE IPS UNIONS WITH COPPER TO IPS ADAPTERS. INSTALL DOWNSTREAM OF VALVES. USE EPCO DIELECTRIC COUPLINGS FOR CONNECTIONS BETWEEN DISSIMILAR METALS SHALL MEET ASME B16.39. LEAD FREE PER NSF/ANSI 61 AND NSF/ANSI 372
  - INSULATION:
    - COLD WATER 1" THK (R=0.23-0.27) AND HOT WATER 1-1/2" THK, (R=0.25-0.29) PREFORMED FIBERGLASS INSULATION WITH ALL WEATHER JACKET, DOUBLE SELF-SEATING LAP AS MANUFACTURED BY OWENS CORNING, KNAUF OR MANSVILLE WITH LAMINATED WHITE KRAFT PAPER REINFORCED FOIL JACKET WITH PVC FITTING COVERS. FOR EXPOSED PIPING USE A PVC JACKET FOR PERSONNEL PROTECTION.
    - FITTINGS SHALL BE FINISHED WITH ZESTON, KNAUF OR CHILDERS FITTING CLOSURES.

**PIPING MATERIAL SPECIFICATIONS**

**HEATING HOT WATER**

- PIPE: ABOVE GROUND INSTALLATION 2-1/2" AND LARGER: SEAMLESS SCH. 40 CARBON STEEL TO ASTM A-106, GRADE-B, STD. WT. PLAIN ENDS OR ROLL GROOVED. JOINTS: WELDED TO ANSI B31.2, THREADED TO ANSI B31.9. VICTAULIC IS ACCEPTABLE. ABOVE & UNDERGROUND INSTALLATION.
  - 2" AND SMALLER: HARD DRAWN TYPE "L" OR "K" COPPER TO ASTM B28. JOINING: 15% SILVER BRAZING TO AWS A5.8 TYPE. USE NO FLUX. HEATING HOT WATER PIPE: UNDERGROUND HARD DRAWN TEMPERED TYPE "K" COPPER TUBE ASTM B88 JOINT: 15% SILVER BRAZING TO AWS A5.8 TYPE BcUp.5 FITTING: WROUGHT COPPER & COPPER ALLOY BRAZE JOINT PRESSURE FITTINGS ASME B16.50.
- FITTINGS:
  - 2-1/2" AND LARGER: CARBON STEEL WELDED FITTINGS, BUTT WELD TYPE TO ASTM A-234, GRADE WFB, ANSI B16.9, STD. WT. FLANGES AND UNIONS: 2-1/2" AND LARGER: CARBON STEEL FLANGES, SLIP-ON OR WELD NECK, CLASS 150 TO ANSI B16.5 AND ASTM A-105.
  - 2" AND SMALLER: HARD DRAWN TYPE "K" COPPER TO ASTM B28. JOINING: 15% SILVER BRAZING TO AWS A5.8 TYPE. USE NO FLUX.
- VALVES:
  - 2-1/2" AND LARGER: CLASS 125, CAST IRON GATE VALVE, BOLTED BONNET, OS&Y, SOLID WEDGE DISC, BRONZE MTD. FLG. NIBCO F-616-0, CRANE OR STOCKHAM. BUTTERFLY VALVE: NIBCO LD-2000, 200 PSIG, LUG TYPE BUTTERFLY VALVE, DUCTILE IRON BODY, EPDM RUBBER SEAL ALUMINUM BRONZE DISC, EXTENDED INSULATION NECK, GEOMETRIC DRIVE, SS STEM, BRONZE BUSHINGS, MOLDED-IN SEAT LINER, FLANGED. CRANE OR STOCKHAM OR VICTAULIC #300 GROOVED END BUTTERFLY VALVES OR APPROVED EQUAL.
  - SWING CHECK VALVE: NIBCO F-918-B, CLASS 125, CAST IRON CHECK VALVE, BOLTED BONNET, HORIZ. SWING, RENEWABLE BRONZE SEAT AND DISC, FLANGED. CRANE, STOCKHAM OR VICTAULIC STYLE #716 OR APPROVED EQUAL.
  - TRIPLE DUTY VALVES: COMBO NON-SLAM CHECK, BALANCING AND SHUTOFF VALVE AS MFR'D. BY BELL & GOSSSETT. ARMSTRONG, WHEATLY OR APPROVED EQUAL.
  - 2" AND SMALLER: BALL VALVE: NIBCO W-595-Y THREE PIECE BODY, FULL PORT. CRANE, STOCKHAM OR APPROVED EQUAL.
- PIPE INSULATION ABOVE GROUND:
  - HEATING HOT WATER: 2" THICK PRE-MOLDED FIBROUS GLASS ASJ WITH 0.016" ALUMINUM JACKET. INSULATION CONDUCTIVITY RANGE: 0.25-0.29 BTU-INCH PER HOUR PER SF PER F. INSULATION MEAN RATING TEMPERATURE (T<sub>m</sub>) OF 125° F. MAX 0.02 PER INCH WATER VAPOR PERMEABILITY. JACKET SHALL BE SMOOTH, CORRUGATED, OR EMBOSSED FINISH WITH FACTORY-APPLIED MOISTURE BARRIER. OVERLAP SHALL BE 2-INCH (50 MM) MINIMUM. FITTINGS SHALL BE DIE-SHAPED WITH FACTORY-APPLIED MOISTURE BARRIER.
  - PIPE INSULATION BELOW GROUND:
    - HIGH TEMPERATURE FOAM INSULATION WITH:
      - K FACTOR = 0.165
      - DENSITY OF 2 PCF
      - COMPRESSIVE STRENGTH: MIN. 35 PSI
      - MINIMUM INSULATION THICKNESS OF 1.2" FOR 1-1/2" PIPE
      - JACKETING MATERIAL: HIGH IMPACT, SEAMLESS PVC CLASS 12454-B (ASTM 1784 TYPE 1, GRADE 1)
      - MINIMUM JACKET THICKNESS 60 MILLS
      - SIZE: 4"ø FOR 1-1/2" CARRIER PIPE.

**RECONNECTED SERVICE TEST**

- PROPANE GAS DISTRIBUTION SYSTEM: ALL EXISTING PROPANE GAS DISTRIBUTION SYSTEM COMPONENTS (VALVES, PRESSURE REGULATORS, GAUGES & INDICATORS, GAS TRAIN COMPONENTS, VENTS) SHALL BE TESTED, ADJUSTED FOR PROPER OPERATION AND REPLACED IF LEAKING OR NON FUNCTIONAL PRIOR TO SYSTEM STARTUP AND ONLINE OPERATION.
- HHWS/R DISTRIBUTION SYSTEM: (EXCLUDES INTERIOR OF BUILDING B, E, G) ALL EXISTING HHWS/R DISTRIBUTION SYSTEM COMPONENTS (VALVES, PRESSURE REGULATORS, FLOW BALANCING DEVICES, PRESSURE GAUGES, TRANSMITTERS, TEMPERATURE PROBES, FLOW METERS, DRAIN VALVES, AIR VENTS, STRAINERS, FILTERS) SHALL BE CLEANED AND TESTED FOR PROPER OPERATION AND REPLACED IF LEAKING, MALFUNCTIONING PRIOR TO SYSTEM START UP AND ONLINE OPERATION.

NO.	DATE	REVISIONS
1	06/01/20	ISSUE FOR BID



SUBMITTED

**Integrated Engineering Services**  
 70 SARATOGA AVE. \* SUITE 200  
 SANTA CLARA, CA. 95051-7301  
 PHONE: (408)261-3500 \* FAX (408)261-4176  
 www.IESengineering.net

DESIGNED TR      CHECKED LC

DRAWN HL      CADD FILE NAME -

**Santa Clara Valley Transportation Authority**

APPROVED

CADD FILE DATE: APRIL 15, 2020

SCALE: NONE

PLOT DATE: -

BOARD APPROVAL DATE: -

**CERONE DIVISION**  
**BOILER AND PROPANE TANK REPLACEMENT**

**PLUMBING MATERIALS & METHODS SCHEDULES**

SHEET 12 OF 49 DRAWING NO. P2 REVISION 1

SAP NO.      CONTRACT NO. C19123      FILE LOCATION



BOILER MAKE UP WATER TREATMENT SYSTEM (FOR BOILERS AT BLDG F)	
TAG	DESCRIPTION
WTS-F-1	PROVIDE WATER TREATMENT SYSTEM NALCO 3D TRASAR SERIES 5500 (OR EQUAL) SYSTEM SHALL BE ENCLOSED FRAME MOUNT WITH JUNCTION BOX MODEL #060-TR5521.88 TO MAINTAIN REQUIRED WATER CHEMISTRY LISTED BELOW: HARDNESS: 5-12 GRAINS/GALLON PH: 6.5-8.5 TDS: < 350 PPM CHLORIDE: < 150 PPM  CONTRACTOR SHALL TAKE WATER SAMPLES AND HAVE SAMPLES TESTED PRIOR TO FINAL DETERMINATION OF CHEMISTRIES TO BE USED IN WATER TREATMENT SYSTEM.  ALLOW 1/2 DAY FOR SYSTEM TRAINING ACTIVITIES AT VTA.

HOT WATER FILTER SCHEDULE														5/14/2020		
TAG	MFR	MODEL	GPM	dP (PSID)	TYPE	FILTER CARTRIDGE				INLET SIZE (IN)	OUTLET (IN)	HOUSING HT (IN)	HOUSING DIAM (IN)	WBGHT (LBS)	NOTES	
						MOD#	DIA-OD	HEIGHT	RATING							TEMP RATING
F-FL-01	HARMSCO	WB90SC-2	115	3	Multi Cartridge	HC/90-SCPHT	7-3/4"	19-1/2"	0.5 Mic	200 F	2	2	29 3/8	13	51	FLOOR STANDING BOTTOM INLET/OUTLET
F-FL-02	HARMSCO	WB90SC-2	115	3	Multi Cartridge	HC/90-SCPHT	7-3/4"	19-1/2"	0.5 Mic	200 F	2	2	29 3/8	13	51	FLOOR STANDING BOTTOM INLET/OUTLET
1 INSTALL FILTERS NEAR PIPE RACK BEHIND BACK OF BOILERS 2 INSTALL TEE AND 1" BALL DRAIN VALVE AT BOTTOM FACING TOWARDS THE NEAREST FLOOR SINK 3 INSULATE FILTER HOUSING WITH MIN 2" THICK ARMAFLEX INSULATION.																



SUBMITTED  
  
**Integrated Engineering Services**  
 70 SARATOGA AVE. \* SUITE 200  
 SANTA CLARA, CA. 95051-7301  
 PHONE: (408)261-3500 \* FAX (408)261-4176  
 www.IEEngineering.net  
 DESIGNED TR CHECKED LC  
 DRAWN HL CADD FILE NAME -



APPROVED  
  
 CADD FILE DATE APRIL 15, 2020 SCALE NONE  
 PLOT DATE - BOARD APPROVAL DATE -

CERONE DIVISION  
 BOILER AND PROPANE TANK  
 REPLACEMENT  
 PLUMBING  
 SCHEDULES  
 SHEET 13 OF 49 DRAWING NO. P3.1 REVISION 1  
 SAP NO. CONTRACT NO. C19123 FILE LOCATION

NO.	DATE	REVISIONS
1	06/01/20	ISSUE FOR BID



LPG Tank Schedule												
TAG Number	Make	Orientatio	Diameter	Length/Height	Size	Weight [lbs]		MAWP	MOT	Tank Support		Remarks
						Dry	Full(*)			[psig]	[F]	
LPG-02	Trinity LLC.	Horizontal	109.346	791 3/8"	30,000	~47,000 lbs	~155,000 lbs	250	125	Saddle	2 ea	(*)Full weight is estimated at max 85% Liquid level

LPG Tank Nozzle & Connected Component Schedule												
Nozzle ID	Quantity	Size	Location	Connection Type	Service	Flow Rate	Connected component	Provided by	Model #	Model #	Set Point	Remarks
A	1	2-1/2"	Front Center	3000# Half Coupling	Float Gauge Connection	N/A	Float Gauge	Tank Manufacturer				See PST-LM1 Float Gauge System specification details under Tank & Fill Station Accessory List
B	1	3/4"	Front Center 33deg UP	6000# SPCL Coupling w/#54 Hole	Press. Gauge Connection	N/A	Liquid Level & Press. Gauge	Tank Manufacturer				
C	1	3/4"	Front Center 13deg DOWN	6000# Full Coupling	Thermo Well Connection	N/A	Thermo Well	Tank Manufacturer				
D	1	2"	Rear Center	3000# Half Coupling	Rotary Gauge Connection	N/A	Rotary Gauge	Tank Manufacturer				See PST-L11 Rotogauge System specification details under Tank & Fill Station Accessory List
E	1	3"	Bottom Front Center	5-1/2" OD SPCL Coupling	LIQUID OUT Connection	236	Distribution Pipe	Installer				
F	1	2"	Bottom Front Center	3000# Half Coupling	LIQUID FILL Connection		Fill Pipe	Installer				
G	1	2"	Top Front Center	3000# Half Coupling	Tank Vapor Space	N/A	Tank (Vapor) pressure control	Tank Manufacturer				
H	1	2"	Bottom Front Center	3000# Half Coupling w/pipe	Tank Vapor Space OUT	N/A	Tank Vapor Space evacuation	Tank Manufacturer				
J	1	2"	Top Rear Center	3000# Half Coupling	Pressure relief connection		Pressure Relief Valve	Tank Manufacturer				
K	1	2"	Top Rear Center	3000# Half Coupling	Pressure relief connection		Pressure Relief Valve	Tank Manufacturer				
L	1	2"	Top Rear Center	3000# Half Coupling	Pressure relief connection		Pressure Relief Valve	Tank Manufacturer				
N	1	TBD	TBD	TBD	Auxiliary	N/A	TBD	Tank Manufacturer				
MW	1	16"	Front Center 56deg UP	150# RF Pad Flange w/Cover Assy	Manway	N/A	Tank interior access	Tank Manufacturer				

30,000 Gal LPG Storage Tank & Fill Station Accessory List													
TAG Number	Unit Name	Location	Make	Type	Model/Part #	Capacity	Service Requirements			Size/Dimension in	Unit No. [ea]	Weight lb	Remarks
							CDA	N2	Volt-Ph				
PST-L11	Level Indicator	Rear Center Nozzle	RegO	RotoGage	A9095TS	Dip Tube L: 48-3/8"	n/a	n/a	n/a	1" NPT	1	-	Mechanical hand adjustable dip tube positioner for initial level sensing/Visual Indication only. Provide 2"x1" bushing at tank connection to connect 2" half coupling to 1" NPT instrument.
PTR-IV1	Fill Line SOV	Fill Station	RegO	Globe valve (Manual) w/auto back check	HA7513AP	75 GPM @ 1 PSID	n/a	n/a	n/a	2" F NPT	1	-	
PTR-IV2	Vapor Return Line SOV	Fill Station	RegO	Globe valve (Manual) w/auto back check	HA7513AP	75 GPM @ 1 PSID	n/a	n/a	n/a	2" F NPT	1	-	
PTR-FI1	Flow Indicator	Fill Station	RegO	Sight Flow Indicator	A7794	N/A	n/a	n/a	n/a	2" F NPT	1	-	
PTR-ES1	Emergency Shut-off Valve (ESV)	In Fill line	RegO	Pneumatic actuated Swing Check Valve	Valve: A6016 Actuator:6016-60C	640 gpm @ 10 psid	n/a	Yes	n/a	2" F NPT	1		Pneumatic remote shutdown system kit - REGO Mod#6016PN50 (or Equal) includes 100' melt away pneumatic tubing w/fittings, Charging valve assembly, 1 remote shutdown valve assembly
PTR-ES2	Emergency Shut-off Valve (ESV)	In Vapor return line	RegO	Pneumatic actuated Swing Check Valve	Valve: A6016 Actuator:6016-60C	640 gpm @ 10 psid	n/a	Yes	n/a	2" F NPT	1		Pneumatic remote shutdown system kit - REGO Mod#6016PN50 (or Equal) includes 100' melt away pneumatic tubing w/fittings, Charging valve assembly, 1 remote shutdown valve assembly
PST-RV2	Pressure Relief Valve	In Fill line	RegO	External Hydrostatic Relief Valve	SS8022G	1/2"	n/a	n/a	n/a	1/2" M NPT	3		To be installed in LP piping sections between SOVs
PST-IV5	Internal Liquid Supply Valve	Tank Liquid Out Nozzle (Bottom)	RegO	Internal Liquid Supply Valve w/pneumatic actuator	Valve: A3213D150 Actuator: A3213PA	150 gpm closing	n/a	Yes	n/a	3" F NPT	1		Provide min. 3' of 1/4" pneumatic "melt away" tubing at the final termination
PST-IV4	Internal Vapor Transfer Valve	Tank Vapor Space Nozzle (Top)	RegO	Internal Vapor Transport Valve w/pneumatic actuator	Valve: A3212R -105 Actuator: A3213PA	105 gpm closing	n/a	Yes	n/a	2" F NPT	1		Provide min. 3' of 1/4" pneumatic "melt away" tubing at the final termination
PST-IV3	Internal Liquid Fill Valve	Tank Fill Nozzle (Bottom)	RegO	Internal Fill Valve w/pneumatic actuator	Valve: A3212R -105 Actuator: A3213PA	105 gpm closing	n/a	Yes	n/a	2" F NPT	1		Provide min. 3' of 1/4" pneumatic "melt away" tubing at the final termination
PST-IV2	Internal Vapor Return Valve	Tank Vapor Space Nozzle (Bottom)	RegO	Internal Vapor Return Valve w/pneumatic actuator & Vapor space extension tube	Valve: A3212R -105 Actuator: A3213PA	105 gpm closing	n/a	Yes	n/a	2" F NPT	1		Factory installed Vapor Space Extension tube. Provide min. 3' of 1/4" pneumatic "melt away" tubing at the final termination
PST-RV1	Tank Pressure Relief Valves	Tank Pr. Relief Nozzles (Top)	RegO	External "Pop Action" Pressure Relief Valve w/extension tube	A3149G	10390 scfm (@ 120% set pressure -UL)	n/a	n/a	n/a	Inlet: 2-1/2" F NPT Outlet: 3-1/2" M NPT	3 required		Will accept 3" M NPT Pipe Away extension w/ raincap
PTR-HV1	Pull-Away Valves	Tank fill and vapor return hoses	RegO	Quick disconnect type of safety shut off valve	A2141A16	250 gpm @ 5 psig	n/a	n/a	n/a	In/Out 2" NPTF	2		
PST-IV1,1B	Liquid/Vapor Line Isolation Valves	Liquid Transfer-, Vapor Return-, Transfer Lines	RegO	"V" ring seal Globe or Angle Valves	A7513AP/AP7514AP	75/88.5 gpm	n/a	n/a	n/a	Line Size FNPT	7		
PTR-TCV	Pneumatic System Charge Valve	Fill Station bulk head	RegO	Customized assembly	6016PN50	N/A	n/a	n/a	n/a		1		This valve is part of a customized assembly for pneumatic control of LPG storage tank filling and evacuation operations
PTR-TEV	Pneumatic Actuator Emergency Valve	Fill Station bulk head	RegO	Customized assembly	6016PN51	N/A	n/a	Yes	n/a		1		This valve is part of a customized assembly to shutoff the pneumatic actuators of LPG storage tank filling and evacuation valves in case of emergency
PDI-PG1	Pressure Gauge	Multiple	RegO	Regular round gauge w/isolation valve	5548	0-60 PSIG	n/a	n/a	n/a	1/4" MNPT	TBD		W/RegO 1224WA -Needle isolation valve.
FTLS1	Transfer Skid	At Truck Off Load	Transtech Energy	2 Port vertical bulkhead	MC331	2" Full Coupling	n/a	n/a	n/a	4'-3"(H) x 4'-9"(D) x 3"(W)	1		NFPA 58, API2510 Compliant. Provide assembly and concrete footing per vendor's shop drawings and details. Footing concrete to match tank footing requirements. Assume min. foundation depth of 36".
SV1	Low Voltage Solenoid Valve	LPG & PG Out SOV pneumatic lines	ASCO	3/8" Explosion and water proof,	8263H117	N/A	n/a	Yes	24 V-A/C	3/8"	1		Can be mounted on concrete pedestal below LPG Tank Saddle.
PST-LM1	Float Gauge System	Front Center Nozzle	Squibb-Taylor Products	8" SS Dial for LPG	ME3650B	N/A	n/a	n/a	n/a	2-1/2"	1		Mounting hardware: Mod#5331 flange adaptor, 3-Bkt Kit Post 07, Stud Bolt/Nut kit, Master Gasket & centralizer Kit. Dial type must be "remote ready" so that in the future VTA can monitor tank level via their networked ALC system.
PST-LM2	Xact Satellite Radio Transmitter	Strap-On at the middle of the tank	Schmitt Industries	Battery operated, strap/magnet mounted	XACT15096	N/A	n/a	n/a	7.2 Volt	4.92"Lx3.15"Wx2.87"D	1		Xact Tank Level Monitoring System, external power independent 7.2 Volt LTC battery Package included. Measurable minimum tank fill level is 20%
	Xact Ultrasonic Level Transducer			Battery operated, strap/magnet mounted	XACT31012	N/A	n/a	n/a	7.2 Volt	4.0"Lx4.0"Wx1.34"D	1		

NO.	DATE	REVISIONS
1	06/01/20	ISSUE FOR BID



SUBMITTED		 Integrated Engineering Services 70 SARATOGA AVE. * SUITE 200 SANTA CLARA, CA. 95051-7301 PHONE: (408)261-3500 * FAX (408)261-4176 www.IEEngineering.net	
DESIGNED	TR	CHECKED	LC
DRAWN	HL	CADD FILE NAME	-



APPROVED	
CADD FILE DATE	SCALE
APRIL 15, 2020	NONE
PLOT DATE	BOARD APPROVAL DATE
-	-

CERONE DIVISION BOILER AND PROPANE TANK REPLACEMENT		
PLUMBING SCHEDULES		
SAP NO.	CONTRACT NO. C19123	FILE LOCATION

SHEET	14
OF 49	
DRAWING NO.	P3.2
REVISION	1



LP VAPORIZER Schedule													
TAG Number	Make	Type	Height [in]	Width [in]	Depth [in]	Capacity		Weight [LB]	MAWP [psig]	Power [Volt/Phase]	Pressure Vessel		Remarks
						[MBTU/H]	[GPH]				Type	Rating	
VAP-1	RANSOME RH240	Direct Fire	60	33	30	21.96	240	640	250	110V/1PH	Vertical	ASME	Vaporizer is pre-plumbed with Remote Thermal Element w/Safety Shut down by pneumatic trigger.
VAP-2	RANSOME RH240	Direct Fire	60	33	30	21.96	240	640	250	110V/1PH	Vertical	ASME	Vaporizer is pre-plumbed with Remote Thermal Element w/Safety Shut down by pneumatic trigger.

LP VAPORIZER Connected Component Schedule													
TAG Number	Component	Make	Model No	Location	Capacity [MBTU/H]	Connection Type [In/Out]	Outlet Pressure Range [psig]	Max Operating Pressure [psig]	Connected component Name	Provided by	Installed & Pressure Test by	Set Point	Remarks
PDI - PR2	Vaporizer Discharge Pressure Regulator	Fisher	99-513P	Vaporizer discharge pipe	36,368	2 1/2" FNPT	2 to 10	250	Site Supply Main	Contractor	Contractor	5 psig	
PDI - PR1	LPG Tank Pressure Regulator	Fisher	99-513P	Vaporizer discharge pipe	36,368	2 1/2" FNPT	2 to 10	250	Tank Vapor Discharge pipe	Contractor	Contractor	5 psig	LPG Tank Vapor space pressure control
PDI - ES1	Emergency Shut Off Valve (ESV)	Marshall Excelsior	ME980C-8	Liquid Inlet pipe	N/A	1" FNPT	N/A	400	Tank Liquid Discharge pipe	Contractor	Contractor	N/A	At 2 ea locations
PDI - RV1	Pop-Action Pressure Relief Valve	RegO	3131G	Propane Gas discharge header	2060 scfm	3/4" MNPT	N/A	80	Propane Gas Distribution piping	Contractor	Contractor	80 psig	
PDI - ST1	Liquid Strainer	Squibb & Taylor	200712	Vaporizer inlet pipe	N/A	1" FNPT	N/A		N/A	Contractor	Contractor	N/A	At 2 ea locations
PDI - RV2	External Hydrostatic Relief Valve	RegO	SS8022G	LPG supply between LPG Tank & Vaporizers	N/A	1/2" MNPT	N/A	250	N/A	Contractor	Contractor	150 psig	
PDI - IV1	Isolation Valves	RegO	A7513AP	Vaporizer discharge pipe	N/A	2 1/3" 1/4" FNPT	N/A	250	N/A	Contractor	Contractor	N/A	4ea 2", 1ea 3" and 2ea 4" size
PDI-EQ1	Inline Separator	Ransome	I5310R	PG Supply Main	N/A	3"-150#RF	N/A	N/A	N/A	Contractor	Contractor	N/A	



SUBMITTED

**Integrated Engineering Services**  
 70 SARATOGA AVE. \* SUITE 200  
 SANTA CLARA, CA. 95051-7301  
 PHONE: (408)261-3500 \* FAX (408)261-4176  
 www.IEEngineering.net

DESIGNED TR CHECKED LC  
 DRAWN HL CADD FILE NAME -



APPROVED

CADD FILE DATE APRIL 15, 2020 SCALE NONE  
 PLOT DATE - BOARD APPROVAL DATE -

CERONE DIVISION  
 BOILER AND PROPANE TANK  
 REPLACEMENT  
 PLUMBING  
 SCHEDULES

SHEET 15 OF 49 DRAWING NO. P3.3 REVISION 1

SAP NO. CONTRACT NO. C19123 FILE LOCATION

NO.	DATE	REVISIONS
1	06/01/20	ISSUE FOR BID

**GENERAL NOTES:**

- A. FOR UNDERGROUND UTILITIES, REFER TO CIVIL DRAWINGS.
- B. THE EXISTING EMERGENCY GENERATORS AT BUILDING F REQUIRE HIGHER PRESSURE PROPANE GAS THAN WHAT THE NEW SYSTEM WILL PROVIDE. AS PART OF A SEPARATE PROJECT THOSE GENERATORS ARE BEING DEMOLISHED. THE EXISTING PROPANE TANK AND ASSOCIATED HIGH PRESSURE VAPORIZER AND HIGH PRESSURE PIPING DISTRIBUTION CAN NOT BE DEMOLISHED UNTIL THE BUILDING F EMERGENCY GENERATORS ARE DECOMMISSIONED, COORDINATE WITH VTA.

**KEYED NOTES:**

- ① NEW PROPANE SYSTEM INCLUDING PROPANE TANK AND VAPORIZERS. SEE SHEET P5.
- ② SEE DRAWING D1 FOR DEMOLITION SCOPE IN THIS BUILDING.
- ③ EXISTING VAPORIZERS TO BE DEMOLISHED AFTER NEW PROPANE SYSTEM IS INSTALLED AND OPERATIONAL, AND AFTER NO LONGER NEEDED BY THE EMERGENCY POWER GENERATORS IN BUILDING F.
- ④ EXISTING PROPANE GAS REGULATOR AND SERVICE TO BUILDING K BOILER TO REMAIN.
- ⑤ EXISTING PROPANE GAS REGULATOR AND SERVICE TO BUILDING H HVAC AND WATER HEATING EQUIPMENT TO REMAIN.
- ⑥ THE EXISTING CENTRAL PROPANE FUELED HEATING HOT WATER BOILER SYSTEM CURRENTLY SERVING BUILDINGS B, E, AND G TO BE REUSED.

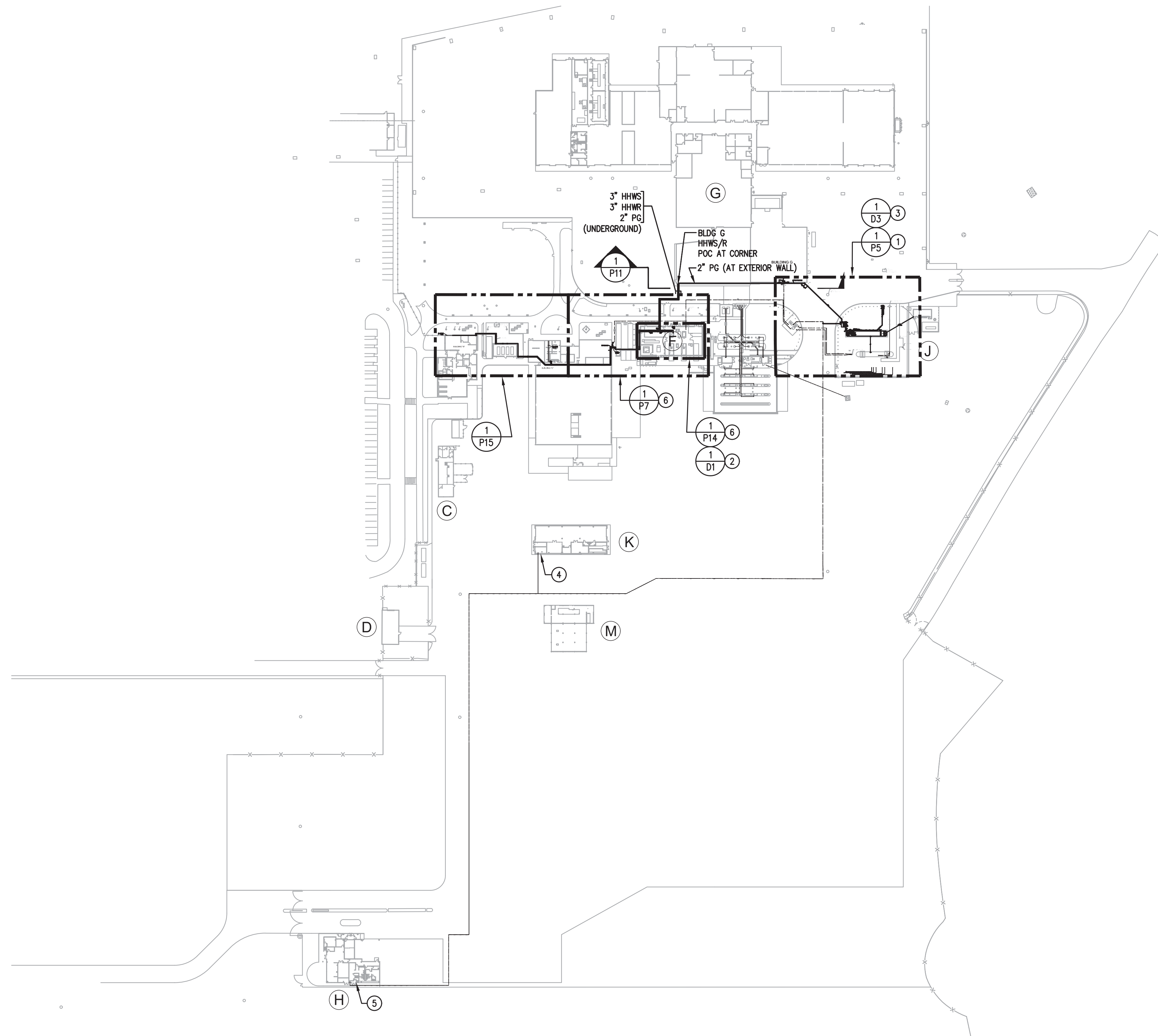

1 PLUMBING - SITE PLAN - OVERALL  
1"=100'-0"

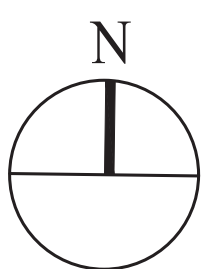

			SUBMITTED  Integrated Engineering Services 70 SARATOGA AVE. * SUITE 200 SANTA CLARA, CA. 95051-7301 PHONE: (408)261-3500 * FAX (408)261-4176 www.IEEngineering.net		APPROVED  CADD FILE DATE APRIL 15, 2020		SCALE AS NOTED		CERONE DIVISION BOILER AND PROPANE TANK REPLACEMENT PLUMBING SITE PLAN - OVERALL		SHEET 16 OF 49
1	06/01/20		ISSUE FOR BID	DESIGNED TR	CHECKED LC	PLOT DATE -	BOARD APPROVAL DATE -	DRAWN HL			CADD FILE NAME -
NO.	DATE	REVISIONS		Santa Clara Valley Transportation Authority				SAP NO. CONTRACT NO. C19123		FILE LOCATION	



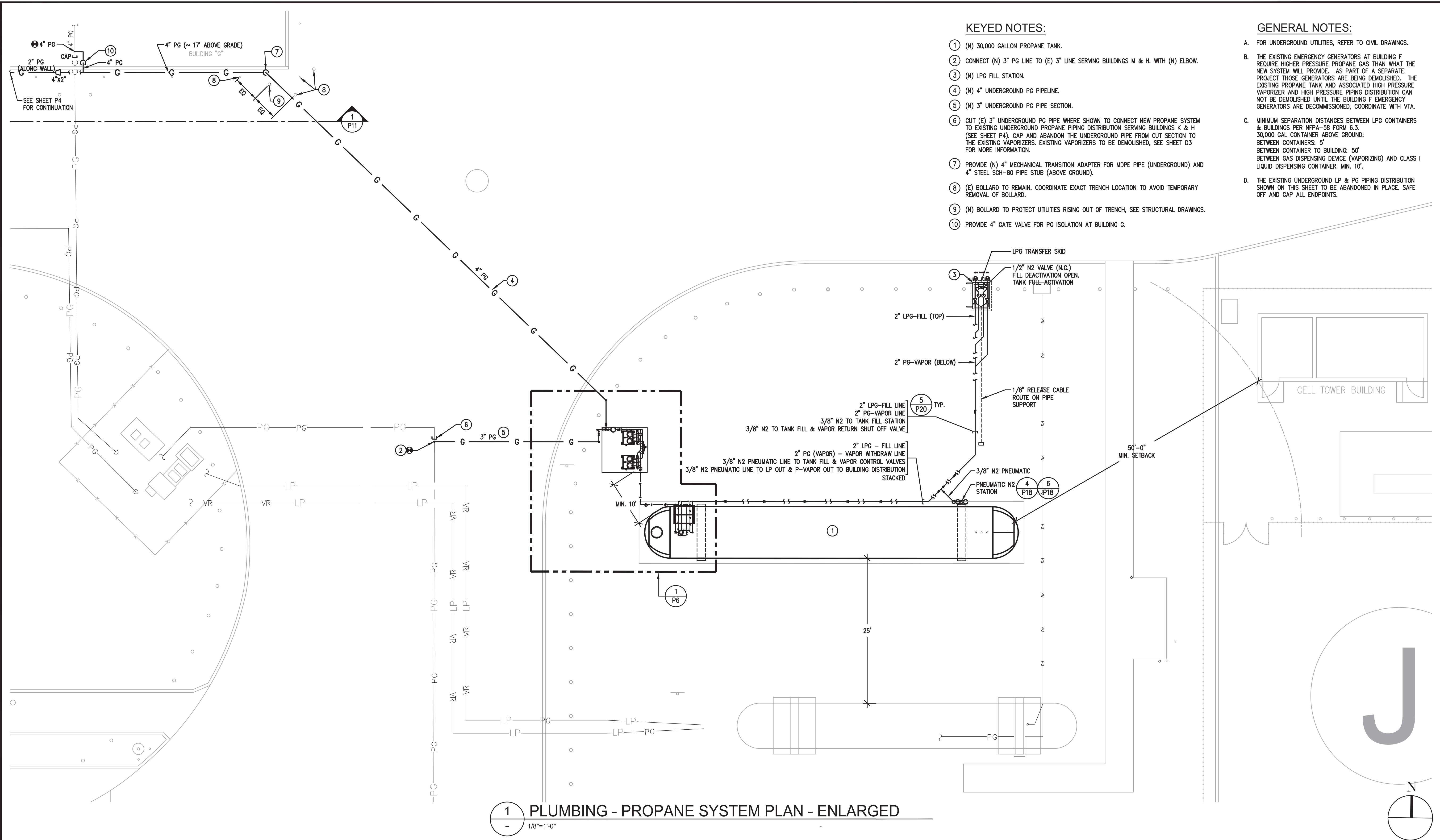

**KEYED NOTES:**

- ① (N) 30,000 GALLON PROPANE TANK.
- ② CONNECT (N) 3" PG LINE TO (E) 3" LINE SERVING BUILDINGS M & H. WITH (N) ELBOW.
- ③ (N) LPG FILL STATION.
- ④ (N) 4" UNDERGROUND PG PIPELINE.
- ⑤ (N) 3" UNDERGROUND PG PIPE SECTION.
- ⑥ CUT (E) 3" UNDERGROUND PG PIPE WHERE SHOWN TO CONNECT NEW PROPANE SYSTEM TO EXISTING UNDERGROUND PROPANE PIPING DISTRIBUTION SERVING BUILDINGS K & H (SEE SHEET P4). CAP AND ABANDON THE UNDERGROUND PIPE FROM CUT SECTION TO THE EXISTING VAPORIZERS. EXISTING VAPORIZERS TO BE DEMOLISHED, SEE SHEET D3 FOR MORE INFORMATION.
- ⑦ PROVIDE (N) 4" MECHANICAL TRANSITION ADAPTER FOR MDPE PIPE (UNDERGROUND) AND 4" STEEL SCH-80 PIPE STUB (ABOVE GROUND).
- ⑧ (E) BOLLARD TO REMAIN. COORDINATE EXACT TRENCH LOCATION TO AVOID TEMPORARY REMOVAL OF BOLLARD.
- ⑨ (N) BOLLARD TO PROTECT UTILITIES RISING OUT OF TRENCH, SEE STRUCTURAL DRAWINGS.
- ⑩ PROVIDE 4" GATE VALVE FOR PG ISOLATION AT BUILDING G.

**GENERAL NOTES:**

- A. FOR UNDERGROUND UTILITIES, REFER TO CIVIL DRAWINGS.
- B. THE EXISTING EMERGENCY GENERATORS AT BUILDING F REQUIRE HIGHER PRESSURE PROPANE GAS THAN WHAT THE NEW SYSTEM WILL PROVIDE. AS PART OF A SEPARATE PROJECT THOSE GENERATORS ARE BEING DEMOLISHED. THE EXISTING PROPANE TANK AND ASSOCIATED HIGH PRESSURE VAPORIZER AND HIGH PRESSURE PIPING DISTRIBUTION CAN NOT BE DEMOLISHED UNTIL THE BUILDING F EMERGENCY GENERATORS ARE DECOMMISSIONED, COORDINATE WITH VTA.
- C. MINIMUM SEPARATION DISTANCES BETWEEN LPG CONTAINERS & BUILDINGS PER NFPA-58 FORM 6.3. 30,000 GAL. CONTAINER ABOVE GROUND:  
 BETWEEN CONTAINERS: 5'  
 BETWEEN CONTAINER TO BUILDING: 50'  
 BETWEEN GAS DISPENSING DEVICE (VAPORIZING) AND CLASS I LIQUID DISPENSING CONTAINER: MIN. 10'.
- D. THE EXISTING UNDERGROUND LP & PG PIPING DISTRIBUTION SHOWN ON THIS SHEET TO BE ABANDONED IN PLACE. SAFE OFF AND CAP ALL ENDPNTS.

**1 PLUMBING - PROPANE SYSTEM PLAN - ENLARGED**  
 1/8"=1'-0"

NO.	DATE	REVISIONS
1	06/01/20	ISSUE FOR BID



<b>Integrated Engineering Services</b> 70 SARATOGA AVE. * SUITE 200 SANTA CLARA, CA. 95051-7301 PHONE: (408)261-3500 * FAX (408)261-4176 www.IEEngineering.net			
DESIGNED	TR	CHECKED	LC
DRAWN	HL	CADD FILE NAME	-



APPROVED	
CADD FILE DATE	SCALE
APRIL 15, 2020	AS NOTED
PLOT DATE	BOARD APPROVAL DATE
-	-

<b>CERONE DIVISION          BOILER AND PROPANE TANK          REPLACEMENT</b>			SHEET <b>17</b> OF 49 DRAWING NO. <b>P5</b> REVISION <b>1</b>
<b>PLUMBING          PROPANE SYSTEM PLAN - ENLARGED</b>			
BAP NO.	CONTRACT NO.	FILE LOCATION	
	C19123		

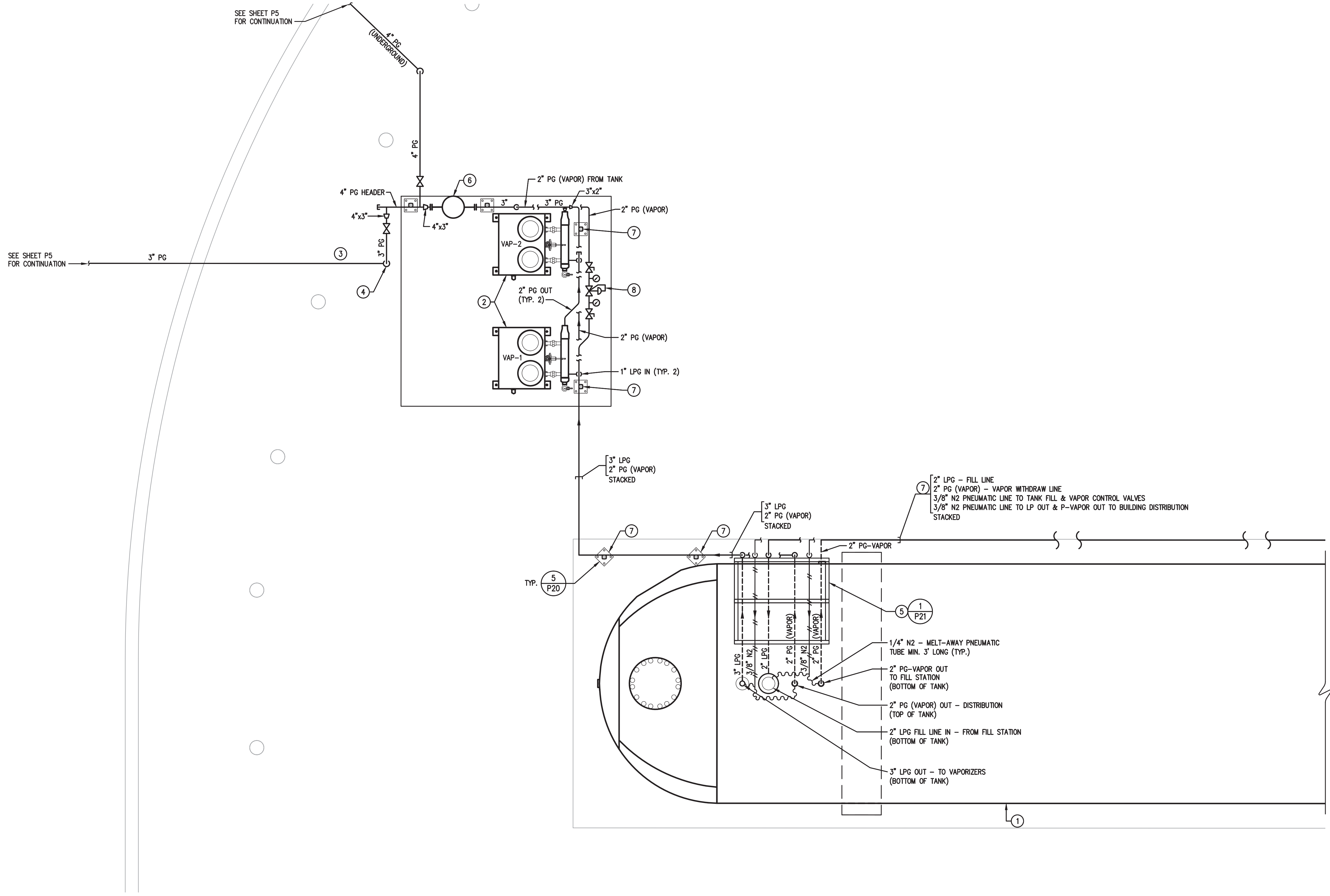

- GENERAL NOTES:**
- A. FOR UNDERGROUND UTILITIES, REFER TO CIVIL DRAWINGS.
  - B. THE EXISTING EMERGENCY GENERATORS AT BUILDING F REQUIRE HIGHER PRESSURE PROPANE GAS THAN WHAT THE NEW SYSTEM WILL PROVIDE. AS PART OF A SEPARATE PROJECT THOSE GENERATORS ARE BEING DEMOLISHED. THE EXISTING PROPANE TANK AND ASSOCIATED HIGH PRESSURE VAPORIZER AND HIGH PRESSURE PIPING DISTRIBUTION CAN NOT BE DEMOLISHED UNTIL THE BUILDING F EMERGENCY GENERATORS ARE DECOMMISSIONED, COORDINATE WITH VTA.

- KEYED NOTES:**
- ① (N) 30,000 GALLON PROPANE TANK. SEE STRUCTURAL DRAWINGS FOR INFORMATION RELATED TO CONCRETE FOOTINGS.
  - ② (N) PROPANE VAPORIZERS ON CONCRETE EQUIPMENT PAD. SEE STRUCTURAL FOR INFORMATION RELATED TO CONCRETE PAD. SEE ELECTRICAL FOR 110V IGNITION POWER.
  - ③ (N) 3" (UNDERGROUND) PG PIPE TO (E) LINE SERVING BLDG H & M.
  - ④ PROVIDE HDPE STEEL MECHANICAL JOINT ADAPTER ABOVE GROUND.
  - ⑤ PROVIDE (N) VERTICAL PIPE RACK FOR PIPING ROUTED TO TANK NOZZLES ON TOP & BOTTOM.
  - ⑥ INLINE SEPARATOR FOR PROPANE GAS MODEL: RANSOME IS310R.
  - ⑦ COMMUNICATION CONDUIT FOR FUTURE REMOTE MONITORING OF TANK LEVEL TO BE ROUTED ON SAME PIPE RACK, SEE ELECTRICAL DRAWINGS.
  - ⑧ LPG TANK VAPOR PRESSURE CONTROL STATION SET DOWNSTREAM PRESSURE @ 5 PSIG.

**1 PLUMBING - PROPANE SYSTEM PLAN - ENLARGED**  
1/2"=1'-0"

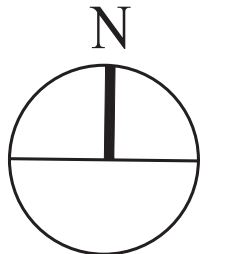

			<b>Integrated Engineering Services</b> 70 SARATOGA AVE. * SUITE 200 SANTA CLARA, CA. 95051-7301 PHONE: (408)261-3500 * FAX (408)261-4176 www.IEEngineering.net				<b>APPROVED</b> CADD FILE DATE: APRIL 15, 2020 SCALE: AS NOTED PLOT DATE: - BOARD APPROVAL DATE: -		<b>CERONE DIVISION BOILER AND PROPANE TANK REPLACEMENT</b>		SHEET 18 OF 49 DRAWING NO. P6 REVISION 1
DESIGNED	TR		CHECKED	LC	<b>PLUMBING PROPANE SYSTEM PLAN - ENLARGED</b>		BAP NO.	CONTRACT NO. C19123	FILE LOCATION		
NO.	DATE	REVISIONS		DRAWN	HL	CADD FILE NAME	-				
1	06/01/20	ISSUE FOR BID									



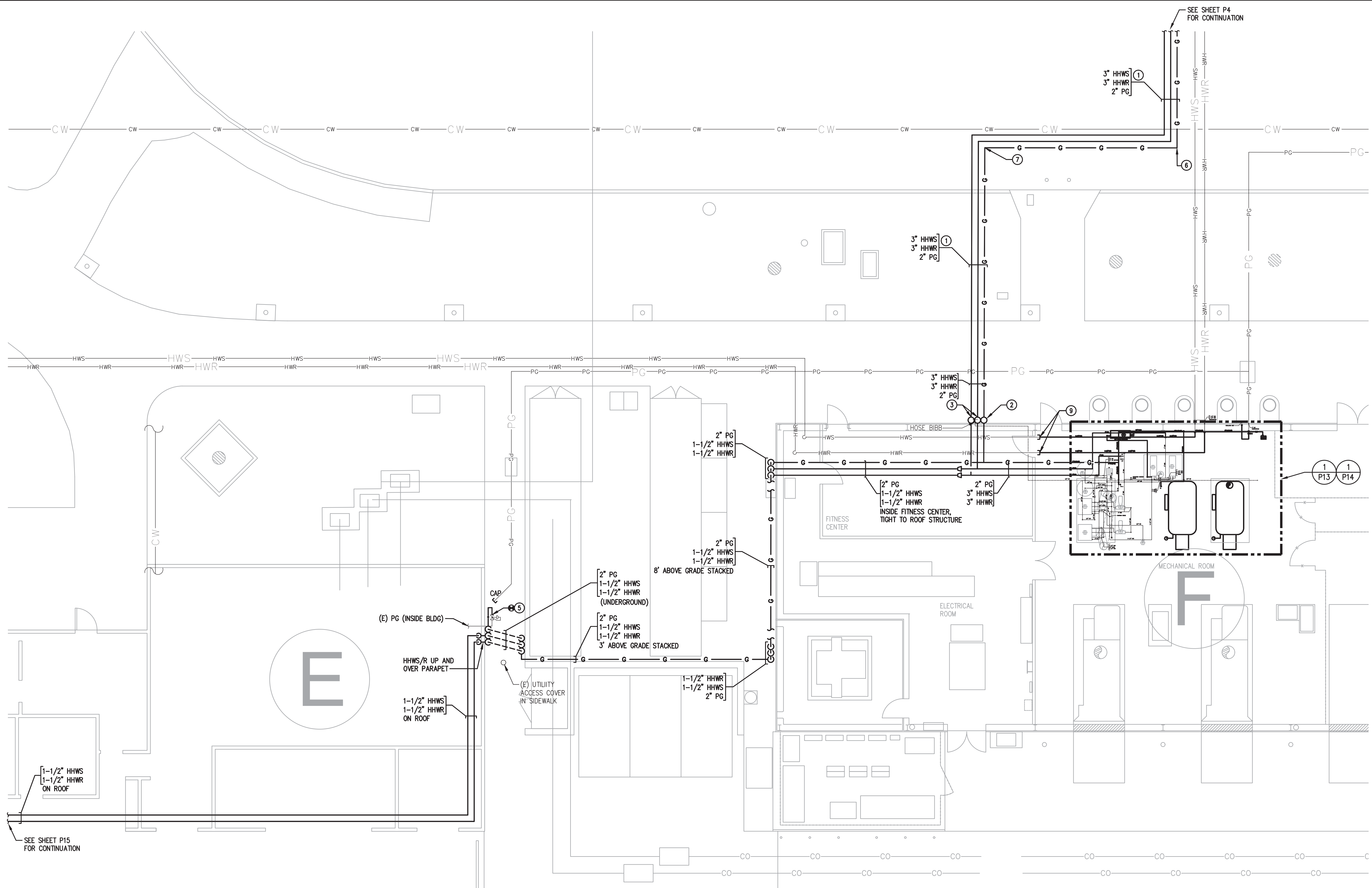

- GENERAL NOTES:**
- A. FOR UNDERGROUND UTILITIES, REFER TO CIVIL DRAWINGS.
  - B. THE EXISTING EMERGENCY GENERATORS AT BUILDING F REQUIRE HIGHER PRESSURE PROPANE GAS THAN WHAT THE NEW SYSTEM WILL PROVIDE. AS PART OF A SEPARATE PROJECT THOSE GENERATORS ARE BEING DEMOLISHED. THE EXISTING PROPANE TANK AND ASSOCIATED HIGH PRESSURE VAPORIZER AND HIGH PRESSURE PIPING DISTRIBUTION CAN NOT BE DEMOLISHED UNTIL THE BUILDING F EMERGENCY GENERATORS ARE DECOMMISSIONED, COORDINATE WITH VTA.
  - C. THE EXISTING UNDERGROUND HWS/R & PG PIPING DISTRIBUTION SHOWN ON THIS SHEET TO BE ABANDONED IN PLACE. SAFE OFF AND CAP ALL ENDPOINTS.
  - D. UTILITIES SHOWN TO BE DEMOLISHED IN THIS ROOM SHALL REMAIN IN PLACE AND IN SERVICE UNTIL ALL NEW UTILITIES ARE INSTALLED AND READY TO SWITCH OVER FOR STARTUP AND USE MOVING FORWARD.

- KEYED NOTES:**
- ① (N) 2" PG UNDERGROUND DISTRIBUTION BETWEEN BLDG G & F TO SERVE BLDG "F" AND "E". (N) 3" HHWS/R UNDERGROUND DISTRIBUTION TO/FROM BLDG F TO SERVE BLDG "G".
  - ② PROVIDE (N) 2" MECHANICAL TRANSITION ADAPTER FOR MDPE PG PIPE (UNDERGROUND) AND 2" STEEL SCH-80 PIPE STUB (ABOVE GROUND). INSTALL 2" GATE VALVE.
  - ③ HHWS/R RISER AT BLDG F.
  - ④ PROVIDE 2" MECHANICAL TRANSITION ADAPTER FOR 2" MDPE PIPE (UNDERGROUND) AND 2" SCH-80 STEEL PIPE (ABOVE GROUND).
  - ⑤ ROUTE 2" SCH-80 PIPE ON WALL AND CONNECT TO (E) PRESSURE REGULATOR INLET.
  - ⑥ INSTALL (N) 2" HDPE ELECTROFUSION ELBOW IN UNDER GROUND PG LINE.
  - ⑦ INSTALL (N) 2" HDPE ELECTROFUSION TEE.
  - ⑧ CUT & PLUG (E) 2" PG LINE ABOVE CONCRETE SURFACE.
  - ⑨ DEMO AND CAP ABANDONED HWS/R LINES WITHIN BUILDING F MECHANICAL ROOM AS SHOWN.

**1 PLUMBING - UNDERGROUND BLDG. F PLAN**  
 1/8"=1'-0"

NO.	DATE	REVISIONS
1	06/01/20	ISSUE FOR BID

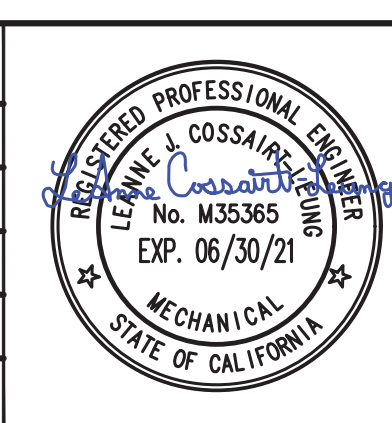

**Integrated Engineering Services**  
 70 SARATOGA AVE. SUITE 200  
 SANTA CLARA, CA. 95051-7301  
 PHONE: (408)261-3500 \* FAX (408)261-4176  
 www.IESengineering.net

DESIGNED: TR      CHECKED: LC  
 DRAWN: HL      CADD FILE NAME: -



APPROVED	
CADD FILE DATE APRIL 15, 2020	SCALE AS NOTED
PLT DATE -	BOARD APPROVAL DATE -

<b>CERONE DIVISION BOILER AND PROPANE TANK REPLACEMENT</b>			SHEET <b>19</b> OF 49 DRAWING NO. <b>P7</b>
<b>PLUMBING UNDERGROUND BLDG. F PLAN</b>			
SAP NO.	CONTRACT NO. C19123	FILE LOCATION	REVISION 1



LPG SYSTEM PIPING SYMBOLS

SYMBOL	ABBREV	DESCRIPTION
	BV	BALL VALVE
	GV	GATE VALVE
	PV	PLUG VALVE
	GLV	GLOBE VALVE
	NV	NEEDLE VALVE
	DV	DIAPHRAGM VALVE
	PRV	PRESSURE RELIEF VALVE
	HPRV	HYDROSTATIC RELIEF VALVE
	ILTV/IVTV	INTERNAL LIQUID/VAPOR TRANSFER VALVE WITH PNEUMATIC ACTUATOR WITH 1/4" MELT-AWAY PNEUMATIC TUBING. (TYP.)
	ILTV/IVTV	INTERNAL LIQUID/VAPOR TRANSFER VALVE WITH ELECTRIC ACTUATOR
	ILTV/IVTV	INTERNAL LIQUID/VAPOR TRANSFER VALVE WITH MANUAL ACTUATOR
	LPV/VPAV	LIQUID/VAPOR PULL-AWAY VALVE FOR HOSE TRANSFER
	LESV/VESV	LIQUID/VAPOR EMERGENCY SHUTOFF VALVE WITH MELT-AWAY PNEUMATIC TUBING
	ESV-CL	LIQUID/VAPOR EMERGENCY SHUTOFF - VALVE CABLE LATCH & INTEGRAL FUSIBLE ELEMENT
	ESV-PL	LIQUID/VAPOR EMERGENCY SHUTOFF - VALVE PNEUMATIC LATCH & INTEGRAL FUSIBLE ELEMENT
	SV	TWO WAY ELECTRIC SOLENOID CONTROL VALVE
		Y-TYPE STRAINER
		FLEXIBLE PIPE CONNECTION
		PIPE CAP
		PNEUMATIC PIPING (COPPER)
		INSULATED PIPE
		FLANGE ASSEMBLY
		UNION
		RUPTURE DISK
	PG	ROTARY GAUGE LEVEL INDICATOR
	PG	PRESSURE GAUGE
	PT	PRESSURE TRANSMITTER EXPLOSION/FRAME PROOF
	TG	THERMOMETER
	BPRV	PRESSURE RETAINING VALVE OR BACK PRESSURE REGULATING VALVE
	PRV	PRESSURE REGULATING VALVE

COMPONENT ID SYMBOLS

SYMBOL	DESCRIPTION
	<b>PROPANE TRANSFER SYSTEM</b> COMPONENT IDENTIFICATION - NAME/TYPE NUMBER HV1 - HOSE VALVE/TYP 1 IV1 - ISOLATION VALVE/TYP 1 (LIQUID LINE) IV2 - ISOLATION VALVE/TYP 1 (VAPOR LINE) ES1 - EMERGENCY SHUT-OFF VALVE/TYP 1 ES2 - EMERGENCY SHUT-OFF VALVE/TYP 1 TCV - PNEUMATIC SYSTEM CHARGE VALVE TEV - PNEUMATIC ACTUATOR EMERGENCY SHUTOFF VALVE FI1 - FLOW INDICATOR/TYP 1 EQ1 - PNEUMATIC NITROGEN SOURCE DISTRIBUTION PANEL
	<b>PROPANE STORAGE TANK</b> COMPONENT IDENTIFICATION - NAME/TYP NUMBER IV1 - ISOLATION VALVE/TYP 1 (2") IV1B - ISOLATION VALVE/TYP 2 (3") IV2 - INTERNAL VAPOR RETURN VALVE WITH ACTUATOR IV3 - INTERNAL LIQUID FILL VALVE WITH ACTUATOR IV4 - INTERNAL VAPOR TRANSFER (SUPPLY) VALVE WITH ACTUATOR IV5 - INTERNAL LIQUID SUPPLY VALVE WITH ACTUATOR RV1 - PRESSURE RELIEF VALVE - LPG TANK OVER PR. RELIEF RV2 - HYDROSTATIC RELIEF VALVE - LPG PIPE OVER PR. RELIEF LI1 - ROTARY GAUGE LEVEL INDICATOR - LPG TANK LEVEL INDICATION LM1 - TANK FLOAT GAUGE LIQUID LEVEL MONITORING SYSTEM LM2 - ULTRASONIC LEVEL MONITORING SYSTEM FC1 - FLEX PIPE CONNECTOR/TYP-1 SV1 - LOW VOLTAGE SOLENOID VALVE
	<b>PROPANE DISTRIBUTION SYSTEM</b> COMPONENT IDENTIFICATION - NAME/TYP NUMBER PR1 - PRESSURE REGULATOR - LPG TANK PR. CONTROL PR2 - PRESSURE REGULATOR - PROPANE SUPPLY PR. CONTROL RV1 - PRESSURE RELIEF VALVE - PG DISTRIBUTION PIPING PR. RELIEF RV2 - HYDROSTATIC RELIEF VALVE - LPG PIPE OVER PR. RELIEF ES1 - EMERGENCY SHUT-OFF VALVE - VAPORIZER LIQUID SUPPLY ST1 - STRAINER - VAPORIZERS LPG SUPPLY LINE IV1 - ISOLATION VALVE (LINE SIZE 2", 3", & 4") EQ1 - SEPARATOR - MAIN PROPANE GAS SERVICE LINE PG1 - PRESSURE GAUGE (0-30 PSIG)

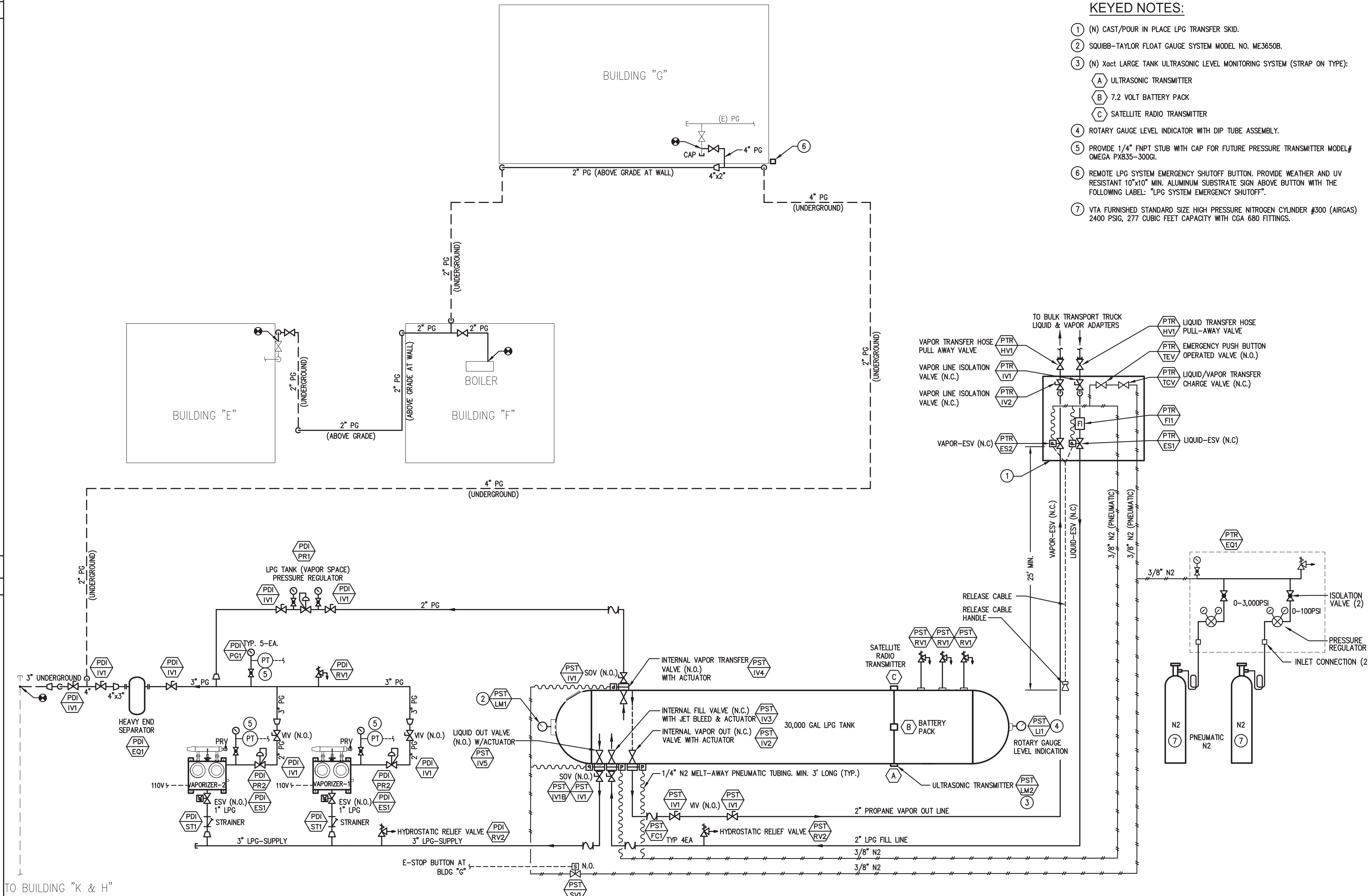

- KEYED NOTES:**
- (N) CAST/POUR IN PLACE LPG TRANSFER SKID.
  - SQUIBB-TAYLOR FLOAT GAUGE SYSTEM MODEL NO. ME3650B.
  - (N) Xact LARGE TANK ULTRASONIC LEVEL MONITORING SYSTEM (STRAP ON TYPE):
    - A ULTRASONIC TRANSMITTER
    - B 7.2 VOLT BATTERY PACK
    - C SATELLITE RADIO TRANSMITTER
  - ROTARY GAUGE LEVEL INDICATOR WITH DIP TUBE ASSEMBLY.
  - PROVIDE 1/4" FNPT STUB WITH CAP FOR FUTURE PRESSURE TRANSMITTER MODEL# OMEGA PX835-300G.
  - REMOTE LPG SYSTEM EMERGENCY SHUTOFF BUTTON. PROVIDE WEATHER AND UV RESISTANT 10"x10" MIN. ALUMINUM SUBSTRATE SIGN ABOVE BUTTON WITH THE FOLLOWING LABEL: "LPG SYSTEM EMERGENCY SHUTOFF".
  - VTA FURNISHED STANDARD SIZE HIGH PRESSURE NITROGEN CYLINDER #300 (AIRGAS) 2400 PSIG, 277 CUBIC FEET CAPACITY WITH CGA 680 FITTINGS.

1 PLUMBING - LIQUID & GASEOUS PROPANE STORAGE AND DISTRIBUTION SYSTEM - P&ID

	SUBMITTED  Integrated Engineering Services 70 SARATOGA AVE. * SUITE 200 SANTA CLARA, CA 95051-7301 PHONE: (408)261-3500 * FAX (408)261-4176 www.IEEngineering.net	 Santa Clara Valley Transportation Authority	APPROVED CADD FILE DATE: APRIL 15, 2020 PLOT DATE: -	SCALE: NONE BOARD APPROVAL DATE: -	CERONE DIVISION BOILER AND PROPANE TANK REPLACEMENT PLUMBING LIQUID & GASEOUS PROPANE STORAGE & DIST. SYSTEM - P&ID	SHEET 20 OF 49 DRAWING NO. P8 REVISION 1
	DESIGNED: TR CHECKED: LC DRAWN: HL CADD FILE NAME: -		BAP NO. * CONTRACT NO. C19123 FILE LOCATION: -			



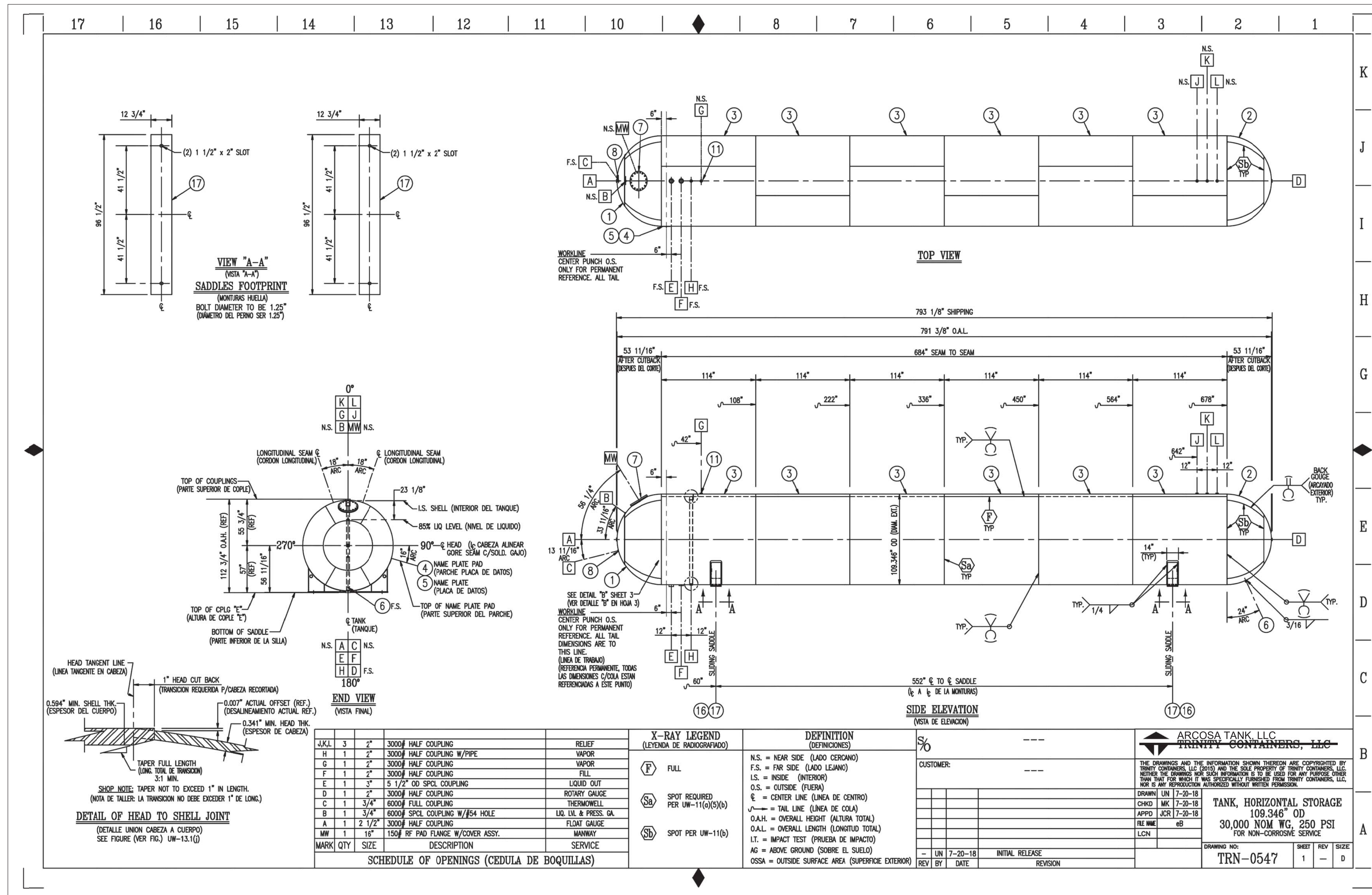

**NOTES:**

- REFERENCES TO MANUFACTURER'S NAME AND MODEL NUMBER ARE USED TO ESTABLISH A QUALITY STANDARD FOR THIS PROJECT. IT IS UNDERSTOOD THAT SUCH REFERENCES ARE USED TO FACILITATE THE DESCRIPTION OF THE PRODUCT AND IS DEEMED TO BE FOLLOWED BY THE WORDS "OR EQUAL".
- ARCOSA TANK, LLC RECENTLY ACQUIRED TRINITY CONTAINERS, LLC. THIS IS THE NAME CHANGE. THE TANK SPECIFICATIONS DO NOT CHANGE AS A RESULT OF THIS NAME CHANGE.

**1 PLUMBING - LPG TANK DETAILS**

		<p>Integrated Engineering Services 70 SARATOGA AVE. SUITE 200 SANTA CLARA, CA. 95051-7301 PHONE: (408)261-3500 * FAX (408)261-4176 www.IESengineering.net</p>		<p>Santa Clara Valley Transportation Authority</p>		<p>CERONE DIVISION BOILER AND PROPANE TANK REPLACEMENT PLUMBING PROPANE TANK DETAILS</p>		<p>SHEET 21 OF 49 DRAWING NO. P9 REVISION 1</p>
DESIGNED	TR	CHECKED	LC	CADD FILE DATE	APRIL 15, 2020	SCALE	NONE	<p>SAP NO. CONTRACT NO. C19123 FILE LOCATION</p>
DRAWN	HL	CADD FILE NAME	-	PLOT DATE	-	BOARD APPROVAL DATE	-	



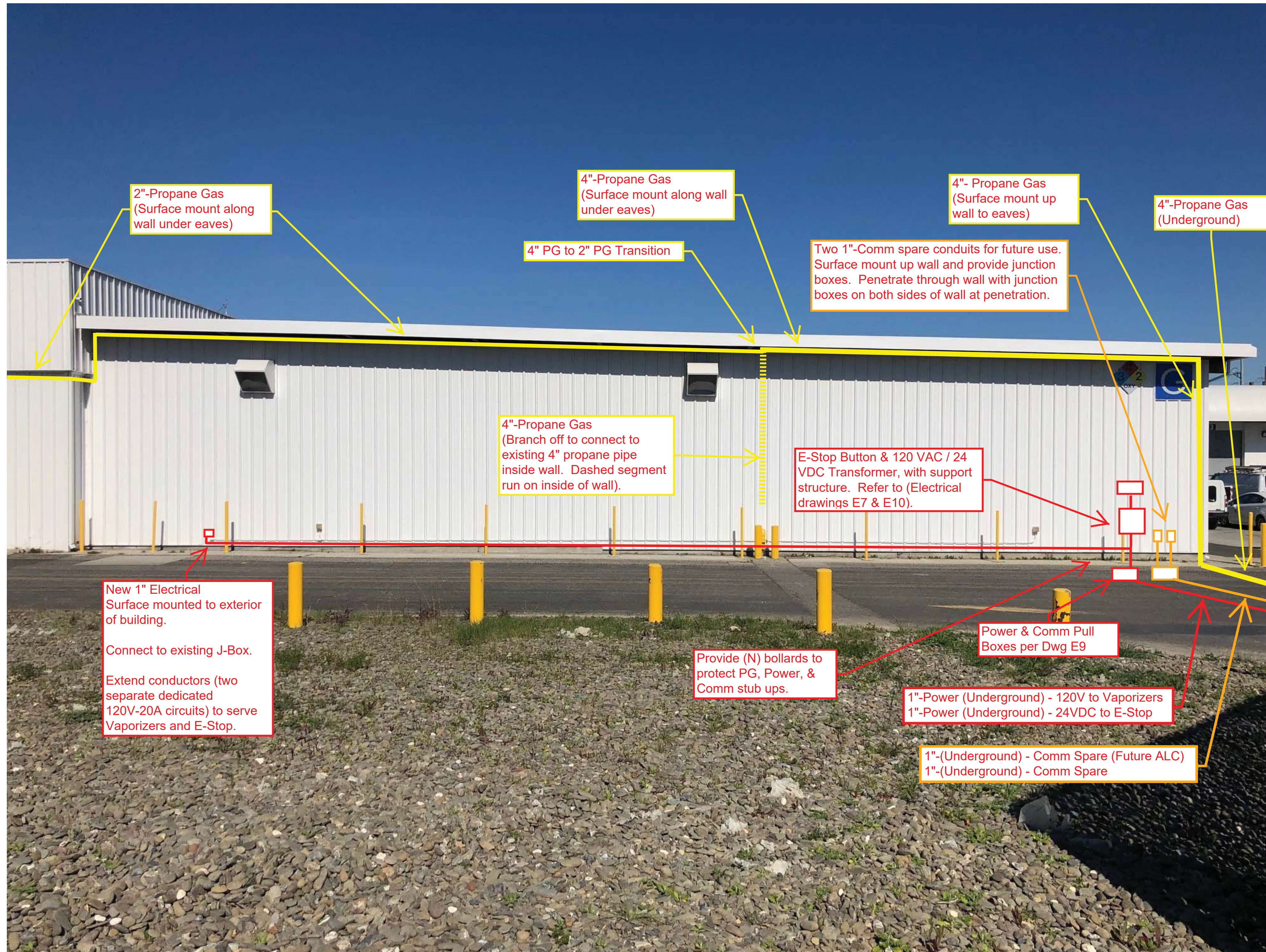

1 PLUMBING - BLDG G - UTILITY ROUTING  
- NTS

				<b>Integrated Engineering Services</b> 70 SARATOGA AVE. * SUITE 200 SANTA CLARA, CA. 95051-7301 PHONE: (408)261-3500 * FAX (408)261-4176 www.IEEngineering.net				APPROVED  CADD FILE DATE: APRIL 15, 2020 PLOT DATE: - SCALE: AS NOTED BOARD APPROVAL DATE: -		CERONE DIVISION BOILER AND PROPANE TANK REPLACEMENT PLUMBING BLDG G - UTILITY ROUTING		SHEET 22 OF 49 DRAWING NO. P10 REVISION 1
1	06/01/20	ISSUE FOR BID		DESIGNED	TR	CHECKED	LC	SAP NO.		CONTRACT NO. C19123		FILE LOCATION
NO.	DATE	REVISIONS		DRAWN	HL	CADD FILE NAME						



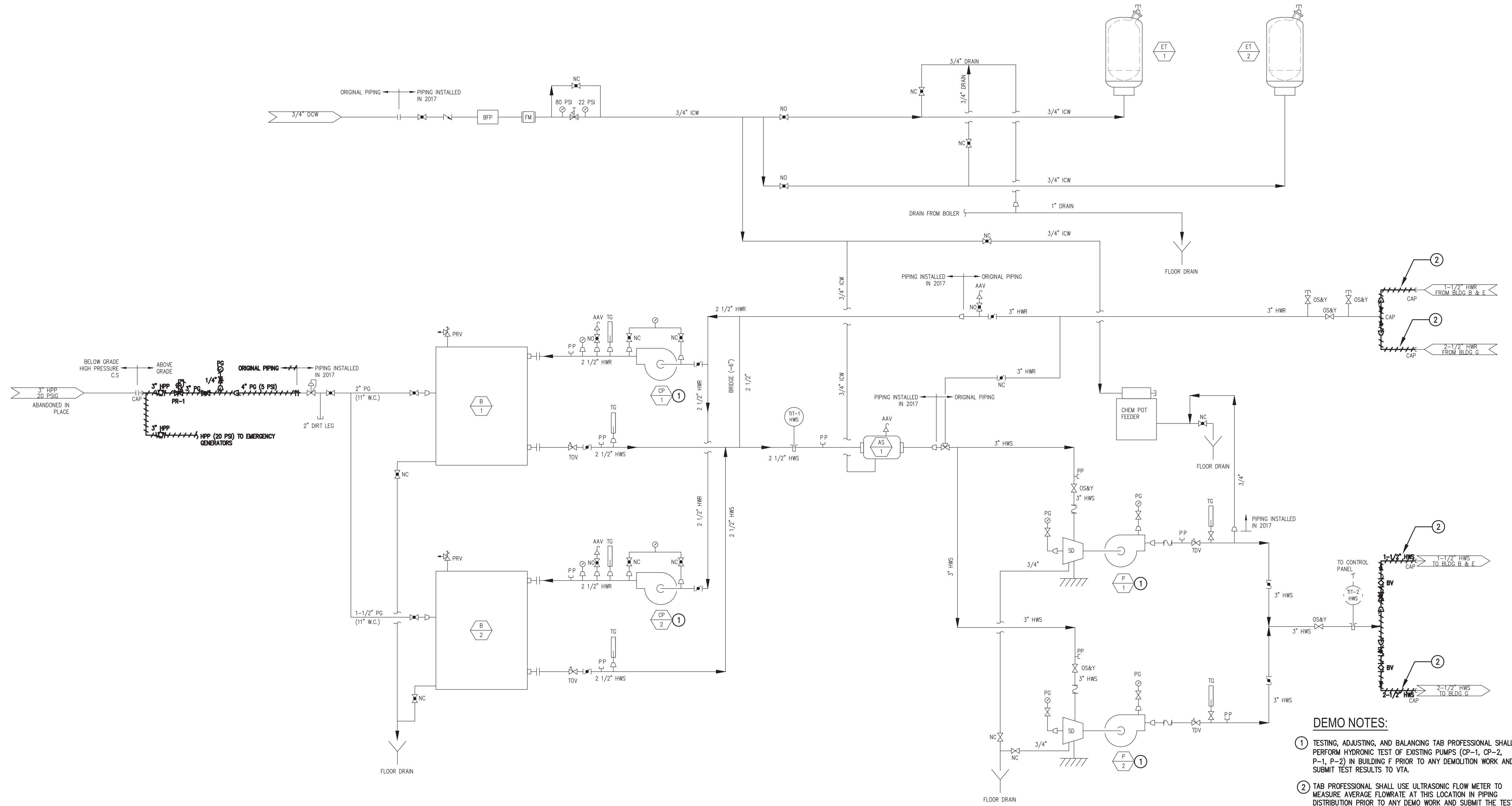

- DEMO NOTES:**
- ① TESTING, ADJUSTING, AND BALANCING TAB PROFESSIONAL SHALL PERFORM HYDRONIC TEST OF EXISTING PUMPS (CP-1, CP-2, P-1, P-2) IN BUILDING F PRIOR TO ANY DEMOLITION WORK AND SUBMIT TEST RESULTS TO VTA.
  - ② TAB PROFESSIONAL SHALL USE ULTRASONIC FLOW METER TO MEASURE AVERAGE FLOWRATE AT THIS LOCATION IN PIPING DISTRIBUTION PRIOR TO ANY DEMO WORK AND SUBMIT THE TEST REPORT TO VTA.

**1 PLUMBING - BUILDING F - HEATING HOT WATER SYSTEM - P&ID DEMO**  
- NTS

NO.	DATE	REVISIONS
1	06/01/20	ISSUE FOR BID



<b>Integrated Engineering Services</b> 70 SARATOGA AVE. * SUITE 200 SANTA CLARA, CA. 95051-7301 PHONE: (408)261-3500 * FAX (408)261-4176 www.IEEngineering.net			
DESIGNED	TR	CHECKED	LC
DRAWN	HL	CADD FILE NAME	-



APPROVED	
CADD FILE DATE	SCALE
APRIL 15, 2020	NONE
PLOT DATE	BOARD APPROVAL DATE
-	-

<b>CERONE DIVISION BOILER AND PROPANE TANK REPLACEMENT</b>			SHEET 23 OF 49 DRAWING NO. P11 REVISION 1
<b>PLUMBING BLDG F - HEATING HOT WATER SYSTEM - P&amp;ID DEMO</b>			
BAP NO.	CONTRACT NO.	FILE LOCATION	
*	C19123		

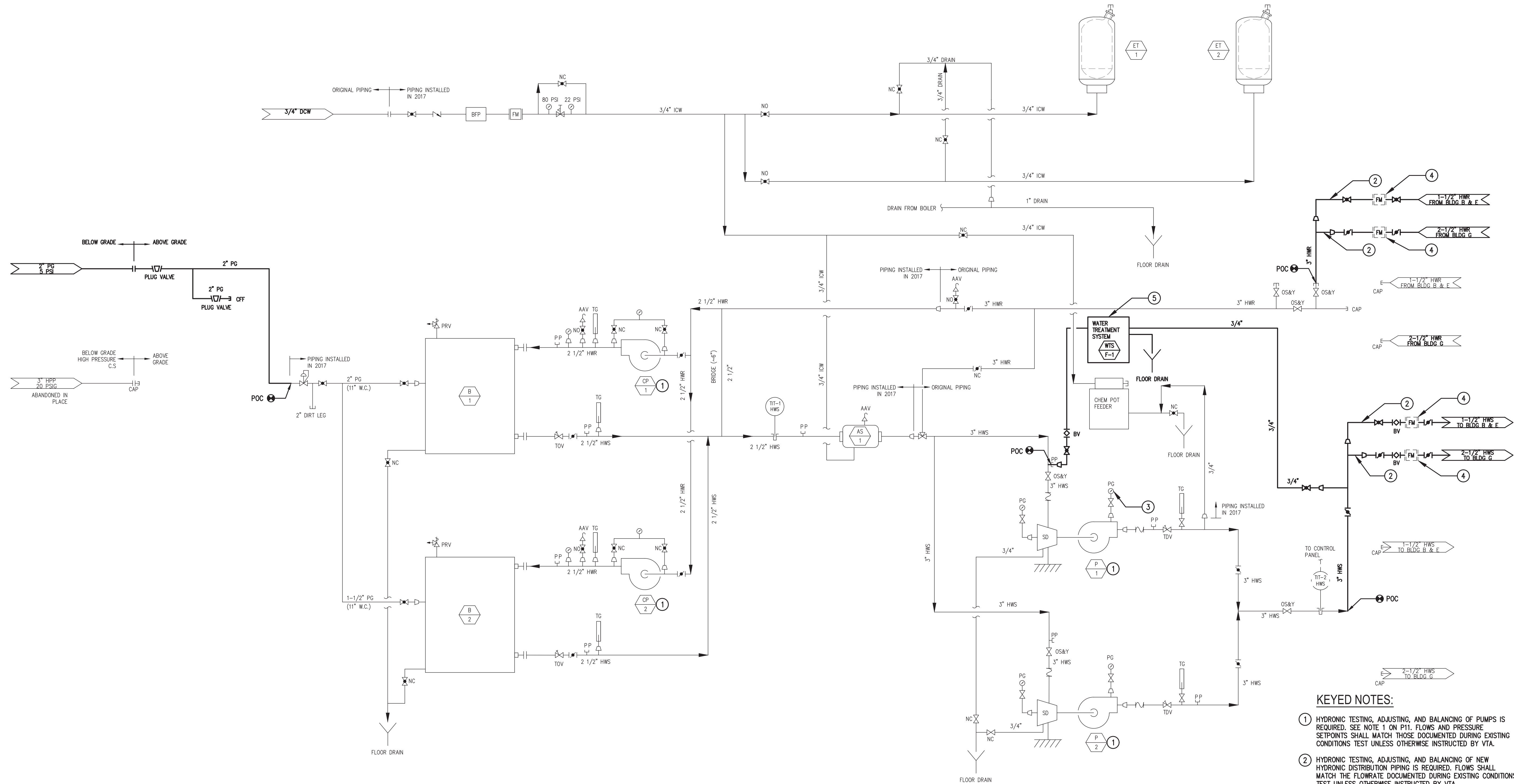

- KEYED NOTES:**
- ① HYDRONIC TESTING, ADJUSTING, AND BALANCING OF PUMPS IS REQUIRED. SEE NOTE 1 ON P11. FLOWS AND PRESSURE SETPOINTS SHALL MATCH THOSE DOCUMENTED DURING EXISTING CONDITIONS TEST UNLESS OTHERWISE INSTRUCTED BY VTA.
  - ② HYDRONIC TESTING, ADJUSTING, AND BALANCING OF NEW HYDRONIC DISTRIBUTION PIPING IS REQUIRED. FLOWS SHALL MATCH THE FLOWRATE DOCUMENTED DURING EXISTING CONDITIONS TEST UNLESS OTHERWISE INSTRUCTED BY VTA.
  - ③ GAUGE MISSING. REPLACE GAUGE.
  - ④ ALLOW SPACE IN PIPING FOR INSTALLATION OF FUTURE FLOW METER (MINIMUM OF 20 PIPE DIAMETERS OF LENGTH).
  - ⑤ PROVIDE NEW WATER TREATMENT SYSTEM (SEE P21).

**1 PLUMBING - BUILDING F - HEATING HOT WATER SYSTEM - P&ID - PROPOSED**  
- NTS

NO.	DATE	REVISIONS
1	06/01/20	ISSUE FOR BID



**Integrated Engineering Services**  
70 SARATOGA AVE. \* SUITE 200  
SANTA CLARA, CA. 95051-7301  
PHONE: (408)261-3500 \* FAX (408)261-4176  
www.IEEngineering.net

DESIGNED	TR	CHECKED	LC
DRAWN	HL	CADD FILE NAME	-



**APPROVED**

CADD FILE DATE	APRIL 15, 2020	SCALE	NONE
PLOT DATE	-	BOARD APPROVAL DATE	-

**CERONE DIVISION  
BOILER AND PROPANE TANK  
REPLACEMENT**

PLUMBING  
BLDG F - HEATING HOT WATER SYSTEM - P&ID - PROPOSED

SHEET	24
OF 49	
DRAWING NO.	P12
REVISION	1

BAP NO.	*	CONTRACT NO.	C19123	FILE LOCATION	
---------	---	--------------	--------	---------------	--



**GENERAL NOTES:**

- A. FOR UNDERGROUND UTILITIES, REFER TO CIVIL DRAWINGS.
- B. THE EXISTING EMERGENCY GENERATORS AT BUILDING F REQUIRE HIGHER PRESSURE PROPANE GAS THAN WHAT THE NEW SYSTEM WILL PROVIDE. AS PART OF A SEPARATE PROJECT THOSE GENERATORS ARE BEING DEMOLISHED. THE EXISTING PROPANE TANK AND ASSOCIATED HIGH PRESSURE VAPORIZER AND HIGH PRESSURE PIPING DISTRIBUTION CAN NOT BE DEMOLISHED UNTIL THE BUILDING F EMERGENCY GENERATORS ARE DECOMMISSIONED, COORDINATE WITH VTA.
- C. THE EXISTING UNDERGROUND HWS/R & PG PIPING DISTRIBUTION SHOWN ON THIS SHEET TO BE ABANDONED IN PLACE. SAFE OFF AND CAP ALL ENDSPOINTS.
- D. UTILITIES SHOWN TO BE DEMOLISHED IN THIS ROOM SHALL REMAIN IN PLACE AND IN SERVICE UNTIL ALL NEW UTILITIES ARE INSTALLED AND READY TO SWITCH OVER FOR STARTUP AND USE MOVING FORWARD.

**DEMO NOTES:**

- ① ABANDONED BOILERS TO BE DEMOLISHED. SEE SHEET D1.
- ② DEMOLISH PROPANE GAS LINE SERVING BOILERS B-1 AND B-2.
- ③ DEMOLISH ABANDONED HIGH PRESSURE PROPANE LINE TO ABANDONED GENERATORS (SEE GENERAL NOTE B, AND SEE SHEETS D1 AND D2).
- ④ DEMOLISH 2-1/2" HEATING HOT WATER SUPPLY LINE FROM TEE IN MAIN OVER TO THE RISER, CAP ABANDONED LINE AT 6" ABOVE FLOOR. LABEL THE CAP "ABANDONED 2-1/2" HWS TO BUILDING 6."
- ⑤ DEMOLISH 2-1/2" HEATING HOT WATER RETURN LINE FROM TEE IN MAIN OVER TO THE RISER, CAP ABANDONED LINE AT 6" ABOVE FLOOR. LABEL THE CAP "ABANDONED 2-1/2" HWR TO BUILDING 6."
- ⑥ DEMOLISH 1-1/2" HEATING HOT WATER SUPPLY LINE FROM TEE TO MECHANICAL ROOM WALL AND CAP, SEE SHEET P7.
- ⑦ DEMOLISH 1-1/2" HEATING HOT WATER RETURN LINE FROM TEE TO MECHANICAL ROOM WALL AND CAP, SEE SHEET P7.

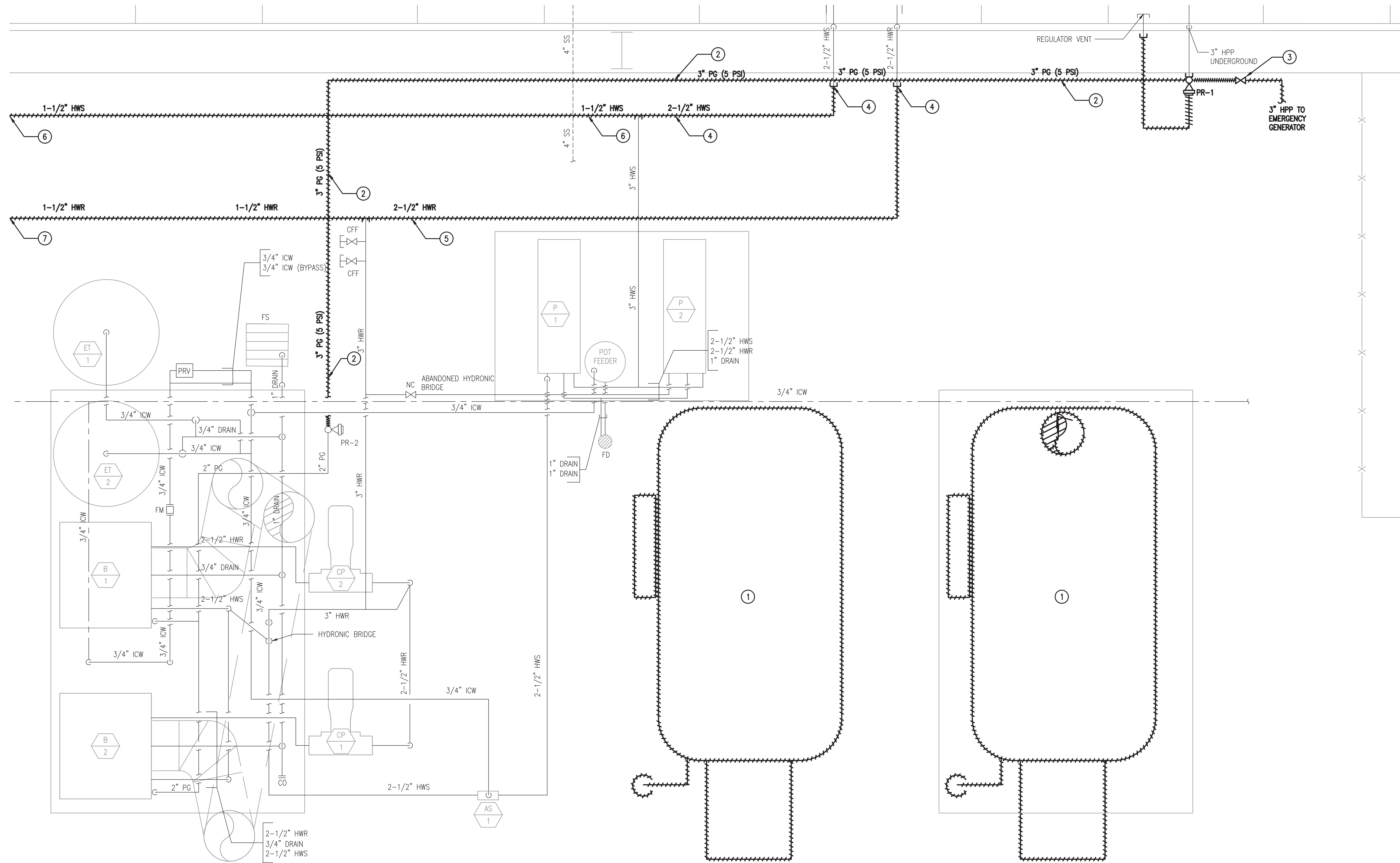

1 PLUMBING - BUILDING F - CENTRAL UTILITIES BUILDING - DEMO PLAN  
3/4"=1'-0"

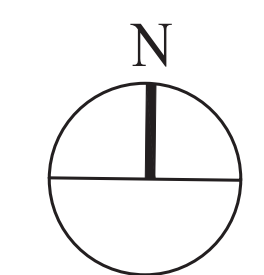

				SUBMITTED  Integrated Engineering Services 70 SARATOGA AVE. SUITE 200 SANTA CLARA, CA. 95051-7301 PHONE: (408)261-3500 * FAX (408)261-4176 www.IESengineering.net		APPROVED  CADD FILE DATE: APRIL 15, 2020 SCALE: AS NOTED PLOT DATE: - BOARD APPROVAL DATE: -		CERONE DIVISION BOILER AND PROPANE TANK REPLACEMENT PLUMBING BLDG F - CENTRAL UTILITIES BUILDING - DEMO PLAN		SHEET OF 49 DRAWING NO. P13 REVISION 1
1	06/01/20	ISSUE FOR BID		DESIGNED	TR	CHECKED	LC	SAP NO.	CONTRACT NO.	FILE LOCATION
NO.	DATE	REVISIONS		DRAWN	HL	CADD FILE NAME	-	C19123	-	-



**KEYED NOTES:**

- ① WALL MOUNT WATER TREATMENT SYSTEM
- ② CONNECT WATER TREATMENT TO PUMP SUCTION.
- ③ CONNECT WATER TREATMENT SUPPLY TO PUMP HWS DISCHARGE.

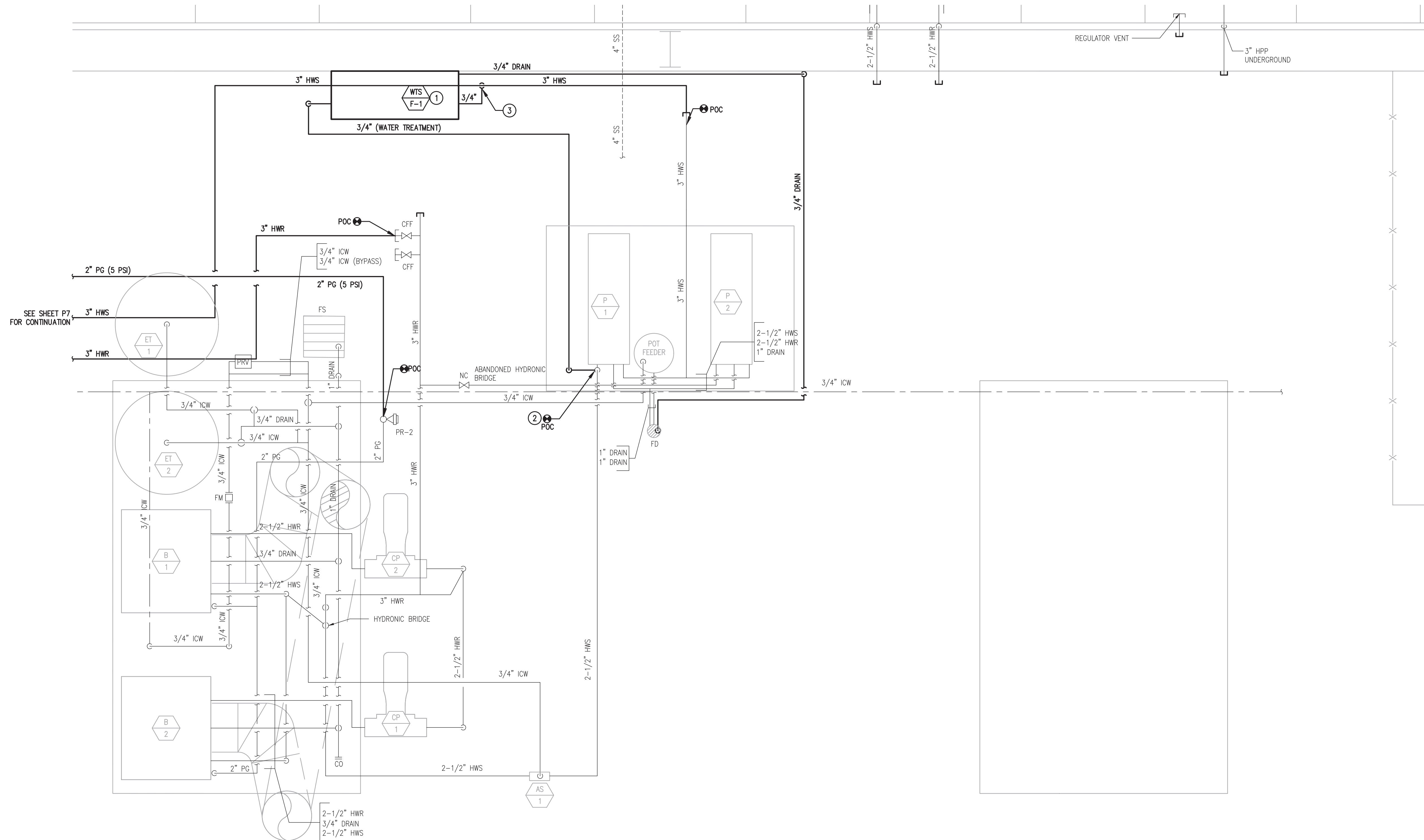

**1 PLUMBING - BUILDING F - CENTRAL UTILITIES BUILDING - PROPOSED PLAN**  
 - 3/4"=1'-0"

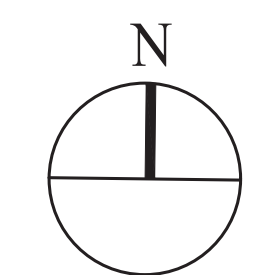

NO.	DATE	REVISIONS
1	06/01/20	ISSUE FOR BID



SUBMITTED		 Integrated Engineering Services 70 SARATOGA AVE. • SUITE 200 SANTA CLARA, CA. 95051-7301 PHONE: (408)261-3500 * FAX (408)261-4176 www.IESengineering.net	
DESIGNED	TR	CHECKED	LC
DRAWN	HL	CADD FILE NAME	-



APPROVED	
CADD FILE DATE	SCALE
APRIL 15, 2020	AS NOTED
PLOT DATE	BOARD APPROVAL DATE
-	-

CERONE DIVISION BOILER AND PROPANE TANK REPLACEMENT PLUMBING BLDG F - CENTRAL UTILITIES BUILDING - PROPOSED PLAN		
SAP NO.	CONTRACT NO.	FILE LOCATION
	C19123	

SHEET	26
OF 49	
DRAWING NO.	P14
REVISION	1



**GENERAL NOTES:**

- A. FOR UNDERGROUND UTILITIES, REFER TO CIVIL DRAWINGS.
- B. DEMOLITION OF THE EXISTING PROPANE SYSTEM SHALL BE PHASED TO PROVIDE CONTINUOUS SERVICE TO THE EMERGENCY POWER GENERATORS IN BUILDING F.
- C. THE EXISTING UNDERGROUND HWS/R PIPING DISTRIBUTION SHOWN ON THIS SHEET TO BE ABANDONED IN PLACE. SAFE OFF AND CAP ALL ENDPOINTS.

**KEYED NOTES:**

- ① BLDG "B" 1-1/2" HHWS/R SERVICE CONNECTION POINTS.
- ② 1-1/2" HHWS/R DOWN THROUGH ROOF TO BLDG "E" HHWS/R SERVICE CONNECTION POINTS.
- ③ INSTALL (N) 3/4" ICW & CONNECT TO (E) 2" DCW.
- ④ (N) 2" PG. RUN ALONG WALL AT 10' MIN. ABOVE GROUND.

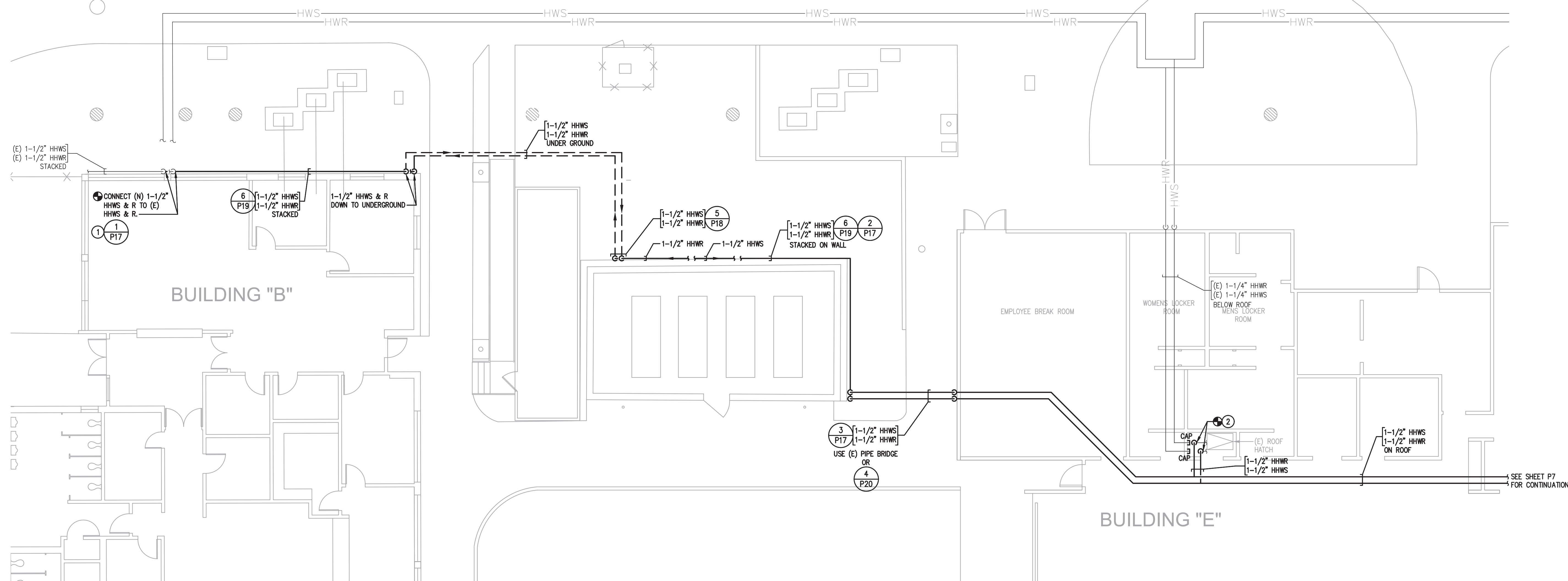

**1 PLUMBING - BUILDING B&E NEW HHW PIPING PLAN**  
 - 1/8"=1'-0"

NO.	DATE	REVISIONS
1	06/01/20	ISSUE FOR BID



SUBMITTED Integrated Engineering Services 70 SARATOGA AVE. * SUITE 200 SANTA CLARA, CA. 95051-7301 PHONE: (408)261-3500 * FAX (408)261-4176 www.IEEngineering.net			
DESIGNED	TR	CHECKED	LC
DRAWN	HL	CADD FILE NAME	-



APPROVED	
CADD FILE DATE	SCALE
APRIL 15, 2020	AS NOTED
PLOT DATE	BOARD APPROVAL DATE
-	-

CERONE DIVISION BOILER AND PROPANE TANK REPLACEMENT PLUMBING BUILDING B + E - NEW HHW PIPING PLAN		
SAP NO.	CONTRACT NO.	FILE LOCATION
	C19123	

SHEET	27
OF 49	
DRAWING NO.	P15
REVISION	1





5 HHW & ICW PIPE ROUTING AT BLDG E  
- NTS

3 HHW & ICW PIPE ROUTING TO BLDG E  
- NTS

1 HHW PIPE ROUTING TO BLDG-B  
- NTS



4 HHW & ICW PIPE ROUTING AT BLDG E  
- NTS

2 HHW PIPE ROUTING BOILER PAD TO BLDG E  
- NTS

NO.	DATE	REVISIONS
1	06/01/20	ISSUE FOR BID



SUBMITTED		 Integrated Engineering Services 70 SARATOGA AVE. * SUITE 200 SANTA CLARA, CA. 95051-7301 PHONE: (408)261-3500 * FAX (408)261-4176 www.IEEngineering.net	
DESIGNED	TR	CHECKED	LC
DRAWN	HL	CADD FILE NAME	-



APPROVED	
CADD FILE DATE	SCALE
APRIL 15, 2020	NONE
PLOT DATE	BOARD APPROVAL DATE
-	-

CERONE DIVISION BOILER AND PROPANE TANK REPLACEMENT PLUMBING DETAILS			SHEET OF 49 DRAWING NO. <b>P17</b> REVISION 1
SAP NO.	CONTRACT NO. C19123	FILE LOCATION	



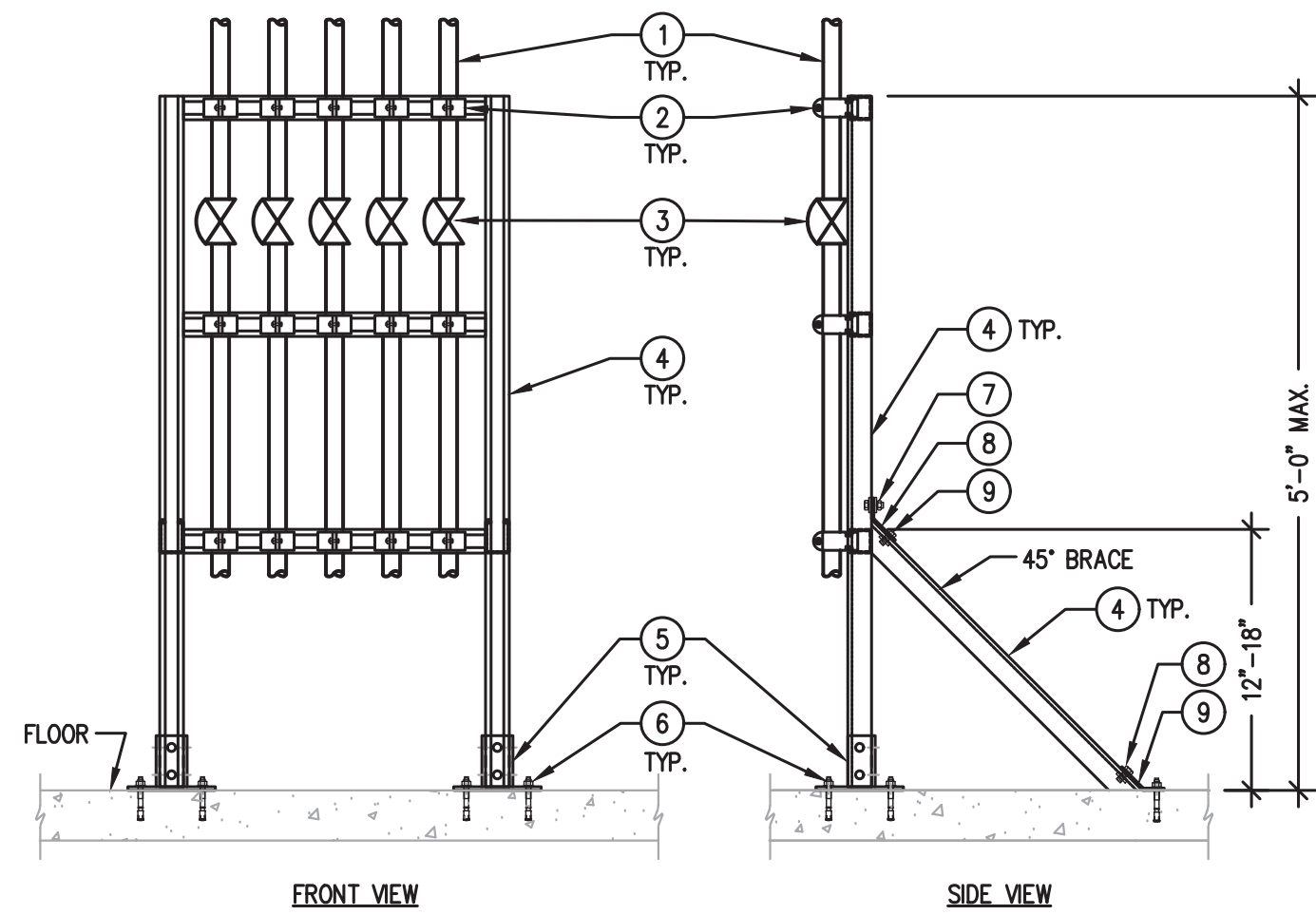

- NOTES:
- PIPE DROP FROM CEILING.
  - PIPE CLAMP WITH 1/8" THICK NEOPRENE SLEEVE.
  - SHUT OFF VALVE AT 5'-0" AFF.
  - 1-5/8"x1-5/8" UNISTRUT P1000 CHANNEL.
  - 1-5/8"x1-5/8" UNISTRUT P1000 BASE PLATE UNISTRUT P2072A SQ.
  - HILTI KWIK BOLT TZ. (TYP.)
  - 1/2"x1-1/4" HEX BOLT, FENDER WASHER AND NUT.
  - L-BRACKET. UNISTRUT P6546.
  - 1/2"x1-1/4" HEX BOLT, FENDER WASHER AND LUG.

5 VERTICAL UNISTRUT PIPE RACK DETAIL  
- NTS

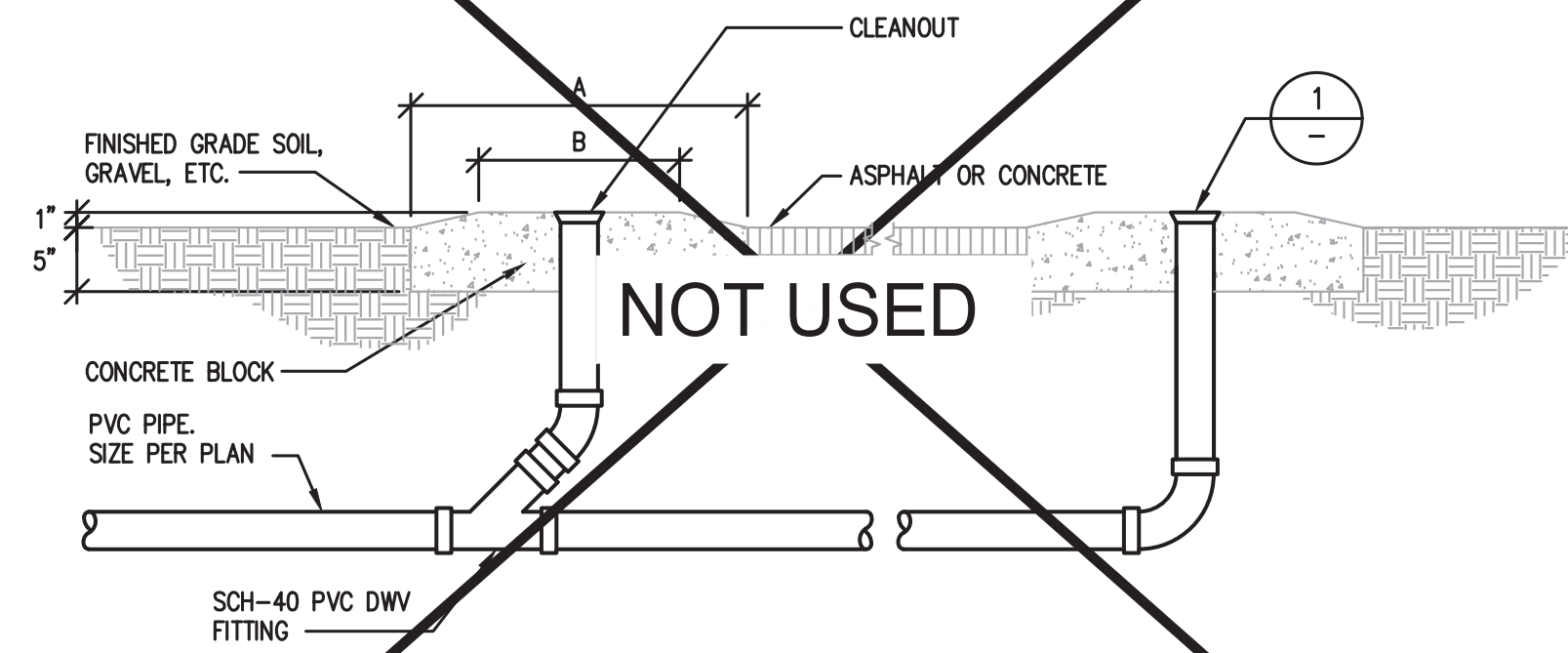

3 CLEANOUT TO GRADE  
- NTS

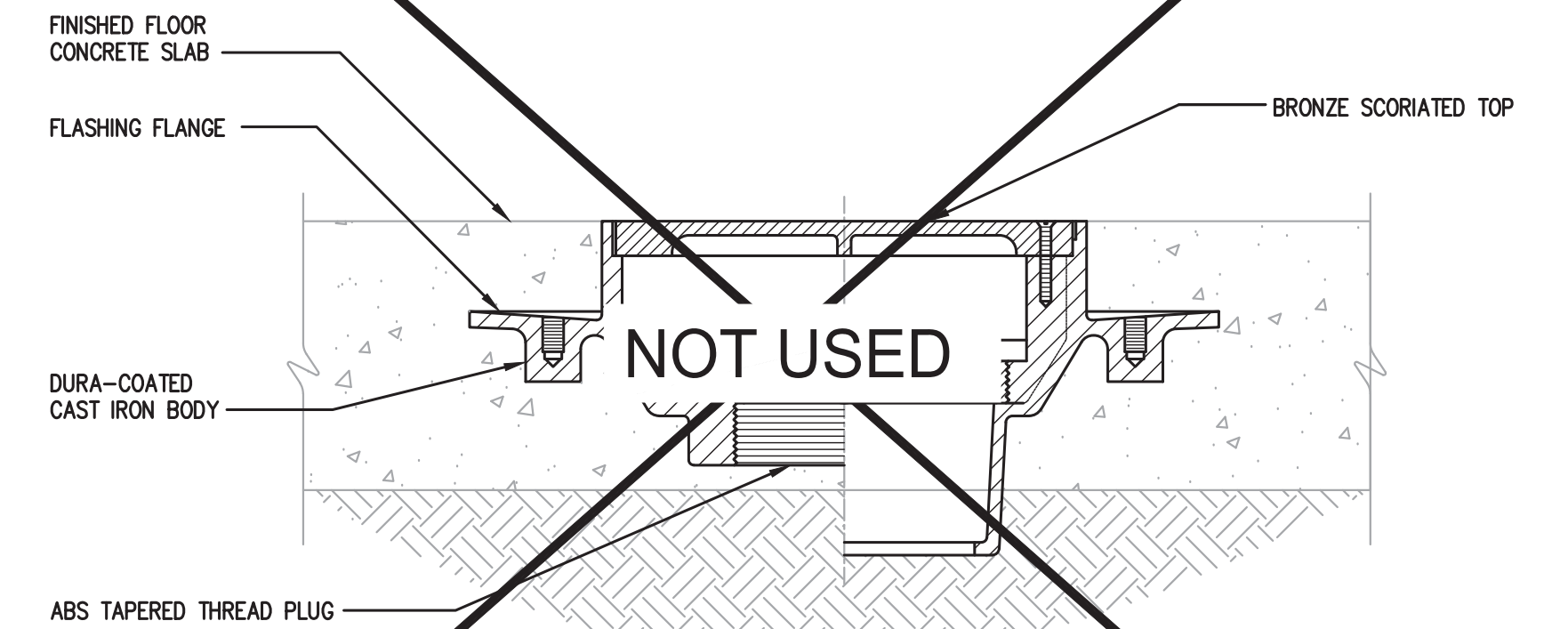

- NOTE:
- FLOOR CLEANOUT, ZURN PART Z1455.

1 FLOOR CLEANOUT DETAIL  
- NTS

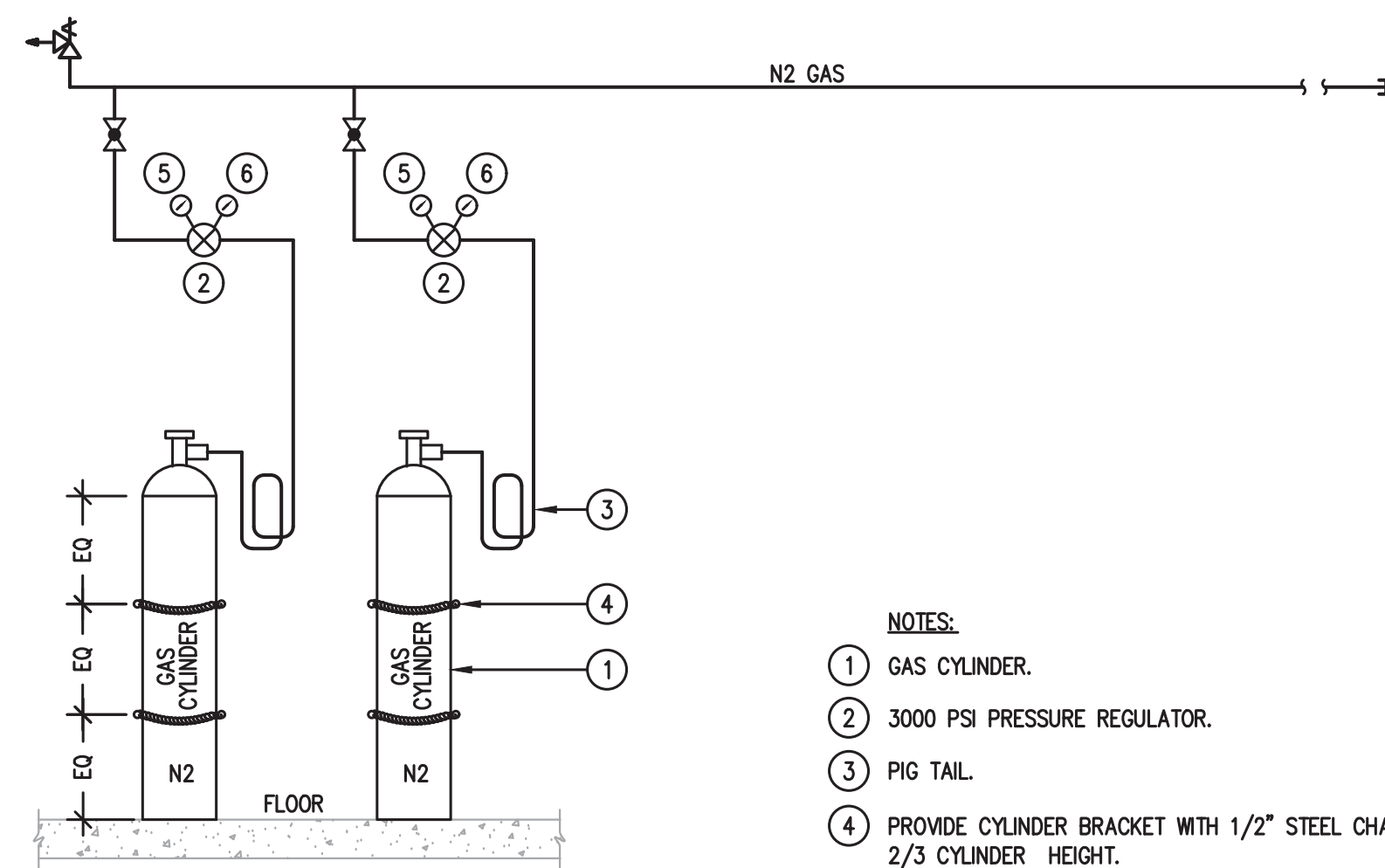

- NOTES:
- GAS CYLINDER.
  - 3000 PSI PRESSURE REGULATOR.
  - PIG TAIL.
  - PROVIDE CYLINDER BRACKET WITH 1/2" STEEL CHAIN AT 1/3 AND 2/3 CYLINDER HEIGHT.
  - 0-100 PSI SS PRESSURE GAUGE.
  - 0-3000 PSI SS PRESSURE GAUGE.

6 DUPLEX INERT GAS CYLINDERS  
MANIFOLD DIAGRAM  
- NTS MANIFOLD

- NOTES:
- INSTALLATION DETAIL APPLIES TO GAS CYLINDERS INSTALLED AGAINST A WALL, OR AGAINST A UNISTRUT CHANNEL RACK.
  - INSTALLATION DETAIL APPLIES TO GAS CYLINDERS SIZES-K, A & AL FOR CYLINDERS 42-1/2" OR SHORTER, USE ONE SEISMIC CHAIN.
  - VERTICAL U-STRUT CHANNEL, 3 EACH FOR 2-CYL./3-CYL. RACK, 2-EA. FOR 1-CYLINDER RACK.
  - CYLINDER SEISMIC RESTRAINT ALUMINUM BRACKET AND CHAIN AT 1/3 & 2/3 CYL. HEIGHT. APPLIES TO FREE STANDING CYL. AND TO CYL. INSTALLED IN GAS CABINETS.

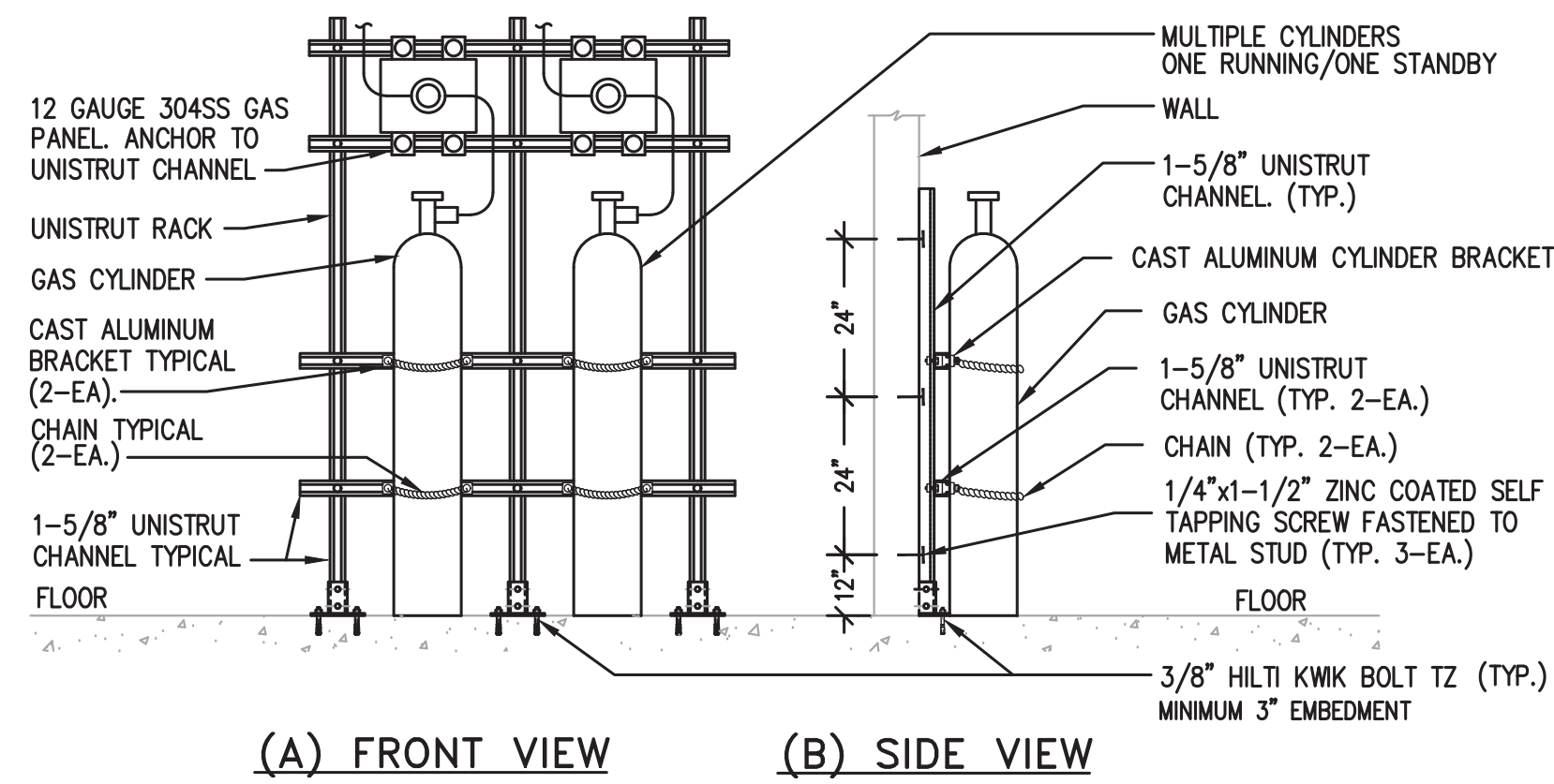

4 FREE STANDING GAS CYLINDER(S)  
SUPPORT DETAIL  
- NTS

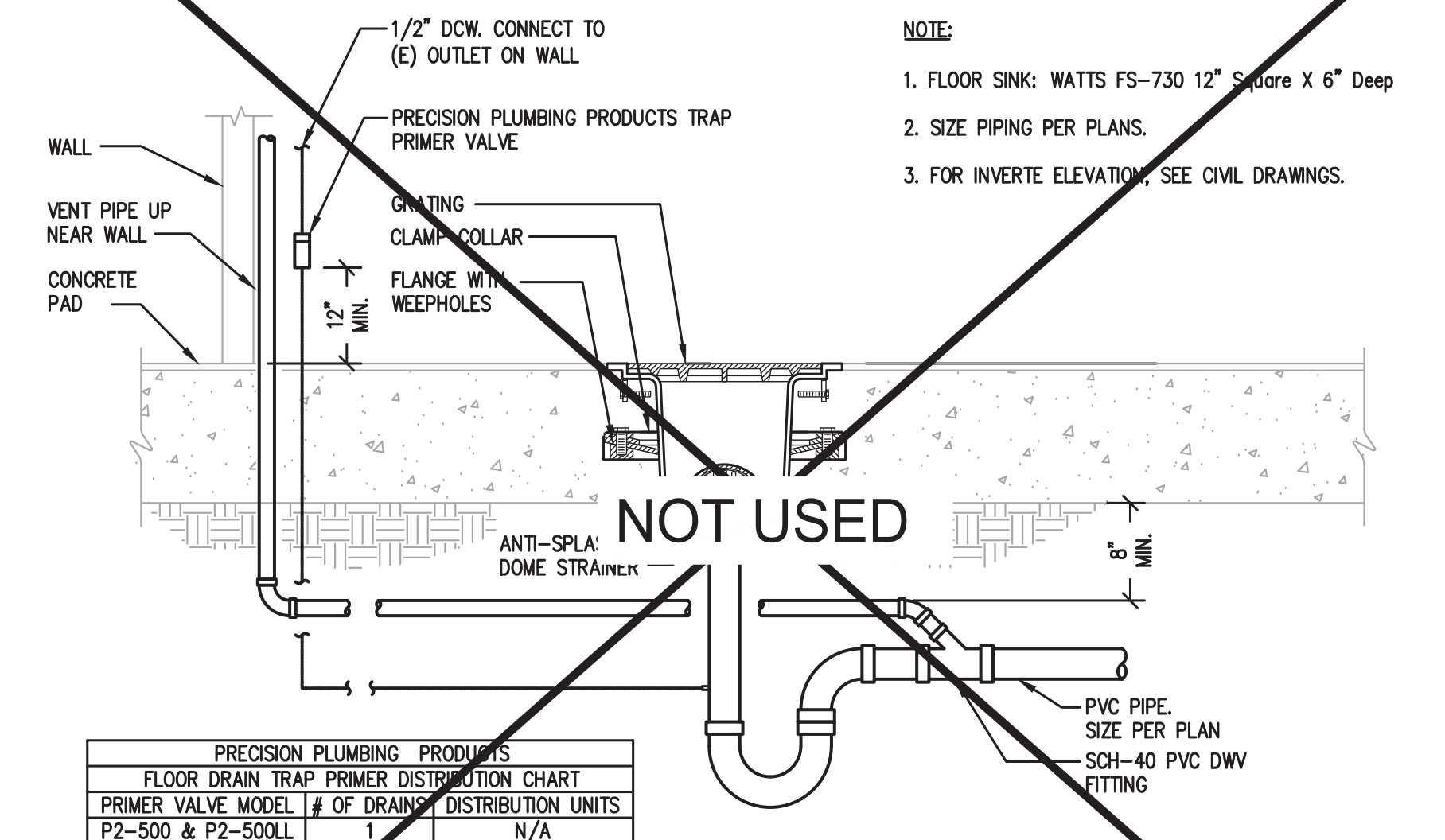

- NOTE:
- FLOOR SINK: WATTS FS-730 12" Square X 6" Deep
  - SIZE PIPING PER PLANS.
  - FOR INVERT ELEVATION, SEE CIVIL DRAWINGS.

2 FLOOR SINK DETAIL  
- NTS

NO.	DATE	REVISIONS
1	06/01/20	ISSUE FOR BID



SUBMITTED		Integrated Engineering Services 70 SARATOGA AVE. * SUITE 200 SANTA CLARA, CA. 95051-7301 PHONE: (408)261-3500 * FAX (408)261-4176 www.IEEngineering.net	
DESIGNED	TR	CHECKED	LC
DRAWN	HL	CADD FILE NAME	-



APPROVED	
CADD FILE DATE	SCALE
APRIL 15, 2020	NONE
PLOT DATE	BOARD APPROVAL DATE
-	-

CERONE DIVISION BOILER AND PROPANE TANK REPLACEMENT			SHEET 30 OF 49
PLUMBING DETAILS			DRAWING NO. P18
SAP NO.			REVISION 1
CONTRACT NO. C19123	FILE LOCATION		



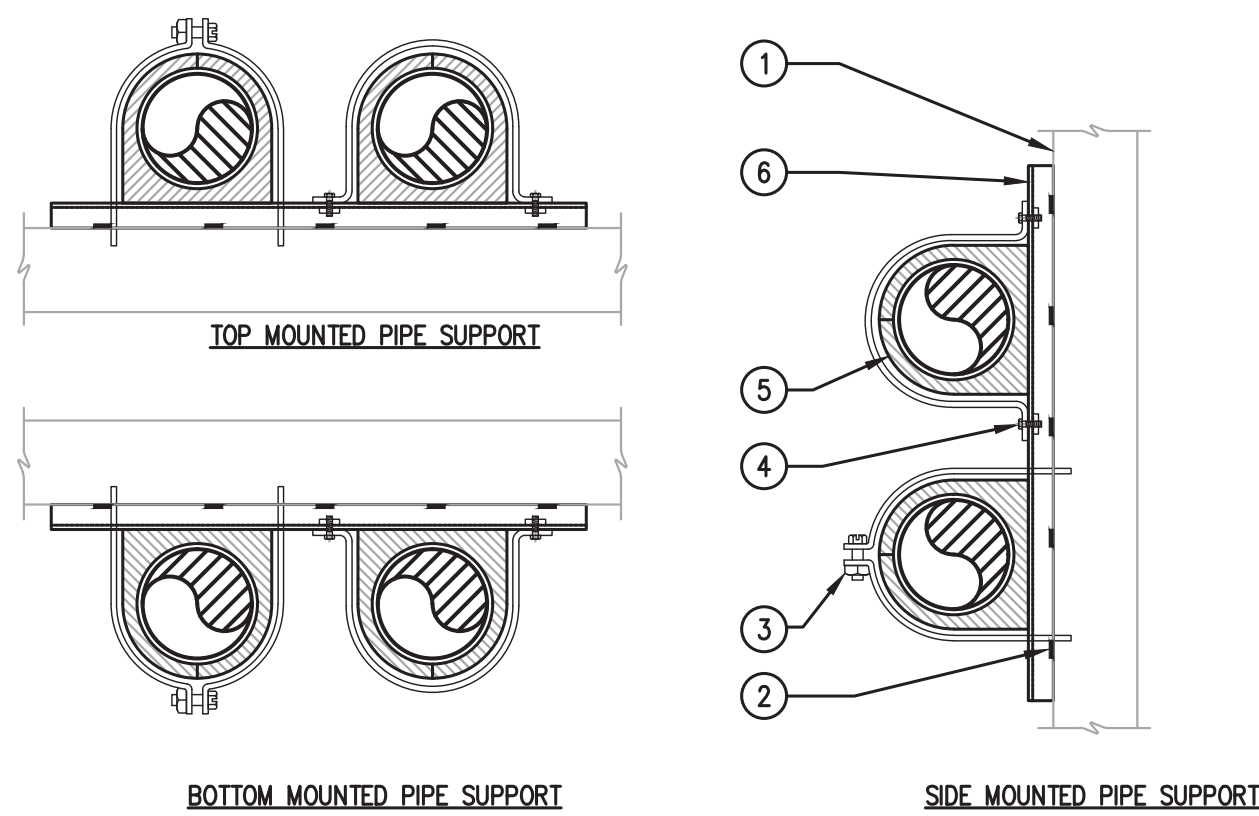

- GENERAL NOTES:**
1. ALLOW SUFFICIENT SPACE BETWEEN PIPE AND PIPE-CLAMP FOR PIPE EXPANSION AND CONTRACTION.
  2. USE NEOPRENE SLEEVE OVER PLASTIC PIPE AT PIPE SUPPORT.
- KEYED NOTES:**
- 1 TUBULAR STEEL COLUMN.
  - 2 1/4"x2" LONG WELD, 6" O.C. BOTH SIDES.
  - 3 2 PIECE PIPE CLAMP WITH HEX BOLT AND NUT.
  - 4 HEX BOLT, WASHER AND LUG.
  - 5 USE "THERMAL HANGER SHIELD" OR "SADDLE" AT PIPE SUPPORT.
  - 6 1-5/8"x 1-5/8", UNISTRUT P1000 CHANNEL.

5 PIPE SUPPORT ON STEEL FRAMING  
- NTS

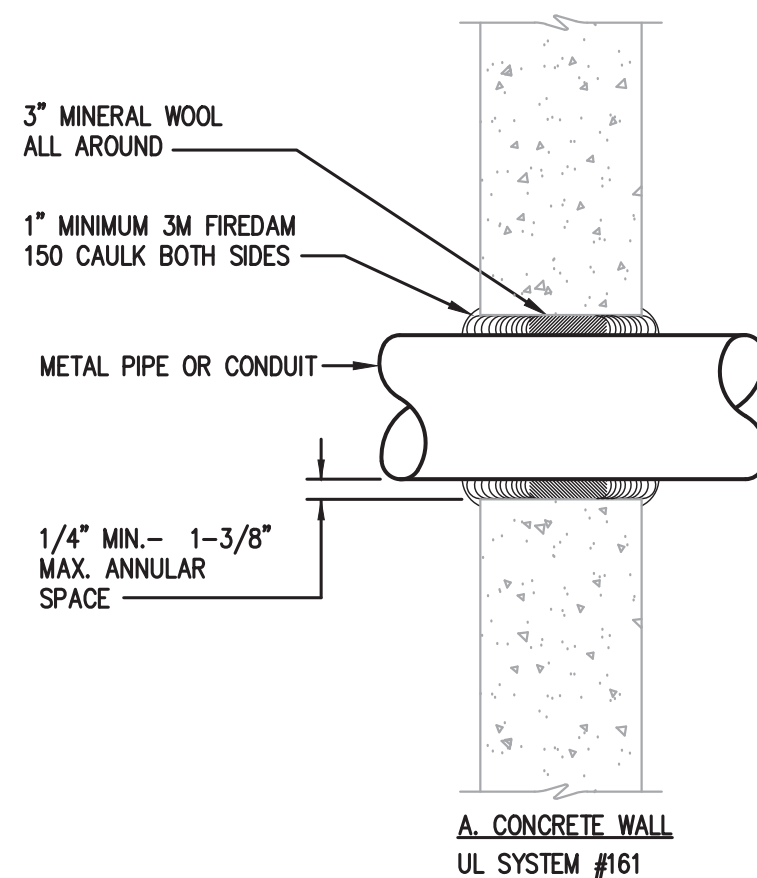

- NOTES:**
1. APPLIES TO 6" MAX. DIA METAL PIPE, FIRE RATED AND NONE RATED WALL.
  2. APPLIES TO 1-HR AND 2-HR FIRE RATED WALL.

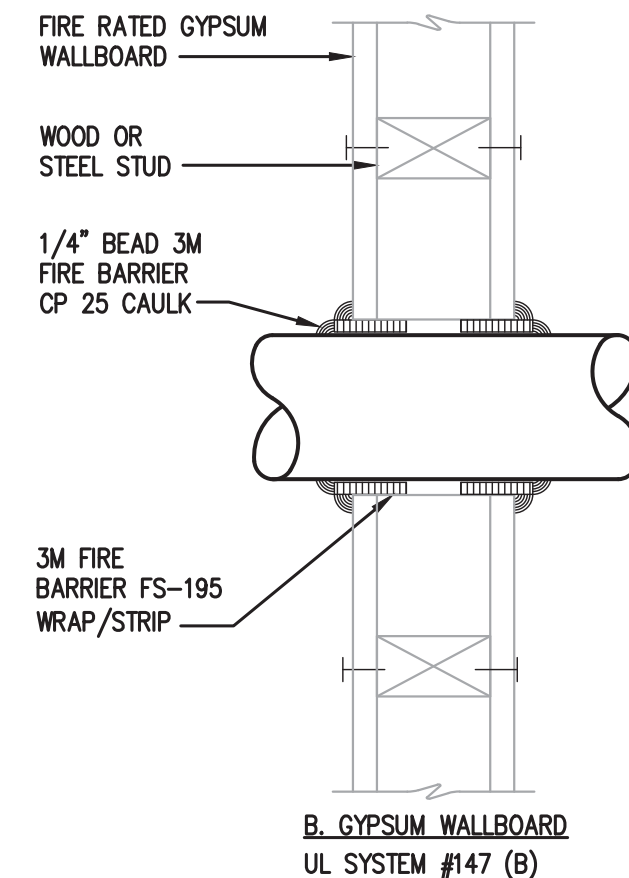

3 METAL PIPE PENETRATION THROUGH WALL DETAIL  
- NTS

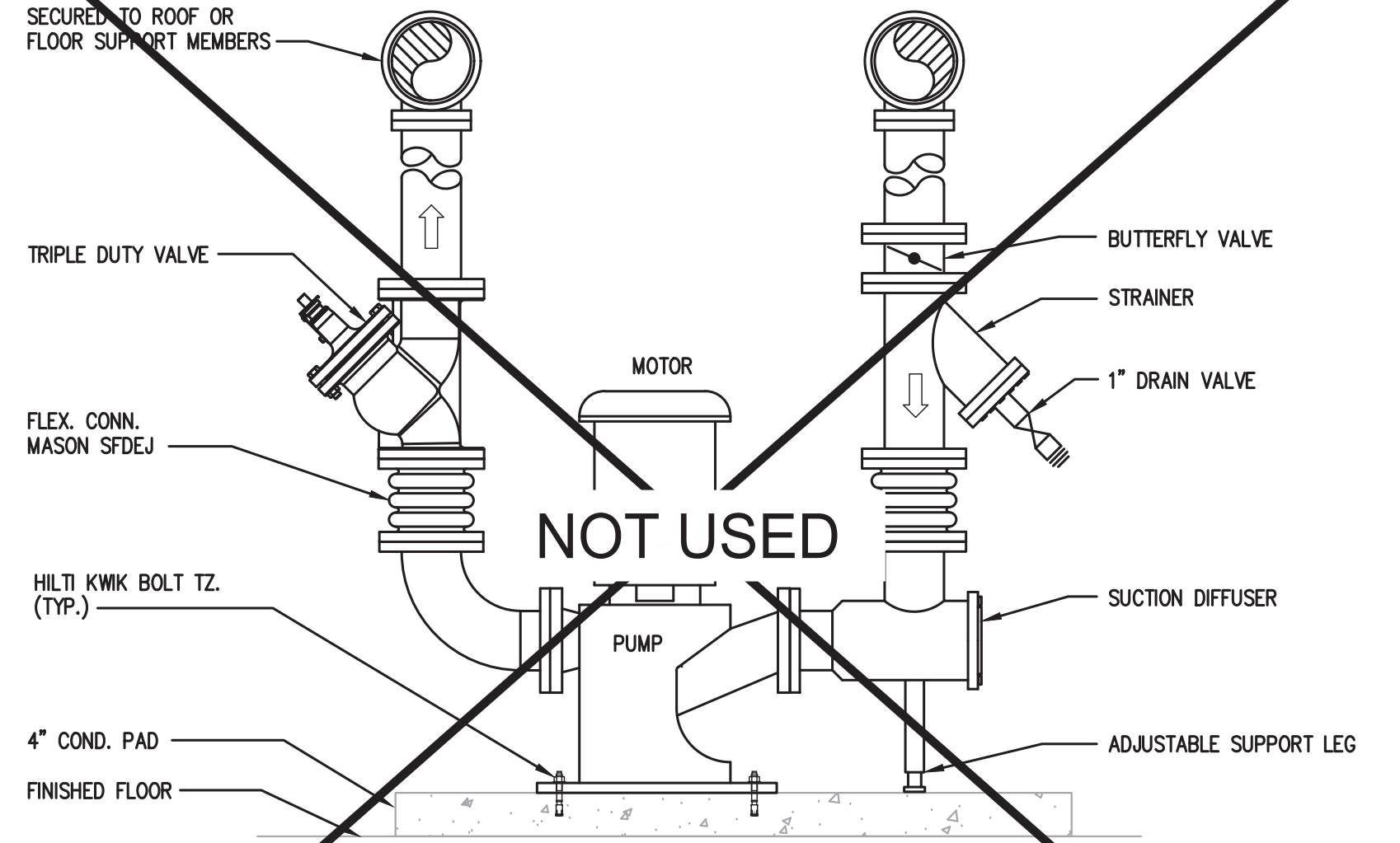

1 VERTICAL CENTRIFUGAL PUMP INSTALLATION DETAIL  
- NTS

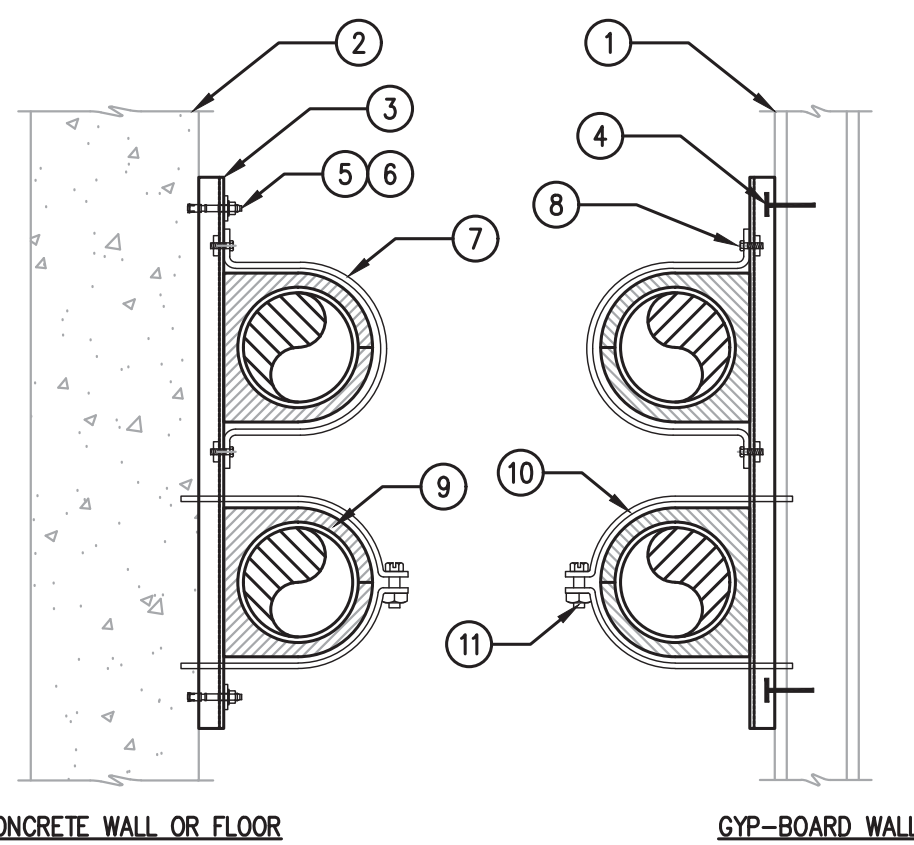

- GENERAL NOTES:**
1. ALLOW SUFFICIENT SPACE BETWEEN PIPE AND PIPE-CLAMP FOR PIPE EXPANSION AND CONTRACTION.
  2. USE NEOPRENE SLEEVE OVER PLASTIC PIPE AT PIPE SUPPORT.
  3. PROVIDE PIPE SUPPORT AT 4'-0" ON CENTER.
- KEYED NOTES:**
- 1 GYP-BOARD WALL.
  - 2 CONCRETE WALL/FLOOR SLAB.
  - 3 UNISTRUT CHANNEL P1000.
  - 4 1/4" x 1-1/2" ZINC COATED SELF-TAPPING SCREW FASTENED TO METAL STUD.
  - 5 FOR 1-1/2" PIPE OR LESS USE 3/8" HILTI KWIK BOLT TZ WITH 2" MINIMUM EMBEDMENT.
  - 6 FOR 2" PIPE AND LARGER USE 1/2" HILTI KWIK BOLT TZ WITH 3" MINIMUM EMBEDMENT.
  - 7 U-CLAMP.
  - 8 HEX BOLT WITH FENDER WASHER AND SPRING LOADED CHANNEL NUT.
  - 9 USE "THERMAL HANGER SHIELD" OR "SADDLE" AT PIPE SUPPORT.
  - 10 Z-PIECE CLAMP.
  - 11 HEX BOLT AND NUT.
- ALLOW SUFFICIENT SPACE BETWEEN PIPE AND PIPE-CLAMP FOR PIPE EXPANSION AND CONTRACTION.
- USE NEOPRENE SLEEVE OVER PLASTIC PIPE AT PIPE SUPPORT.
- PROVIDE PIPE SUPPORT AT 4'-0" ON CENTER.

6 TYPICAL WALL OR FLOOR MOUNTED PIPE RACK  
- NTS

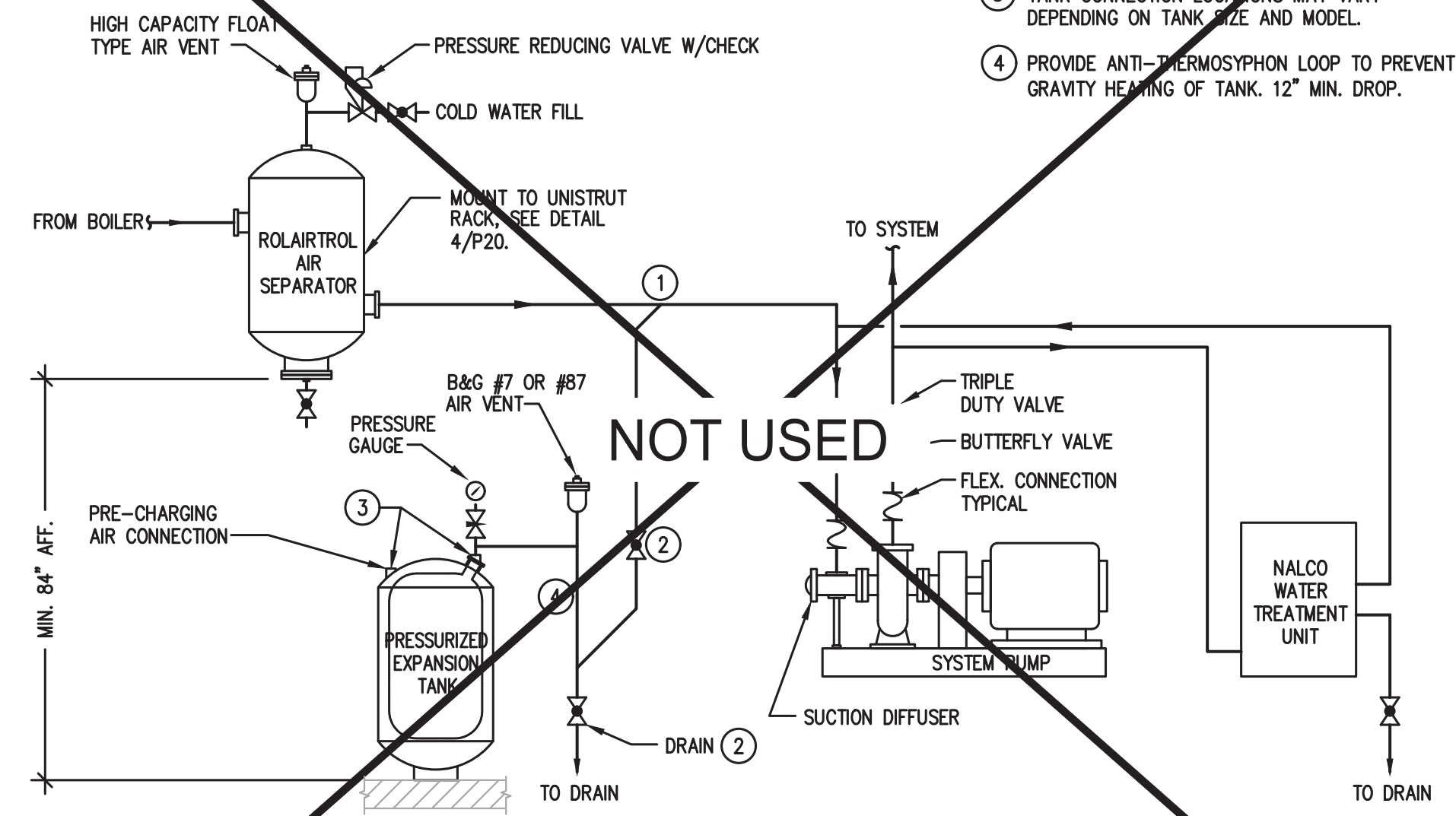

- NOTES:**
- 1 CONNECT TO SIDE OF HORIZONTAL HWS. AVOID TOP OR BOTTOM CONNECTION TO PREVENT AIR OR DEBRIS FROM ENTERING PIPE TO TANK.
  - 2 SHUT-OFF VALVE, DRAIN VALVE ALSO REQUIRED TO PRECHARGE TANK.
  - 3 TANK CONNECTION LOCATIONS MAY VARY DEPENDING ON TANK SIZE AND MODEL.
  - 4 PROVIDE ANTI-THERMOSYPHON LOOP TO PREVENT GRAVITY HEATING OF TANK. 12" MIN. DROP.

2 VERTICAL EXPANSION TANK AND ROLAIRTROL  
- NTS

NO.	DATE	REVISIONS
1	06/01/20	ISSUE FOR BID



SUBMITTED		Integrated Engineering Services 70 SARATOGA AVE. * SUITE 200 SANTA CLARA, CA. 95051-7301 PHONE: (408)261-3500 * FAX (408)261-4176 www.IESengineering.net	
DESIGNED	TR	CHECKED	LC
DRAWN	HL	CADD FILE NAME	-



APPROVED	
CADD FILE DATE	SCALE
APRIL 15, 2020	NONE
PLOT DATE	BOARD APPROVAL DATE
-	-

CERONE DIVISION BOILER AND PROPANE TANK REPLACEMENT			SHEET 31
PLUMBING DETAILS			OF 49 DRAWING NO. P19
SAP NO.	CONTRACT NO. C19123	FILE LOCATION	REVISION 1



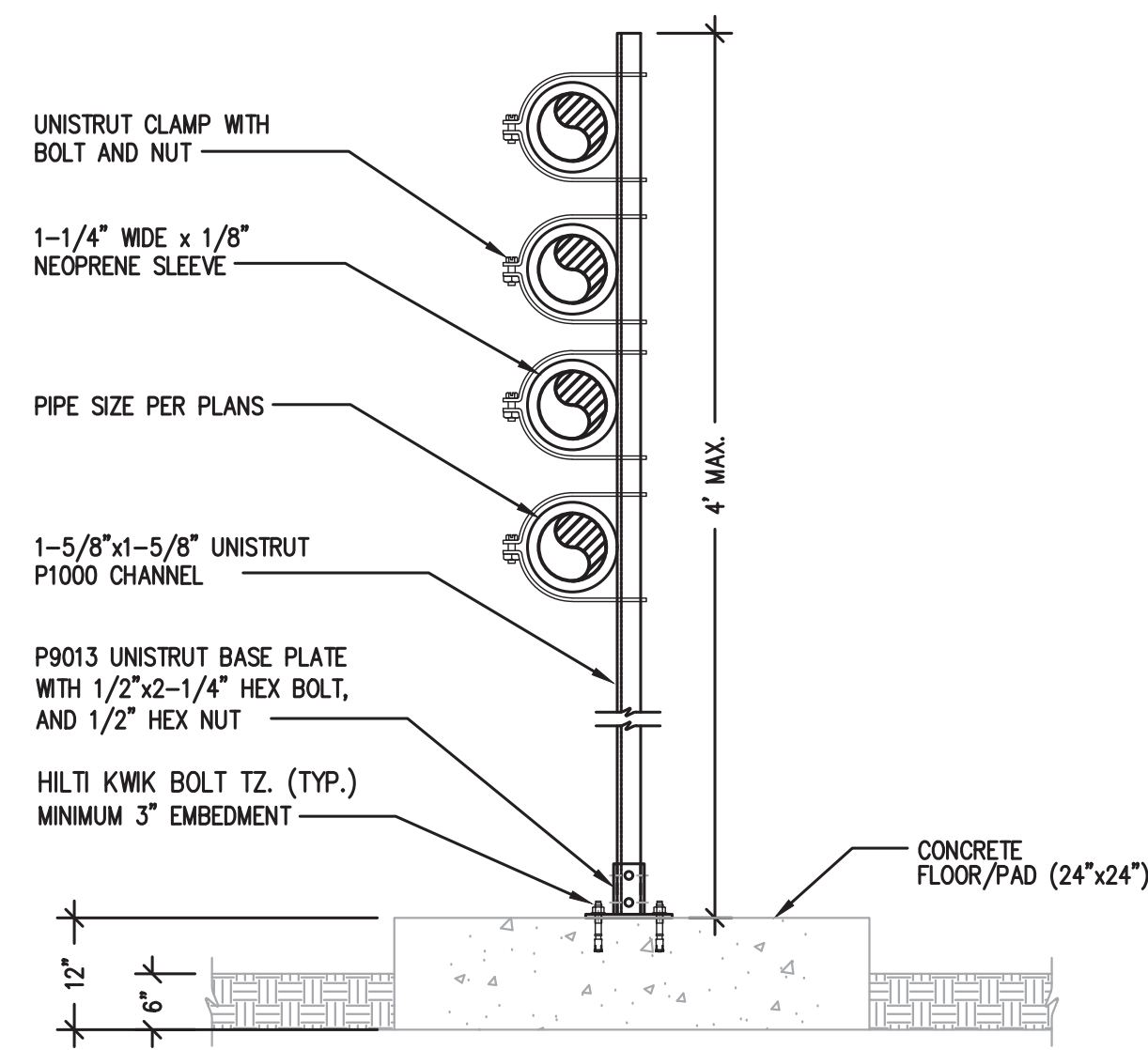

**5 VERTICAL FLOOR MOUNTED PIPE RACK DETAIL**  
- NTS

- NOTES:
- ① 3"x3"x1/4" ANGLE WELDED TO PIPE ANCHOR PLATE & STRUCTURAL STEEL.
  - ② 1/2" STEEL ANCHOR PLATE.
  - ③ PIPE ANCHOR CLAMP.
  - ④ INSULATED PIPE—STOP INSULATION AT PIPE CLAMP.
  - ⑤ 1/2" CLAMP BOLTS.
  - ⑥ 1/2" NEOPRENE FULL LENGTH OF CLAMP.

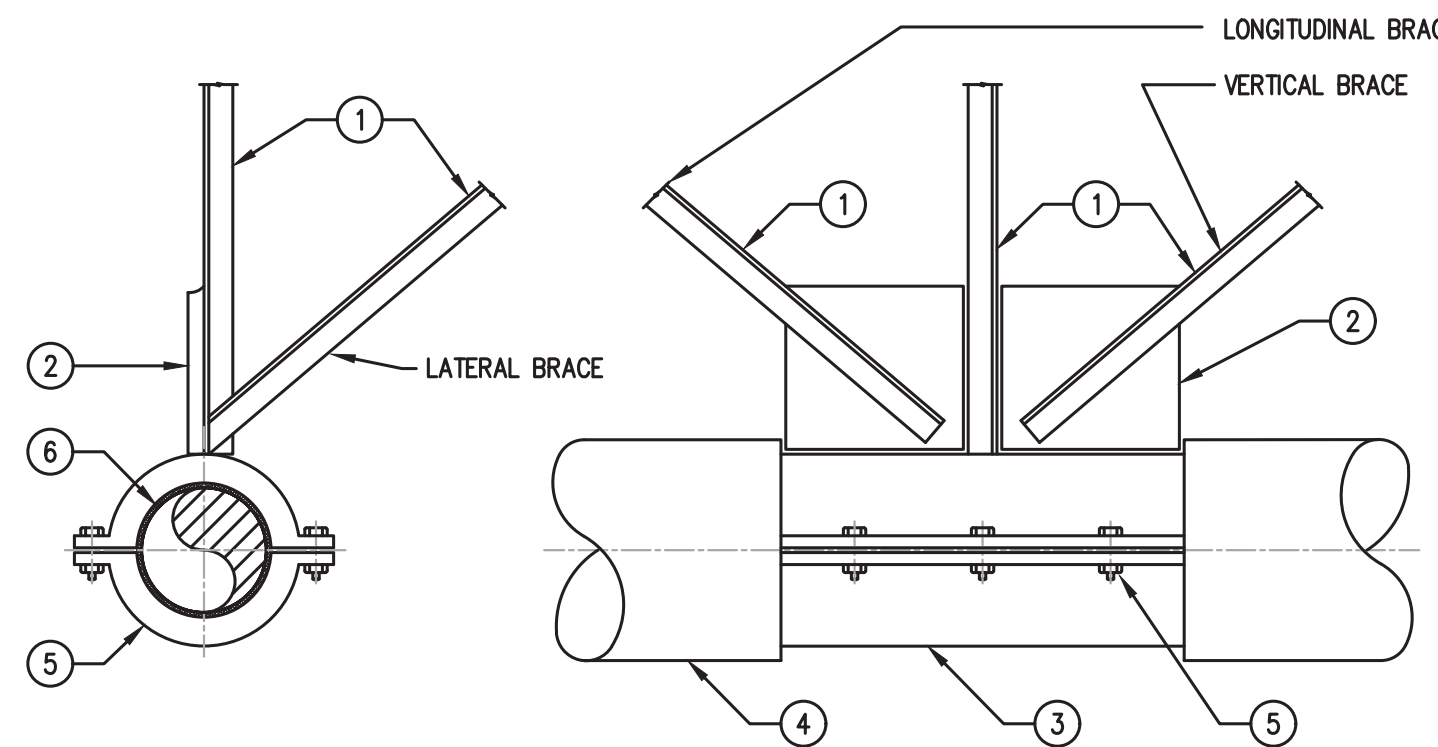

**3 PIPE ANCHOR DETAIL**  
- NTS

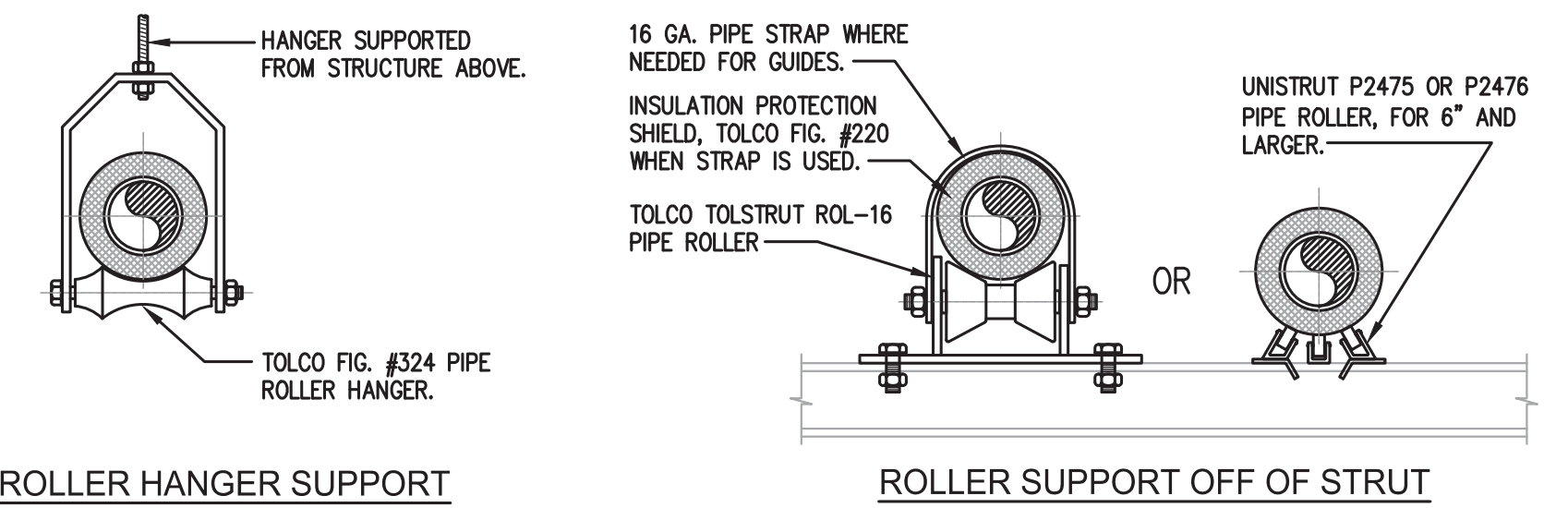

**ROLLER HANGER SUPPORT**

**ROLLER SUPPORT OFF OF STRUT**

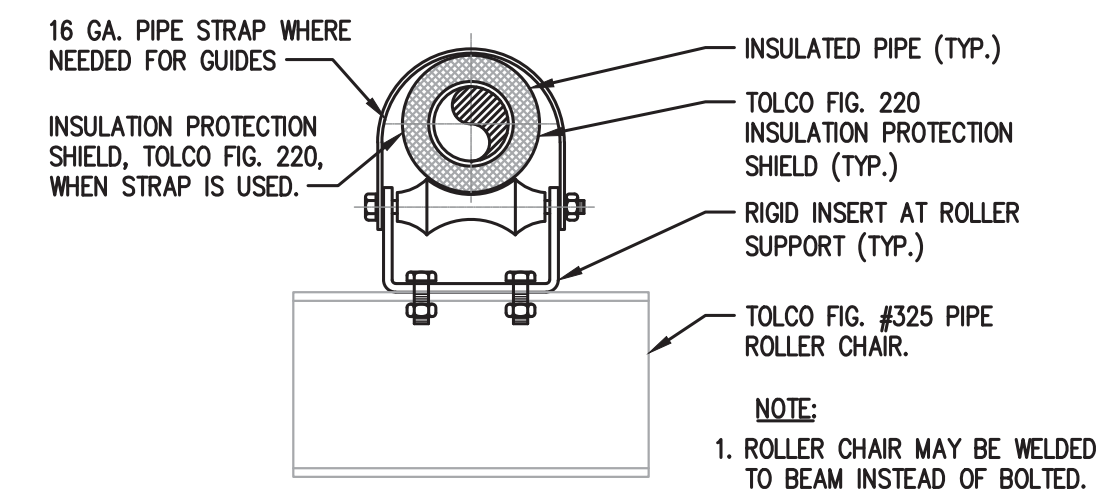

**SUPPORT OFF A RACK OR STEEL BEAM**

**1 PIPING SUPPORT FOR HHWS/R 4" AND SMALLER**  
- NTS

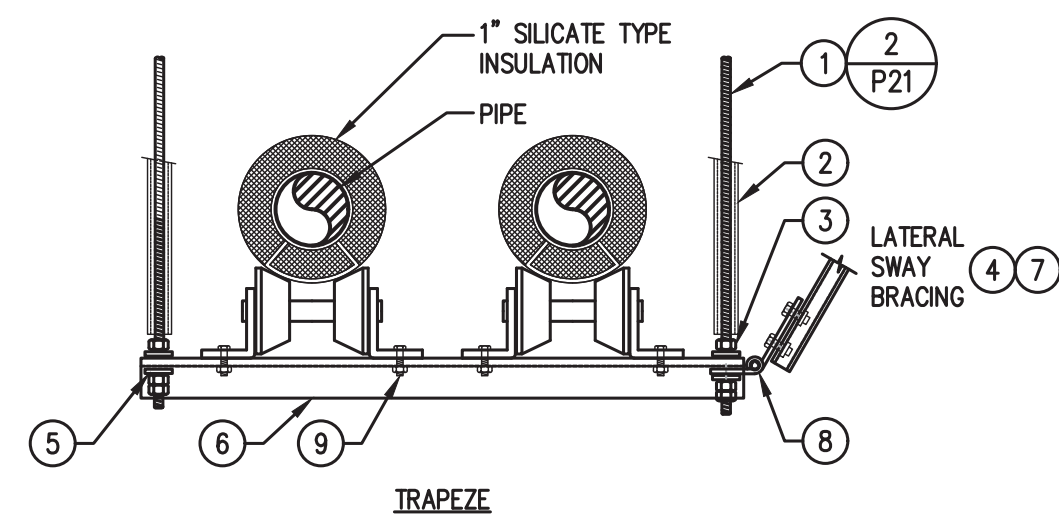

**GENERAL NOTES:**

- 1. PROVIDE PIPE INSULATION SHIELD FOR ALL INSULATED PIPE AT HANGERS.
- 2. INSTALL TRAPEZE PIPE RACK AT INTERVALS PER SMACNA GUIDELINES.
- 3. CONTRACTOR TO PROVIDE STRUCTURAL CALCULATIONS FOR PIPE RACK SUPPORT AND SEISMIC BRACING DESIGN FOR APPROVAL.

**KEYED NOTES:**

- ① 3/8", OR 1/2", OR 3/4" ALL THREAD ROD AS APPLICABLE. REFER TO SMACNA SEISMIC GUIDELINES TABLES 5-7 & 5-8.
- ② VERTICAL STIFFENERS FOR 18" OR LONGER HANGER RODS PER SMACNA STANDARDS. REFER TO SMACNA SEISMIC GUIDELINES FIGURE 9-11. (TYP.)
- ③ FENDER WASHER AND NUT. (TYP.)
- ④ PROVIDE LATERAL AND LONGITUDINAL SEISMIC BRACING AT 20'-0" O.C. AND AT EVERY TURN IN DIRECTION PER SMACNA SEISMIC GUIDELINES. (REFER TO SMACNA FIGURES 4-15, 4-20, 4-21).
- ⑤ FENDER WASHER, NUT AND LOCKNUT. (TYP.)
- ⑥ 3"x3"x3/8" IRON ANGLE. UNISTRUT CHANNEL SIZE AS REQUIRED PER SMACNA HVAC DUCT CONSTRUCTION STANDARDS TABLES 5-3.
- ⑦ UNISTRUT P1000 CHANNEL.
- ⑧ 1-5/8" ADJUSTABLE HINGE ANCHOR FITTING. UNISTRUT #P1354A.
- ⑨ BOLT AND NUT. (TYP.)

**HOT WATER PIPING TRAPEZE PIPE RACK WITH BRACING**  
- NTS

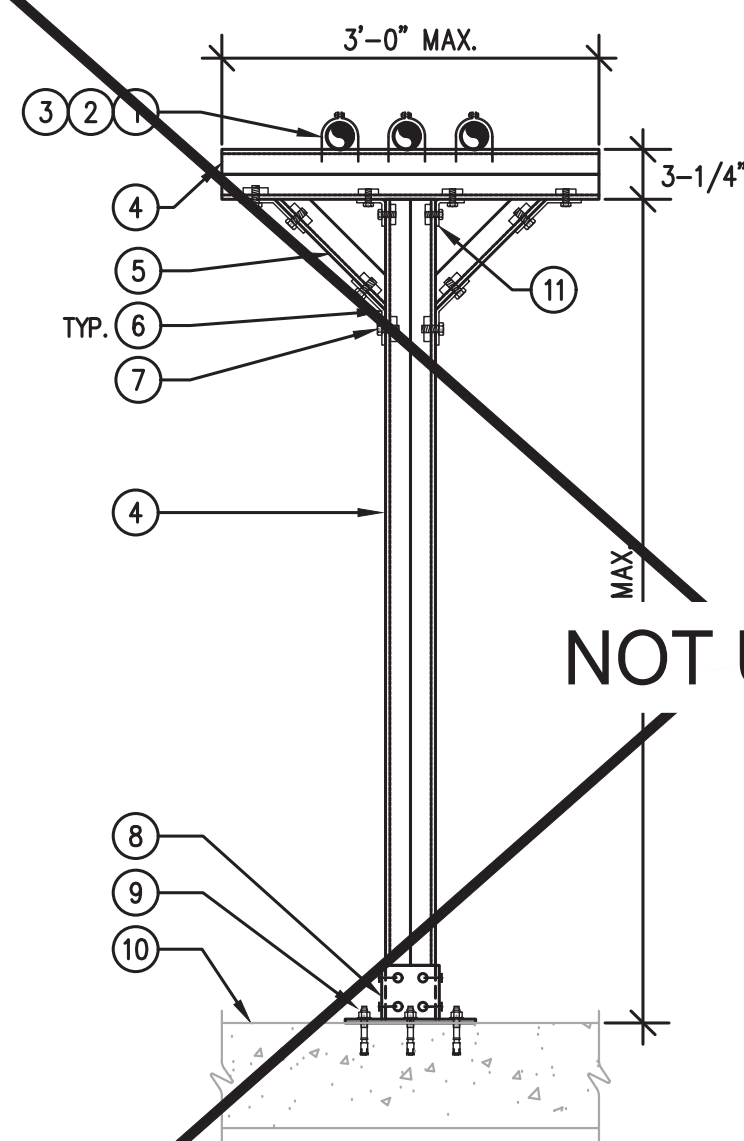

**NOT USED**

**NOTES:**

- ① UNISTRUT CLAMP WITH BOLT AND NUT. SIZE PER PLANS.
- ② PROVIDE NEOPRENE SLEEVES FOR ALL COPPER AND PLASTIC PIPE AT SUPPORTS.
- ③ PROVIDE PIPE INSULATION SHIELD FOR ALL INSULATED PIPE AT SUPPORTS.
- ④ 1-5/8"x3-1/4" UNISTRUT P1001 CHANNEL.
- ⑤ 1-5/8"x1-5/8" UNISTRUT P1000 CHANNEL.
- ⑥ 1-5/8"x1-5/8" x 1/4" 45° BRACKET.
- ⑦ 1/2"x1-1/4" HEX BOLT, WASHER AND LUG. (TYP.)
- ⑧ #2073A) UNISTRUT BASE PLATE WITH HEX BOLTS AND LUGS.
- ⑨ 1/2"x6" HILTI KWIK BOLT TZ, MINIMUM 3-1/2" EMBEDMENT. (TYP. 4 EA.)
- ⑩ CONCRETE PAD.
- ⑪ P1026 UNISTRUT L-BRACKET.

**4 OVERHEAD PIPE RACK SUPPORT DETAIL**  
- NTS

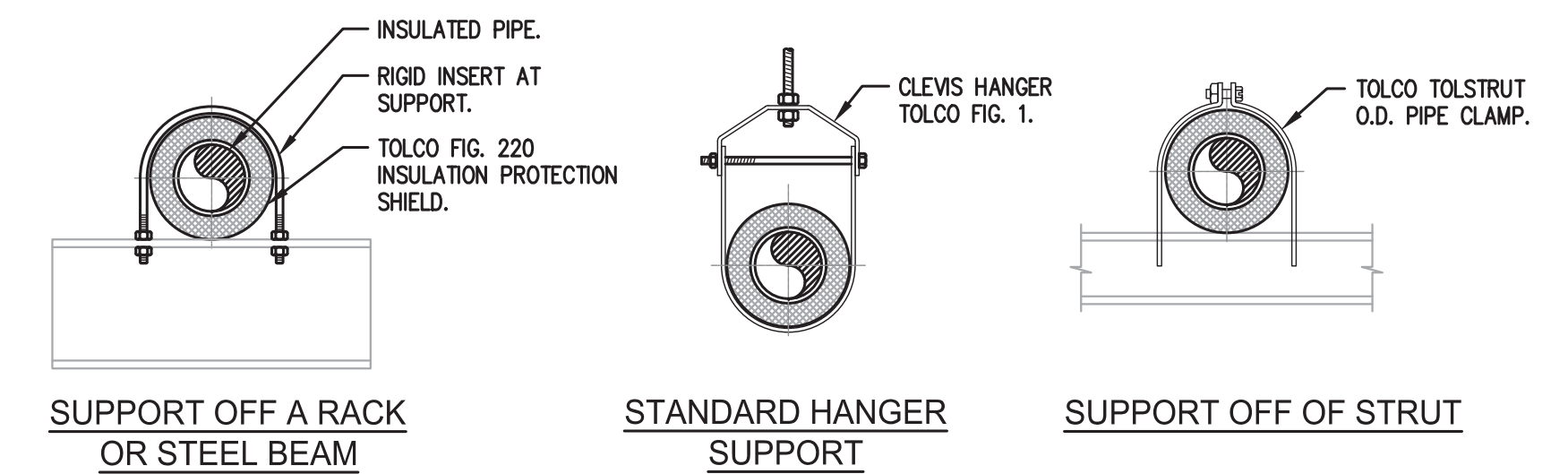

**SUPPORT OFF A RACK OR STEEL BEAM**

**STANDARD HANGER SUPPORT**

**SUPPORT OFF OF STRUT**

**2 PIPING SUPPORT FOR HHWS/R 3" AND SMALLER**  
- NTS

NO.	DATE	REVISIONS
1	06/01/20	ISSUE FOR BID



SUBMITTED		Integrated Engineering Services 70 SARATOGA AVE. * SUITE 200 SANTA CLARA, CA. 95051-7301 PHONE: (408)261-3500 * FAX (408)261-4176 www.IESengineering.net	
DESIGNED	TR	CHECKED	LC
DRAWN	HL	CADD FILE NAME	-



APPROVED	
CADD FILE DATE	SCALE
APRIL 15, 2020	NONE
PLOT DATE	BOARD APPROVAL DATE
-	-

CERONE DIVISION BOILER AND PROPANE TANK REPLACEMENT			SHEET 32
PLUMBING DETAILS			OF 49 DRAWING NO. P20
SAP NO.	CONTRACT NO. C19123	FILE LOCATION	REVISION 1



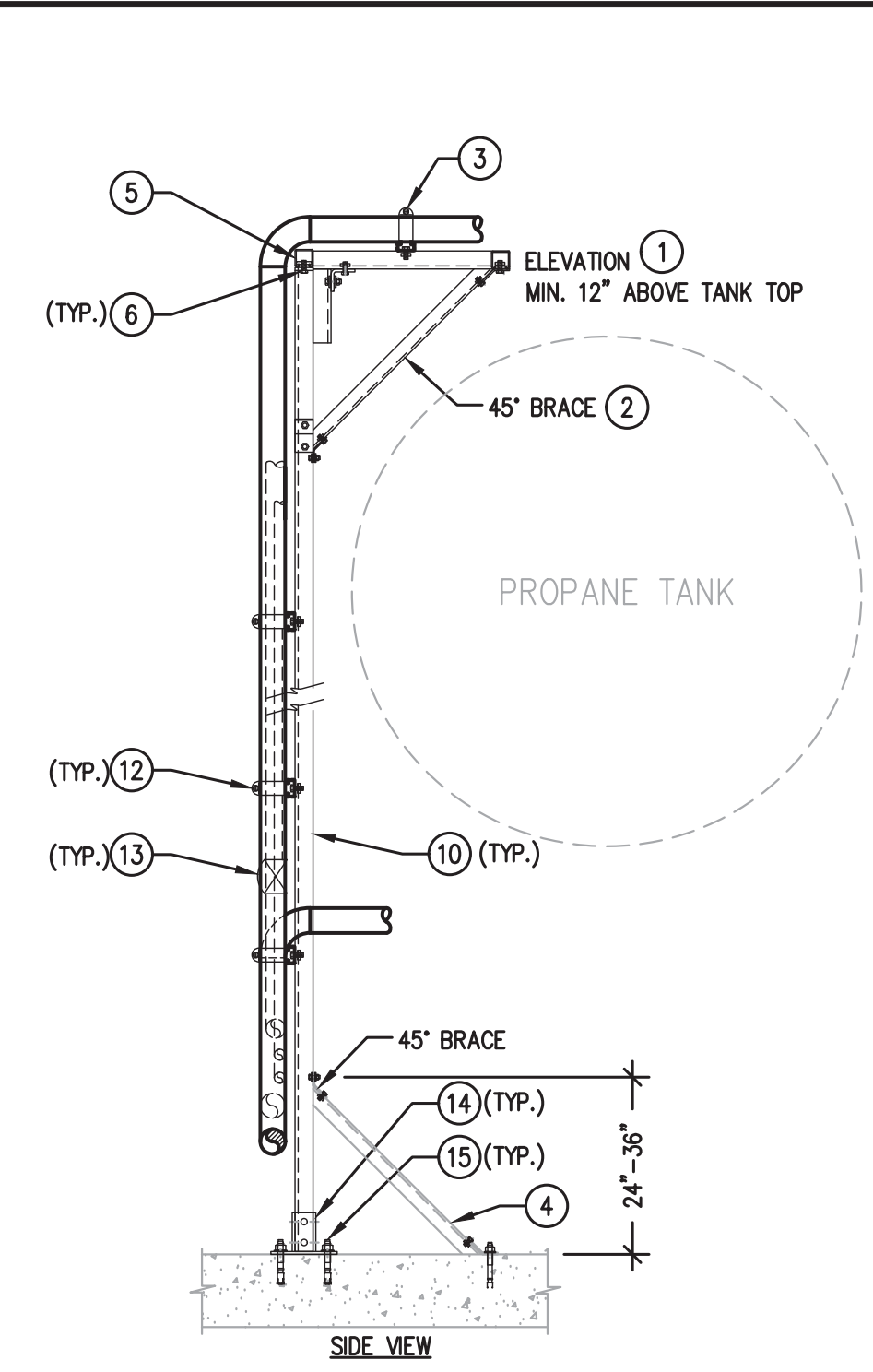
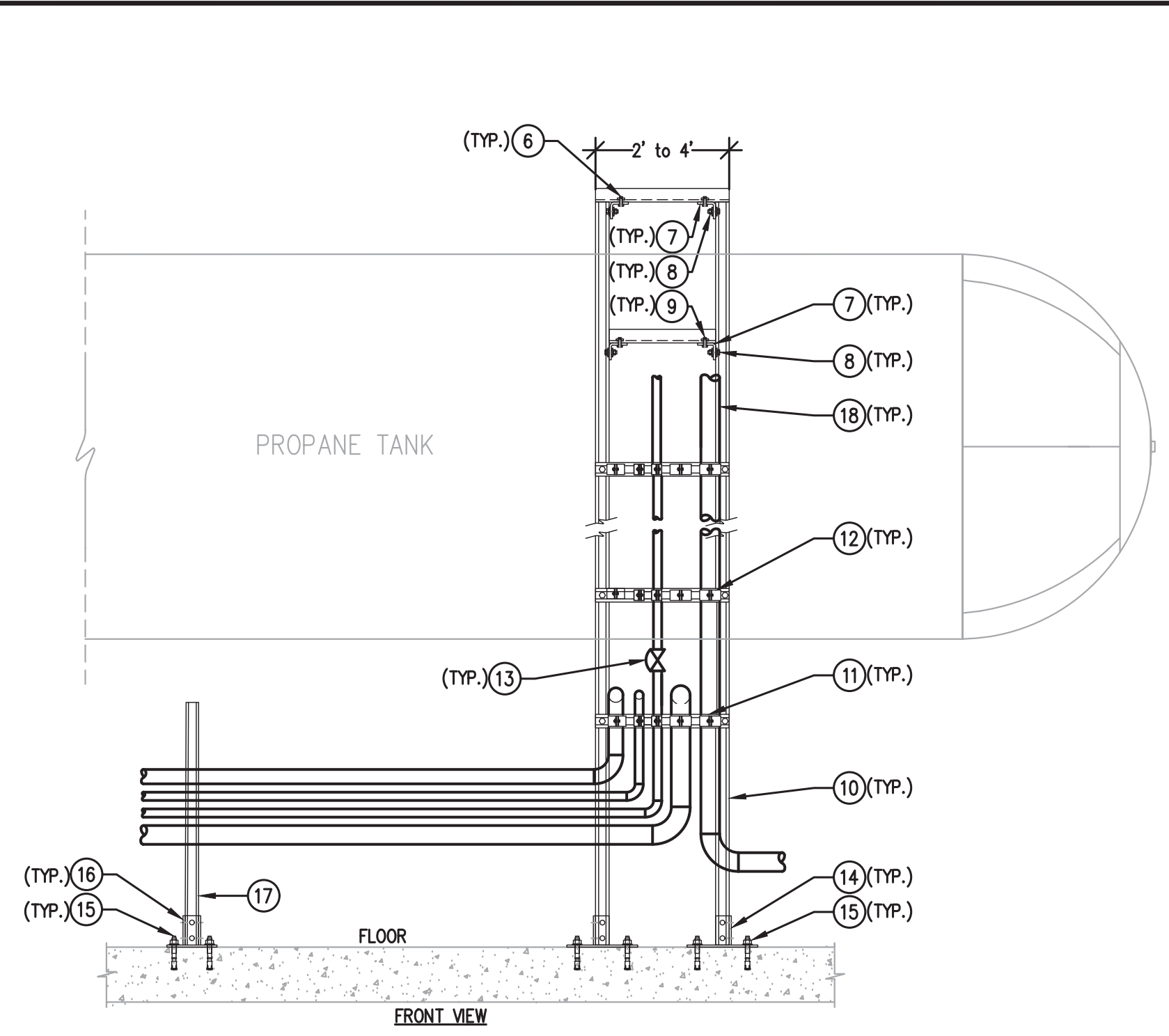

- NOTES:
- 1 HORIZONTAL PIPE RACK UNISTRUT P6026 ABOVE TOP OF TANK. EXTEND CHANNEL TOWARDS CENTER OF TANK W/O INTERFERING WITH TANK AND COMPONENTS.
  - 2 45 DEG ANGLE BRACE LENGTH TO BE FIELD VERIFIED.
  - 3 CROSS CHANNELS (NOT SHOWN) WITH PIPE CLAMPS MATCHING PIPE SIZE
  - 4 45 DEG ANGLE BRACE AT BOTTOM OF PIPE RACK LENGTH TO BE FIELD VERIFIED.
  - 5 UNISTRUT CHANNEL P1000. SIZE AS REQUIRED BY SMACNA STANDARDS LENGTH TO BE FIELD VERIFIED.
  - 6 1/2"x 1-1/4" HEX BOLT, FENDER WASHER AND LUG
  - 7 L-BRACKET. UNISTRUT P6026.
  - 8 1/2"x1-1/4" HEX BOLT, FENDER WASHER AND NUT.
  - 9 1/2"x1-1/4" HEX BOLT, FENDER WASHER AND LUG.
  - 10 UNISTRUT CHANNEL P1000.
  - 11 13/16"x1-5/8" UNISTRUT P4000 SS304 CHANNEL.
  - 12 PIPE CLAMP WITH 1/8" THICK NEOPRENE SLEEVE.
  - 13 SHUT OFF VALVE AT 5'-0" AFF. IF NEEDED.
  - 14 UNISTRUT P1001 BASE PLATE UNISTRUT P2072A.
  - 15 HILTI KWIK BOLT TZ. MINIMUM 3" EMBEDMENT. 4-EACH PER LEG.
  - 16 P9013 UNISTRUT BASE PLATE WITH 1/2"x2-1/4" HEX BOLT, AND 1/2" HEX NUT.
  - 17 1-5/8"x1-5/8" UNISTRUT P1000 CHANNEL.
  - 18 PIPING SIZES AND SEQUENCE PER PIPING FLOOR PLANS

1 VERTICAL PIPE RACK DETAIL AT LPG TANK  
- NTS

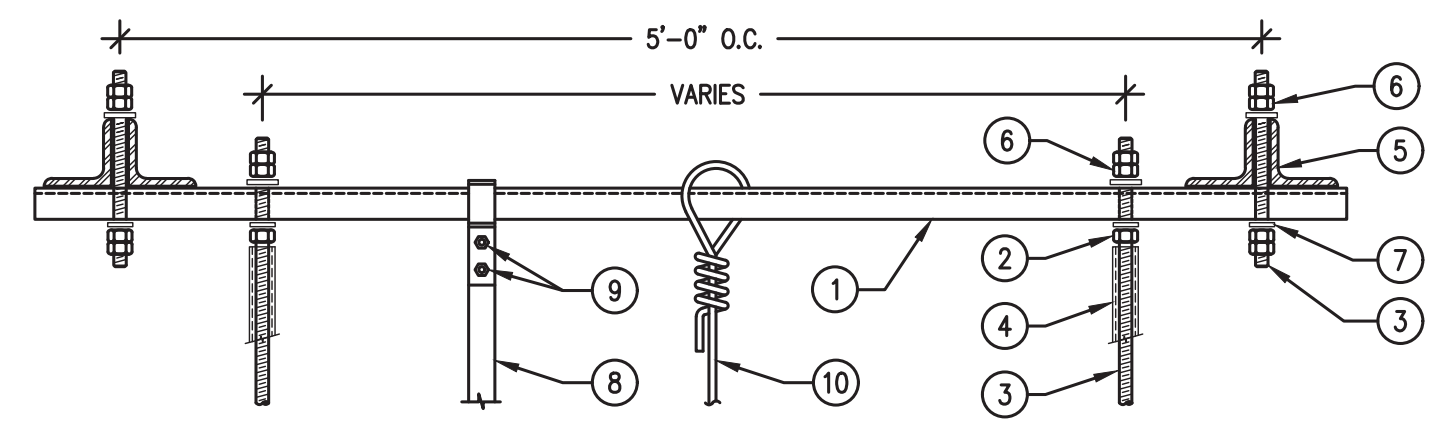
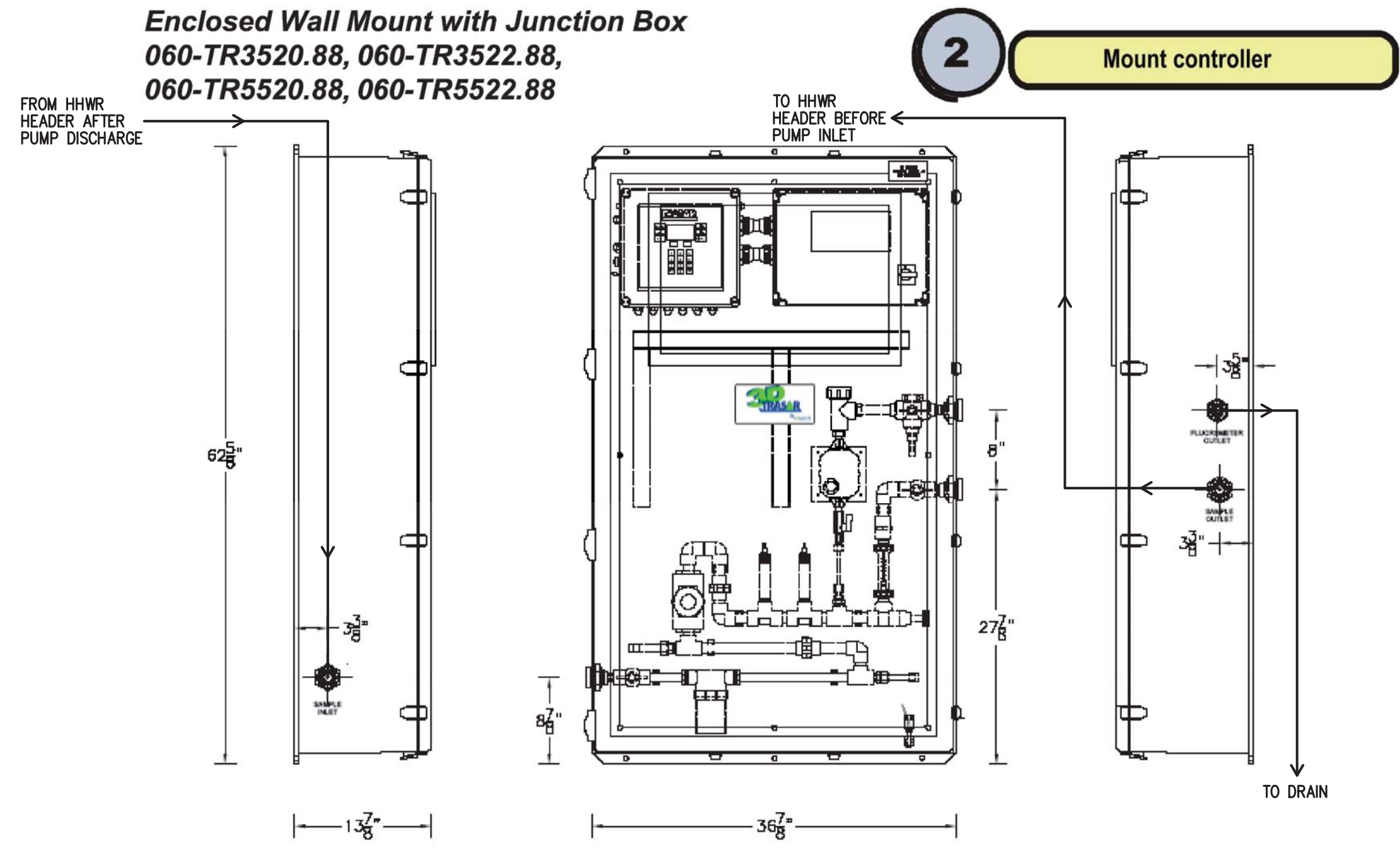

- NOTES:
- 1 UNISTRUT CHANNEL P1000. SIZE AS REQUIRED PER SMACNA HVAC DUCT CONSTRUCTION STANDARDS TABLES 5-3 & 5-4.
  - 2 FENDER WASHER AND NUT. (TYP.)
  - 3 3/8", OR 1/2", OR 3/4" ALL THREAD ROD AS APPLICABLE. (TYP.)  
PER SMACNA SEISMIC GUIDELINES:  
- FOR DUCTWORK REFER TO TABLES 5-1, 5-2, 5-3, & 5-4.  
- FOR PIPE RACK REFER TO TABLES 5-7 & 5-8.
  - 4 VERTICAL STIFFENERS FOR 18" OR LONGER HANGER RODS PER SMACNA STANDARDS. REFER TO SMACNA SEISMIC GUIDELINES FIGURE 9-11. (TYP.)
  - 5 OPEN WEB TRUSS BOTTOM TREAD.
  - 6 1-5/8"x1-5/8"x1/4" THICK WASHER. UNISTRUT #P1063 FOR 3/8" ROD, OR #P1064 FOR 1/2" ROD, OR P2471 FOR 3/4" ROD, NUT AND LOCKNUT. (TYP.)
  - 7 FENDER WASHER, NUT AND LOCKNUT. (TYP.)
  - 8 1"x20 GA. GSM STRAP FOR DUCT SUPPORT ONLY.
  - 9 (2) #10 TEK SCREWS.
  - 10 12 GA. WIRE FOR FLEX DUCT AND REGISTER PLENUMS SUPPORT ONLY.

2 PIPE/DUCT RACK ATTACHMENT TO OPEN WEB TRUSS ROOF FRAMING  
- NTS

NOTE:  
REFERENCES TO MANUFACTURER'S NAME AND MODEL NUMBER ARE USED TO ESTABLISH A QUALITY STANDARD FOR THIS PROJECT. IT IS UNDERSTOOD THAT SUCH REFERENCES ARE USED TO FACILITATE THE DESCRIPTION OF THE PRODUCT AND IS DEEMED TO BE FOLLOWED BY THE WORDS " OR EQUAL"

3 HHW SYSTEM WATER TREATMENT UNIT DETAIL  
- NTS

NO.	DATE	REVISIONS
1	06/01/20	ISSUE FOR BID



SUBMITTED		Integrated Engineering Services 70 SARATOGA AVE. * SUITE 200 SANTA CLARA, CA. 95051-7301 PHONE: (408)261-3500 * FAX (408)261-4176 www.IEEngineering.net	
DESIGNED	TR	CHECKED	LC
DRAWN	HL	CADD FILE NAME	-



APPROVED	
CADD FILE DATE	SCALE
APRIL 15, 2020	NONE
PLOT DATE	BOARD APPROVAL DATE
-	-

CERONE DIVISION BOILER AND PROPANE TANK REPLACEMENT			SHEET 33
PLUMBING DETAILS			OF 49 DRAWING NO. P21
SAP NO.	CONTRACT NO. C19123	FILE LOCATION	REVISION 1



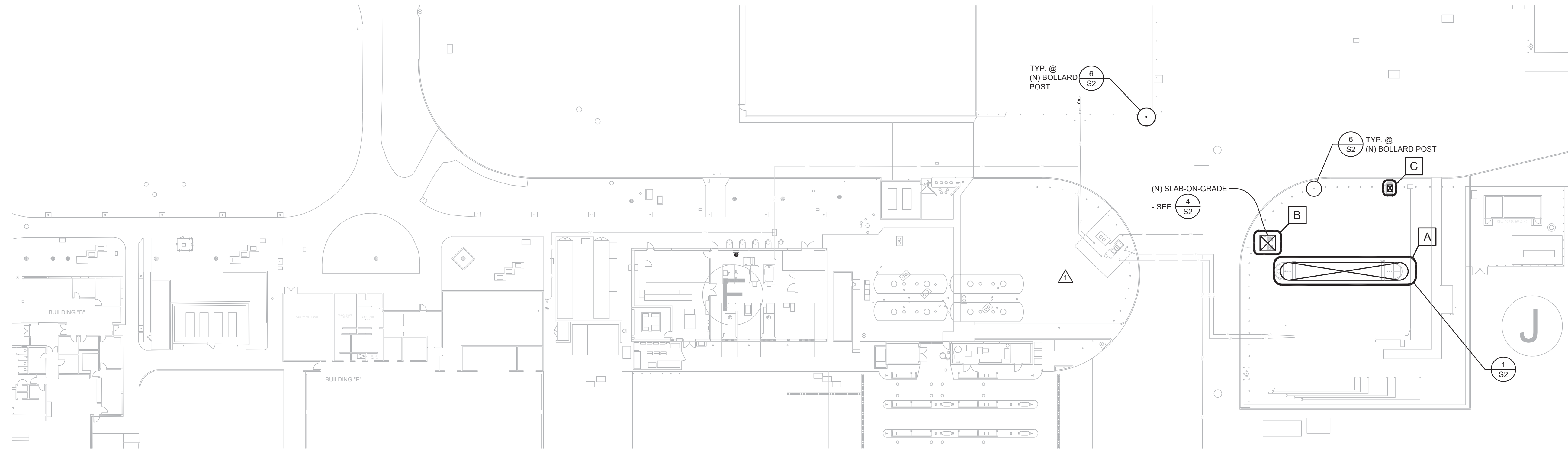

**PARTIAL SITE PLAN**  
1"=30'

PLUMBING SUPPORT ANCHORAGE		
PLUMBING DETAIL	ANCHOR	ANCHORAGE DETAIL
5 P18	3/8"Ø EXPANSION ANCHOR	3 S2
1 P21	3/8"Ø EXPANSION ANCHOR	3 S2

EQUIPMENT SCHEDULE								
ID	NAME	LOCATION	MAX. HT.	LENGTH	MIN. WIDTH	WEIGHT (LBS.)	FOUNDATION DETAIL	ANCHORAGE DETAIL
A	LPG TANK	YARD	9'-5"	66'-0"	9'-2"	174,000*	1 S2	2 S2
B	RH240 VAPORIZER	YARD	5'-0"	2'-9"	2'-6"	640	4 S2	8 S2
C	LIQUID TRANSFER SKID	YARD	-	-	-	-	-	10 S2

**GENERAL NOTES**

- (E) DENOTES EXISTING CONSTRUCTION  
(N) DENOTES NEW CONSTRUCTION  
(D) DENOTES DEMOLITION
- 20'-0"± DENOTES EXISTING DIMENSION  
4'-9" DENOTES DIMENSION OR WEIGHT TO BE VERIFIED BY CONTRACTOR
- SEE STRUCTURAL SPECIFICATIONS THIS SHEET
- CONTRACTOR SHALL VERIFY ALL CONTROLLING EXISTING CONDITIONS AND DIMENSIONS PRIOR TO BEGINNING CONSTRUCTION AND/OR ORDERING MATERIALS. ANY DISCREPANCIES SHALL BE BROUGHT TO THE ATTENTION OF VTA IMMEDIATELY.
- WEIGHTS OF EQUIPMENT SHOWN ON THE DRAWINGS ARE THE MAXIMUM WEIGHT ALLOWED INCLUDING ATTACHED ACCESSORIES.
- THE SIZE, LOCATION AND ORIENTATION OF ALL EQUIPMENT, SHALL BE VERIFIED BY THE CONTRACTOR. ANY CONFLICTS SHALL BE BROUGHT TO THE ATTENTION OF VTA IMMEDIATELY.
- SEE SITE PLAN AND EQUIPMENT SCHEDULE FOR EQUIPMENT ANCHORAGE

**STRUCTURAL SPECIFICATIONS**

**STRUCTURAL STEEL AND MISCELLANEOUS IRON**  
ASTM A992 FOR ALL W-SHAPES, A36 FOR ALL OTHER SHAPES, EXCEPT TUBE AND PIPE AND A572 GR. 50 FOR ALL PLATES, IN ACCORDANCE WITH AISC SPECIFICATIONS. ALL STRUCTURAL STEEL AND MISCELLANEOUS IRON SHALL RECEIVE SHOP PRIME COAT AND FINISH COAT PER TECHNICAL SPECIFICATION 09 91 23.

**UNISTRUT CHANNELS AND FITTINGS**  
UNISTRUT CHANNELS AND FITTINGS SHALL BE THOSE MANUFACTURED BY UNISTRUT CORPORATION, HARVEY, ILLINOIS, OR APPROVED EQUAL. INSTALLATION SHALL CONFORM TO MANUFACTURER'S RECOMMENDATIONS.

**EXPANSION ANCHORS**  
EXPANSION ANCHORS SHALL BE "KWIK BOLT TZ SS 304" AS MANUFACTURED BY HILTI, INC., TULSA, OKLAHOMA. PREPARATION OF HOLES AND INSTALLATION OF ANCHORS SHALL CONFORM TO MANUFACTURER'S RECOMMENDATIONS AND I.C.C. REPORT ESR-1917.

**MACHINE BOLTS**  
MACHINE BOLTS SHALL BE ASTM A307. HOLES IN STEEL SHALL BE 1/16" OVERSIZED U.N.O. HOLES IN COLUMN BASE PLATE FOR ANCHOR BOLTS MAY BE OVERSIZED PER TABLE 14-2 IN THE 14TH EDITION OF THE STEEL CONSTRUCTION MANUAL AS PUBLISHED BY AISC. PROVIDE MINIMUM WASHERS FOR OVERSIZED HOLES AS REQUIRED BY TABLE 14-2 U.N.O.

**ANCHOR BOLTS, ANCHOR RODS INSTALLED IN CONCRETE**  
HOOKED, HEADED, OR THREADED AND NUTTED ANCHOR RODS, AND ANCHOR BOLTS SHALL BE ASTM F1554 GR. 36. HIGH STRENGTH (H.S.) SHALL BE GR 105 (MIN.) USE NUTS MEETING STRENGTH REQUIREMENTS OF BOLTS & ANCHOR BOLTS. HOLES IN COLUMN BASE PLATE FOR ANCHOR BOLTS MAY BE OVERSIZED PER TABLE 14-2 IN THE 14TH EDITION OF THE STEEL CONSTRUCTION MANUAL AS PUBLISHED BY AISC. PROVIDE MINIMUM WASHERS FOR OVERSIZED HOLES AS REQUIRED BY TABLE 14-2 U.N.O. WHERE REQUIRED, ANCHOR BOLTS AND ANCHOR RODS SHALL BE GALVANIZED PER ASTM F2329.

**THREADED RODS**  
ASTM A36 MATERIAL MEETING THE MECHANICAL REQUIREMENTS OF ASTM A307. ASTM F1554, GR 105, WHERE H.S. THREADED RODS IS SPECIFIED ON DRAWINGS.

**CONCRETE**  
ALL CONCRETE SHALL HAVE PROPERTIES AS LISTED BELOW. MAXIMUM WATER-CEMENT RATIO, BY WEIGHT SHALL BE 0.55. CONCRETE SHALL HAVE A 28 DAY TOTAL DRYING SHRINKAGE OF LESS THAN 0.032%.

AT CONTRACTOR'S OPTION, APPROXIMATELY 4 OUNCES PER 100 POUNDS OF CEMENT OF "MASTERSSET R 300" BY BASF CORPORATION OR APPROVED EQUAL SHALL BE USED AS A WATER DISPERSING ADDITIVE. TO PROVIDE THE REQUIRED AIR CONTENT, THE CONTRACTOR MAY ADD AN AIR ENTRAINING AGENT CONFORMING TO THE LATEST REVISION OF ASTM SPECIFICATIONS C260 TO THE CONCRETE MIX.

CONCRETE ELEMENT	MIN. 28 DAY COMPRESSIVE STRENGTH (psi)	MAX. AGGREGATE SIZE	MAX. SLUMP (INCHES)	TOTAL AIR CONTENT
SLABS ON GRADE (ONLY THOSE DETAILED IN THE STRUCTURAL DRAWINGS)	2500	3/4"	3"	3-4%
FOOTINGS PER DETAIL	3000	3/4"	3"	3-4%

MAINTAIN CONCRETE IN A MOIST CONDITION FOR A SUITABLE PERIOD AFTER PLACEMENT IN ACCORDANCE WITH ACI 301, SECTION 5. CEMENT SHALL BE TYPE II AND CONFORM TO ASTM C150. AGGREGATE SHALL CONFORM TO ASTM C33.

\* MIX DESIGN SHALL NOT CONTAIN CHLORIDES AND SHALL BE PROPORTIONED WITH 15% SUPPLEMENTARY CEMENTITIOUS MATERIAL PER WEIGHT OF TOTAL CEMENTITIOUS MATERIAL. MAXIMUM WATER-CEMENT RATIO BY WEIGHT SHALL BE 0.50. SEE ALSO POST-TENSIONING NOTES THIS SHEET.

**REINFORCING STEEL**  
BARS FOR REINFORCING SHALL BE GRADE 60 DEFORMED BARS CONFORMING TO ASTM A615 INCLUDING SUPPLEMENTS. WHERE REINFORCING STEEL IS SHOWN TO BE WELDED, BARS SHALL CONFORM TO ASTM A706. LAP SPLICES SHALL BE CLASS B U.N.O. IN ACCORDANCE WITH ACI 318-14. STANDARD HOOKS SHALL BE IN ACCORDANCE WITH ACI 318-14.

VERTICAL REINFORCEMENT FOR COLUMNS SHALL CONFORM TO ASTM A706 (MEMBERS NOT PART OF THE LATERAL FORCE RESISTING SYSTEM) OR SHALL MEET THE FOLLOWING REQUIREMENTS:  
1. THE ACTUAL YIELD STRENGTH BASE ON MILL TESTS SHALL NOT EXCEED THE SPECIFIED YIELD STRENGTH BY MORE THAN 18,000 psi.  
2. THE RATIO OF THE ACTUAL ULTIMATE TENSILE STRENGTH TO THE ACTUAL YIELD STRENGTH SHALL NOT BE LESS THAN 1.25.

**SUBMITTALS**  
SUBMITTALS PER DIVISION 3 OF TECHNICAL SPECIFICATIONS.

**SPECIAL INSPECTIONS**  
CONTRACTOR EMPLOY A SPECIAL INSPECTOR & INDEPENDENT TESTING AGENCY AT CONTRACTOR EXPENSE DURING CONSTRUCTION ON THE FOLLOWING PHASE OF WORK:

**EXPANSION ANCHORS**  
DURING INSTALLATION OF EXPANSION BOLTS TO VERIFY ANCHOR TYPE, ANCHOR DIMENSIONS, CONCRETE TYPE, DRILL-BIT TYPE, HOLE DIMENSIONS, HOLE CLEANING PROCEDURE, ANCHOR SPACING, EDGE DISTANCES, CONCRETE MEMBER THICKNESS, ANCHOR EMBEDMENT, TIGHTENING TORQUE AND ADHERENCE TO THE MANUFACTURER'S PUBLISHED INSTALLATION INSTRUCTIONS.

**CONCRETE**  
DURING TIME FRESH CONCRETE IS SAMPLED TO FABRICATE SPECIMENS FOR STRENGTH TESTS, PERFORMANCE OF SLUMP AND AIR CONTENT TESTS, AND DETERMINATION OF CONCRETE TEMPERATURE.  
INSPECTION OF CONCRETE PLACEMENT FOR PROPER APPLICATION TECHNIQUES.

- EXCEPTIONS:**
- STRUCTURAL DESIGN OF FOOTING IS BASED ON A SPECIFIED COMPRESSIVE STRENGTH (f<sub>c</sub>) NO GREATER THAN 2,500 PSI.
  - NONSTRUCTURAL CONCRETE SLABS SUPPORTED DIRECTLY ON EARTH WHERE NO SPECIAL HAZARD EXISTS.
  - SPECIAL INSPECTIONS PER TECHNICAL SPECIFICATIONS.

**SPECIAL INSPECTOR AND TESTING AGENCY**  
EACH SPECIAL INSPECTOR (SI) OR TESTING AGENCY (TA) SHALL BE APPROVED BY VTA PRIOR TO PERFORMING ANY INSPECTION OR TESTING DUTIES. IN ORDER TO BE CONSIDERED FOR APPROVAL EACH SI OR TA SHALL SUBMIT RESUME(S) ALONG WITH AT LEAST TWO PROFESSIONAL REFERENCES DESCRIBING QUALIFICATIONS AND EXPERIENCE TO PERFORM SPECIAL INSPECTION OR TESTING SERVICES.

**DUTIES AND RESPONSIBILITIES OF THE SPECIAL INSPECTOR**

- THE SPECIAL INSPECTOR SHALL OBSERVE THE WORK ASSIGNED FOR CONFORMANCE WITH THE APPROVED DESIGN DRAWINGS AND SPECIFICATIONS.
- THE SPECIAL INSPECTOR SHALL FURNISH INSPECTION REPORTS TO VTA. ALL DISCREPANCIES SHALL BE BROUGHT TO THE IMMEDIATE ATTENTION OF THE CONTRACTOR FOR CORRECTION, THEN, IF UNCORRECTED, TO THE PROPER DESIGN AUTHORITY AND TO VTA.
- THE SPECIAL INSPECTOR SHALL SUBMIT A FINAL SIGNED REPORT STATING WHETHER THE WORK REQUIRING SPECIAL INSPECTION WAS, TO THE BEST OF THE INSPECTOR'S KNOWLEDGE, IN CONFORMANCE WITH THE APPROVED PLANS AND SPECIFICATIONS AND THE APPLICABLE WORKMANSHIP PROVISIONS OF THE CODE.



**PEOPLES ASSOCIATES**  
 STRUCTURAL ENGINEERS  
 408-957-9220 • www.pase.com  
 San Jose, California • Pleasanton, California  
 DESIGNED: PVC  
 CHECKED:  
 DRAWN:  
 CADD FILE NAME:



APPROVED  
 CADD FILE DATE: JULY 7, 2018  
 PLOT DATE: JUNE 01, 2020  
 SCALE:  
 BOARD APPROVAL DATE:

**CERONE DIVISION**  
**BOILER AND PROPANE TANK**  
**REPLACEMENT**  
**PARTIAL SITE PLAN**  
 SHEET 34 OF 49 DRAWING NO. S1 REVISION 1  
 SAP NO. CONTRACT NO. C19123 FILE LOCATION

NO.	DATE	REVISIONS
1	06-01-20	ISSUE FOR BID



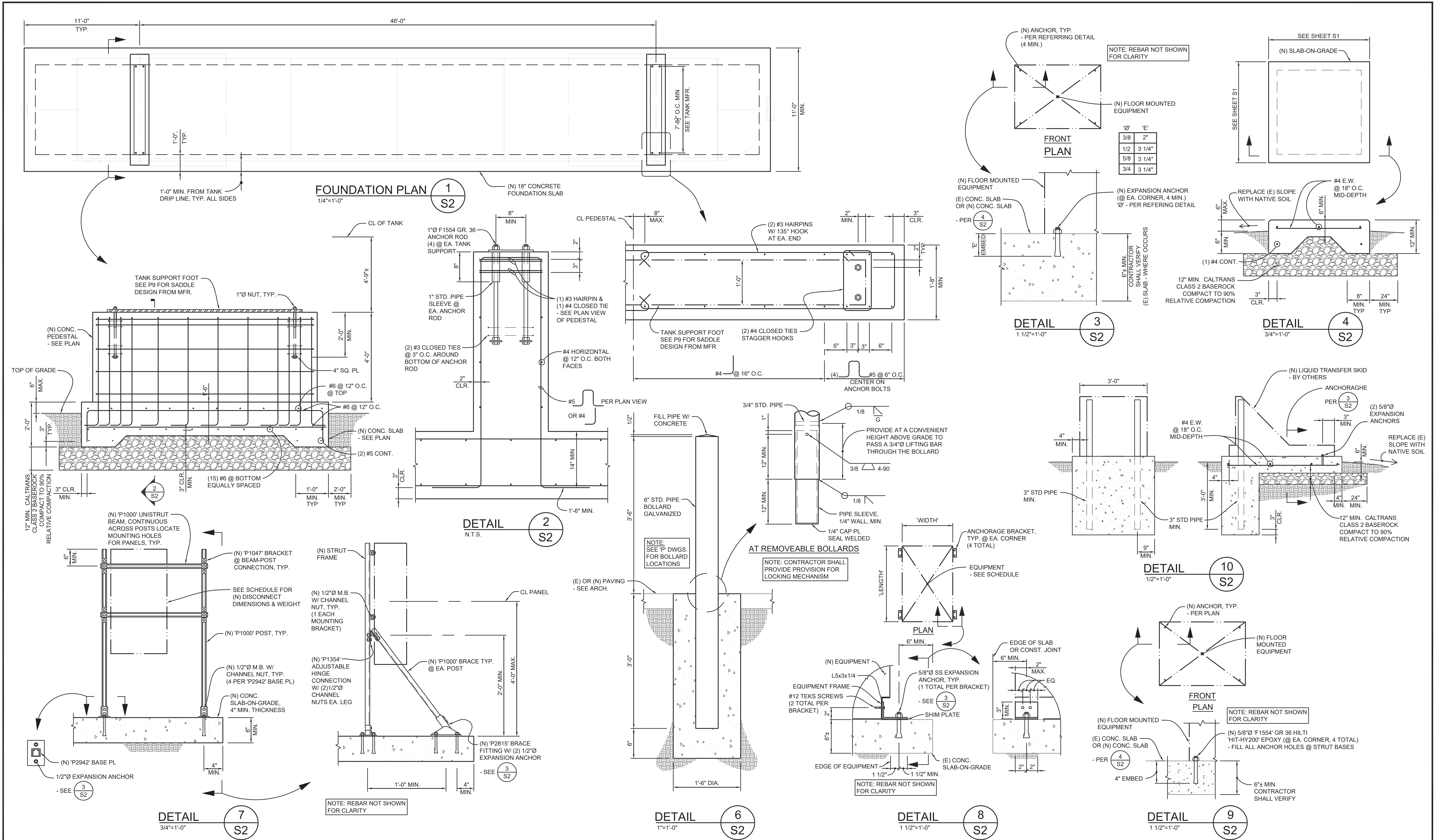

SUBMITTED

**PEOPLES ASSOCIATES**  
STRUCTURAL ENGINEERS

408-957-9220 www.pase.com  
San Jose, California Pleasanton, California

DESIGNED PVC CHECKED  
DRAWN CADD FILE NAME



APPROVED

CADD FILE DATE: JULY 7, 2018  
SCALE

PLOT DATE: JUNE 01, 2020  
BOARD APPROVAL DATE

CERONE DIVISION  
BOILER AND PROPANE TANK  
REPLACEMENT

STRUCTURAL DETAILS

SHEET 35 OF 49 DRAWING NO. S2 REVISION 1

SAP NO. CONTRACT NO. C19123 FILE LOCATION

NO.	DATE	REVISIONS
1	06-01-20	ISSUE FOR BID



U:\18024.01 (VTA BOILER TANK DESCOPE)\DWGS\8024-E1.dwg, 6/1/2020 1:53:17 PM, CORTEGA

**GENERAL NOTES**

- ALL WORK SHALL COMPLY WITH CURRENT NEC, OSHA AND LOCAL CODES AND REGULATIONS. 2016 CALIFORNIA ELECTRICAL CODE AND 2016 CALIFORNIA ENERGY CODE.
- ALL MATERIALS SHALL BE NEW AND UL LISTED AND INDUSTRIAL GRADE.
- PROVIDE A GREEN INSULATED GROUND WIRE IN ALL CONDUIT. SIZE SHALL BE IN ACCORDANCE WITH NEC TABLE 250 UNLESS SHOWN OTHERWISE ON DRAWINGS. THE GROUND WIRE SHALL BE PROVIDED IN ADDITION TO THE CONDUCTORS SHOWN BY CROSS HATCHES.
- ALL NEW RACEWAYS AND CONDUCTORS SHALL BE INSTALLED CONCEALED WHERE POSSIBLE.
- PRIOR TO ROUGH-IN ELECTRICAL WORK, COORDINATE ALL WORK WITH ALL TRADES INCLUDING EXISTING FACILITIES TO AVOID CONFLICT DURING CONSTRUCTION.
- IN ALL AREAS WHERE FIRE RATED WALLS, FLOOR OR CEILINGS ARE INSTALLED, ALL PENETRATIONS OF ELECTRICAL CONDUITS OR OTHER RELATED ELECTRICAL MATERIAL SHALL BE PROPERLY SEALED WITH U.L. LABELED OR LISTED FIRE RATED MATERIALS TO MAINTAIN RATING OF THE BUILDING. ALL PENETRATION SEALS SHALL COMPLY WITH THE LATEST EDITION OF THE U.L. FIRE RESISTANCE DIRECTORY. SEE ARCHITECTURAL SPECIFICATIONS AND DRAWINGS FOR ADDITIONAL REQUIREMENTS.
- REFER TO CIVIL, PLUMBING, MECHANICAL AND STRUCTURAL DRAWINGS PRIOR TO ROUGH-IN AND FINAL PLACEMENT OF ALL EQUIPMENT AND RACEWAYS. COORDINATE FINAL LOCATIONS, ELECTRICAL DEVICES AND FACEPLATE COLOR WITH VTA BEFORE INSTALLATION.
- PROVIDE UPDATED PANEL BOARD SCHEDULES FOR (E) PANELS BEING MODIFIED AND THE NEW PANELS.
- ALL RECEPTACLES OF 30-AMPERES OR LESS SHALL NOT BE INSTALLED AT MORE THAN 48 INCHES MAXIMUM AFF, MEASURED FROM TOP OF THE OUTLET BOX NOR LESS THAN 15 INCHES MINIMUM AFF, MEASURED FROM THE BOTTOM OF THE OUTLET BOX AS PER CBC 11B-308.1 (DOES NOT APPLY TO RECEPTACLES NOT INTENDED FOR USE BY BUILDING OCCUPANTS, SEE DRAWINGS.).
- ALL SWITCHES SHALL BE AT MAXIMUM ELEVATION OF 48 INCHES MAXIMUM AFF, MEASURED FROM THE BOTTOM OF THE OUTLET BOX AS PER CBC 11B-308.1.
- CONTRACTOR MUST SUBMIT DETAILED SHOP DRAWINGS OF ALL EQUIPMENT AND MATERIAL PRIOR TO FABRICATION.
- ANY PORTION OF EXISTING WORK WHICH MAY BE DISTURBED OR DAMAGED WHERE NEW WORK OCCURS SHALL BE RESTORED TO A CONDITION AS GOOD AS BEFORE THE COMMENCEMENT OF THE WORK.
- VTA RESERVES THE RIGHT TO MOVE DEVICES WITHIN 10' AS SHOWN AT THE TIME OF ROUGH-IN AND PRIOR TO COMPLETE INSTALLATION WITH NO ADDITIONAL COST TO VTA.

**SYMBOL LIST**

(NOTE: NOT ALL SYMBOLS ARE APPLICABLE ON THIS PROJECT)

CEILING	WALL		
		INCANDESCENT, PL FLUORESCENT OR LED. LIGHTING OUTLET AND FIXTURE	
		PARKING OR ROADWAY ELECTROLIER WITH SINGLE LUMINAIRE	
		WIRES IN CONDUIT, CONCEALED ABOVE CEILING OR IN WALLS.	
		WIRES IN CONDUIT, CONCEALED UNDER FLOOR OR UNDERGROUND.	
		HOMERUN OF CONDUIT AND WIRES TO CIRCUIT #1 IN PANEL "A"	
		CROSS HATCHES INDICATE NO. OF #12 AWG WIRES IN CONDUIT IN ADDITION TO #12 AWG GROUND, IF MORE THAN 2 #12.	
		(E) CONDUIT AND CONDUCTORS TO BE DISCONNECTED AND REMOVED	
		CONDUIT STUB OUT	
		FLEXIBLE CONDUIT	
		CONDUIT UP	
		CONDUIT DOWN	
		GROUND WIRE, SIZE AS INDICATED	
		SURFACE METAL RACEWAY, SIZE AS SHOWN	
		DISTRIBUTION PANEL, SURFACE MOUNTED	
		BRANCH CIRCUIT PANEL, SURFACE OR FLUSH MOUNTED	
		TERMINAL OR CONTROL CABINET, SURFACE OR FLUSH MOUNTED	
		SINGLE POLE SWITCH, LOWERCASE LETTER INDICATES ASSOCIATED LIGHT FIXTURE	
		DIMMER SWITCH, RATING AS SHOWN	
		SWITCH WITH PILOT LIGHT	
		THERMAL TRIP SWITCH	
		DUPLEX RECEPTACLE, NUMBER AND LETTER INDICATE ASSOCIATED CIRCUIT AND SWITCH.	
		DUPLEX RECEPTACLE ON UPS POWER, ORANGE IN COLOR.	
		TWO DUPLEX RECEPTACLES MOUNTED IN ONE 2 GANG BOX	
		DUPLEX RECEPTACLE ON EMERGENCY CIRCUIT.	
		SPECIAL PURPOSE RECEPTACLE, TYPE AS SHOWN.	
		JUNCTION BOX	
		SAFETY DISCONNECT SWITCH	
		COMBINATION MOTOR CIRCUIT PROTECTOR (MCP) AND MOTOR STARTER	
		EMERGENCY SHUT-OFF SWITCH FOR PROPANE	
		TRANSFORMER FLOOR MOUNTED U.O.N.	
		SHEET NOTE REFERENCE MARKER, NOTE #1 SHOWN	
		REVISION REFERENCE MARKER	
		DETAIL REFERENCE MARKER, DETAIL #1 ON SHEET E6.1 SHOWN	
		MECHANICAL EQUIPMENT DESIGNATION	
		TYPICAL LIGHTING FIXTURE DESIGNATION, FIXTURE TYPE "A" SHOWN	

NOTE:  
ALL EQUIPMENT AND DEVICE LOCATIONS SHALL BE COORDINATED IN THE FIELD WITH ALL OTHER TRADES AND EXISTING CONDITION PRIOR TO ROUGH-IN.

**DRAWING INDEX**

E1	ELECTRICAL – SYMBOLS, ABBREV., INDEX AND NOTES
E2	ELECTRICAL – SINGLE LINE DIAGRAM
E3	ELECTRICAL – TITLE 24 POWER DIST. COMPLIANCE FORMS
E4	ELECTRICAL – SITE PLAN OVERALL
<del>E5</del>	<del>ELECTRICAL – PLAN AREA 1 (NOT USED)</del>
E6	ELECTRICAL – PLAN AREA 2
E7	ELECTRICAL – PLAN AREA 3
E8	ELECTRICAL – PLAN AREA 4
E9	ELECTRICAL – PANEL SCHEDULES
E10	ELECTRICAL – DETAILS

**ABBREVIATIONS**

A	AMPERE	NIC	NOT IN CONTRACT
A.F.F.	ABOVE FINISHED FLOOR	N.O.	NORMALLY OPEN
A/G	ABOVE GROUND	NTS	NOT TO SCALE
ATS	AUTOMATIC TRANSFER SWITCH		OHM
C	CONDUIT	PNL	PANEL
CAB	CABINET	$\emptyset, ph$	PHASE
$\emptyset, CIR$	CIRCUIT	(RL)	RELOCATED
CB	CIRCUIT BREAKER	SW	SWITCH
COMM	COMMUNICATION	SWBD	SWITCHBOARD
(E),EXIST	EXISTING	TYP.	TYPICAL
(F),FUT	FUTURE	UON	UNLESS OTHERWISE NOTED
(G),GRD	GROUND	U/G	UNDER GROUND
HH	HANDHOLE	V	VOLT
Hz	HERTZ	VA	VOLTAMPERE
JB	JUNCTION BOX	W	WATT
KVA	KILOVOLTAMPERE	WP	WEATHERPROOF (DEVICE OR ENCLOSURE)
KW	KILOWATT	A-1,3,5	TYPICAL HOMERUN DESIGNATION TO CIRCUITS 1,3,5 IN PANEL 'A'.
MCC	MOTOR CONTROL CENTER	A-(1,3,5)	TYPICAL HOMERUN DESIGNATION TO 3-POLE CIRCUIT BREAKER IN PANEL 'A'.
(N)	NEW		
N.C.	NORMALLY CLOSED		

No.	DATE	REVISIONS
1	01/30/20	ISSUED FOR BID

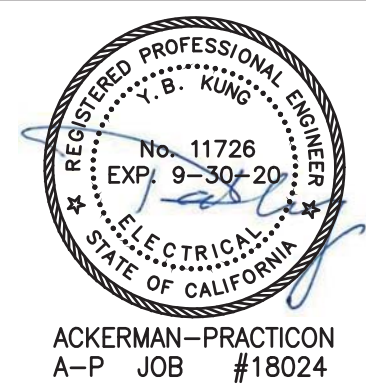

**ACKERMAN PRACTICON**  
CONSOLIDATED TECHNICAL SERVICES  
801 E. CHARLESTON ROAD PALO ALTO, CA 94303  
650 . 965 . 1000 FAX: 650 . 494 . 9312  
A-P PROJECT NUMBER: 18024

DESIGNED	EO	CHECKED	DK
DRAWN	CO	CADD FILE NAME	8024-E1.dwg



APPROVED	
CADD FILE DATE	SCALE
JULY 01, 2018	AS NOTED
PLOT DATE	BOARD APPROVAL DATE
-	-

**CERONE DIVISION  
BOILER AND PROPANE TANK  
REPLACEMENT**

**ELECTRICAL  
SYMBOLS, ABBREV., INDEX, NOTES**

SAP NO.	CONTRACT NO.	FILE LOCATION
	C19123	

SHEET	36
OF 49	
DRAWING NO.	E1
REVISION	1

U:\18024.01 (VTA BOILER TANK DESCOPE)\DWGS\8024-E2.dwg, 6/2/2020 3:31:19 PM, Carlos

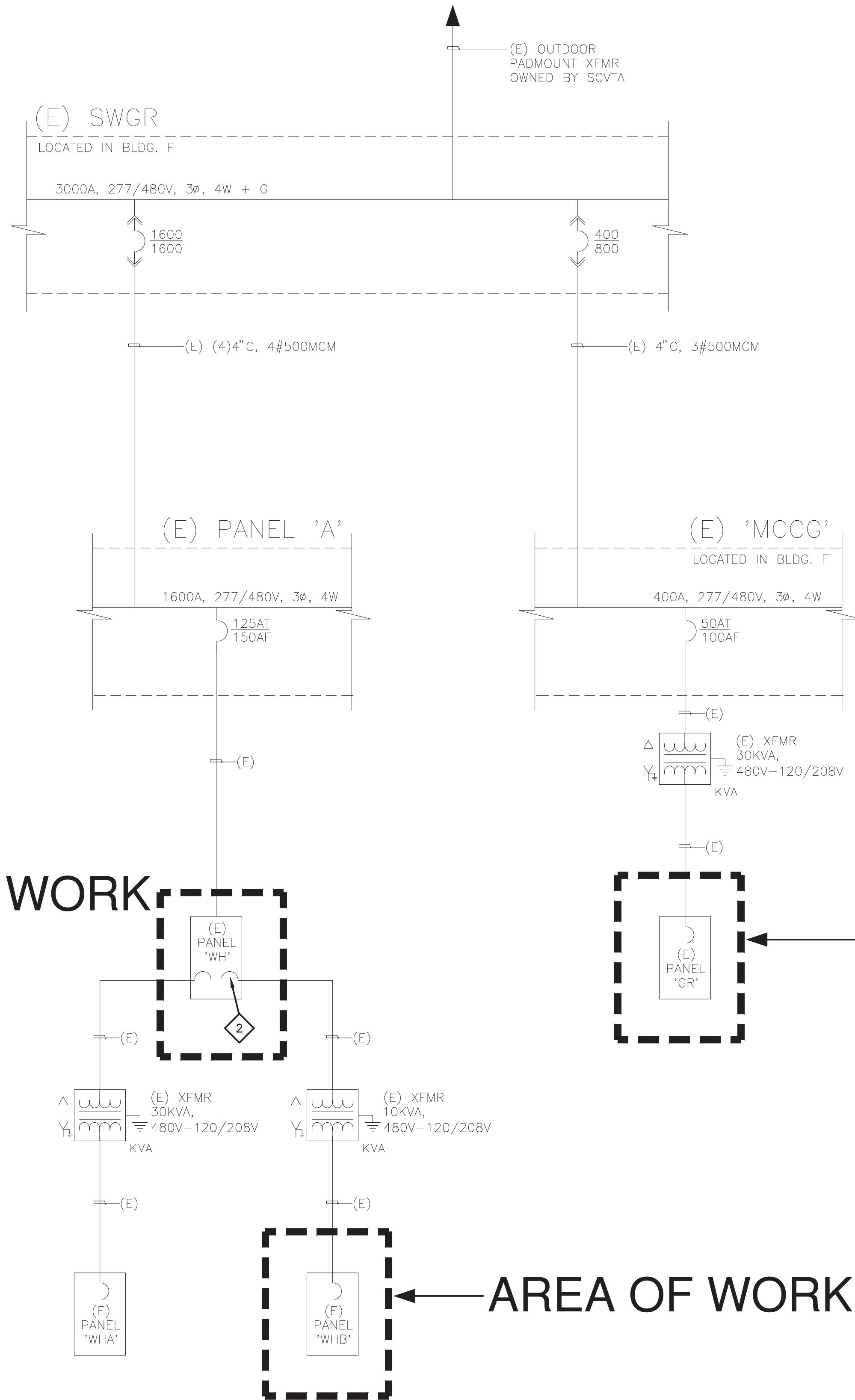

AREA OF WORK

AREA OF WORK 1

AREA OF WORK 1 3

**GENERAL NOTES:**

- A. SEE GENERAL NOTES ON DRAWING E6 FOR MORE INFORMATION.
- B. ALL NEW PANELS SHALL MATCH EXISTING INCLUDING THE NEW CIRCUIT BREAKERS.

**SHEET NOTES:**

- 1 SEE PANEL SCHEDULES ON DRAWING E9 FOR MORE INFORMATION.
- 2 PROVIDE CIRCUIT BREAKER WITH RED PADLOCK LOCK-OUT DEVICE AND WARNING LABEL.
- 3 AT CIRCUIT NO.6 PROVIDE CIRCUIT BREAKER WITH RED PADLOCK LOCK-OUT DEVICE AND WARNING LABEL AS SHOWN ON SHEET E9 PANEL SCHEDULE.

No.	DATE	REVISIONS
1	01/30/20	ISSUED FOR BID



**ACKERMAN PRACTICON**  
CONSOLIDATED TECHNICAL SERVICES  
801 E. CHARLESTON ROAD PALO ALTO, CA 94303  
650 . 965 . 1000 FAX: 650 . 494 . 9312  
A-P PROJECT NUMBER: 18024

DESIGNED: EO  
DRAWN: CO

CHECKED: DK  
CADD FILE NAME: 8024-E2.dwg



APPROVED

CADD FILE DATE JULY 01, 2018	SCALE AS NOTED
PLOT DATE -	BOARD APPROVAL DATE -

CERONE DIVISION BOILER AND PROPANE TANK REPLACEMENT		SHEET OF 49 DRAWING NO. <b>E2</b>
		REVISION 1
SAP NO.	CONTRACT NO. C19123	FILE LOCATION



U:\18024.01 (VTA BOILER TANK DESCOPE)\DWGS\8024-E3.dwg, 6/1/2020 1:53:21 PM, CORTEGA

STATE OF CALIFORNIA  
**Electrical Power Distribution**  
 CERTIFICATE OF COMPLIANCE  
 Electrical Power Distribution (Page 3 of 6)  
 Project Name: VTA CERONE DIVISION BOILER AND PROPANE TANK REPLACEMENT Date Prepared: 12/12/2019

**A. Service Electrical Metering**  
 Check one of the three boxes below if the electrical power distribution system is in compliance with Section 130.5(a).  
 For newly installed electrical service in newly constructed buildings, Service Electrical Metering is required according to Section 130.5(a). Fill out Column 1 thru 6 of table below.  
 For new or replacement electrical service equipment in existing buildings, Service Electrical Metering is required according to Section 141.0(b)(2)(F). Fill out Column 2 thru 6 of table below.  
 EXCEPTION to Electrical Service Metering: Service or feeder for which the utility company provides a metering system that indicates instantaneous kW demand and kWh for a utility-defined period. Fill out Column 1, 2 and 6 of table below with the compliance information.

Fill out a separate line for each electrical service that is connected to the building. If additional table space is needed for electrical service information, submit additional page with the information.

Electrical Service Schedule	Electrical Service Rating	Metering Capabilities (check all that are present)				Exception to 130.5(a)	Field Inspector
01	02	03	04	05	06	07	08
Electrical Service Designation/Location/Description	kVA	Instantaneous kW	Historical peak (kW)	Tracing kWh	Utility metering system		Check that the metering complies
N/A		<input type="checkbox"/>	<input type="checkbox"/>	<input type="checkbox"/>	<input type="checkbox"/>	<input type="checkbox"/>	<input type="checkbox"/>
		<input type="checkbox"/>	<input type="checkbox"/>	<input type="checkbox"/>	<input type="checkbox"/>	<input type="checkbox"/>	<input type="checkbox"/>

CA Building Energy Efficiency Standards - 2016 Nonresidential Compliance January 2016

STATE OF CALIFORNIA  
**Electrical Power Distribution**  
 CERTIFICATE OF COMPLIANCE  
 Electrical Power Distribution (Page 2 of 6)  
 Project Name: VTA CERONE DIVISION BOILER AND PROPANE TANK REPLACEMENT Date Prepared: 12/12/2019

Document Number	Document Title / Descriptions (Include description information for Table or Schedule if it contains compliance information)	Document Sheet # or Page #	Applicable subsection of Section 130.5
N/A			

CA Building Energy Efficiency Standards - 2016 Nonresidential Compliance January 2016

STATE OF CALIFORNIA  
**Electrical Power Distribution**  
 CERTIFICATE OF COMPLIANCE  
 Electrical Power Distribution (Page 1 of 6)  
 Project Name: VTA CERONE DIVISION BOILER AND PROPANE TANK REPLACEMENT Date Prepared: 12/12/2019

**General Information**  
 Project Address: 3990 ZANKER ROAD Climate Zone: 4  
 Building Type:  Nonresidential  Schools  High-Rise Residential  Hotel/Motel  Relocatable Public Schools  
 Phase of Construction:  New Construction  Addition  Alteration

In the table below identify all applicable construction documents that specify the requirements for the scope of responsibility reported by this certificate. Use additional pages as needed to list all construction documents related to compliance of Section 130.5.

Document Number	Document Title / Descriptions (Include description information for Table or Schedule if it contains compliance information)	Document Sheet # or Page #	Indicate which subsection of Section 130.5 is related to the document (e.g. 130.5(a) for service electrical metering)
N/A			

CA Building Energy Efficiency Standards - 2016 Nonresidential Compliance January 2016

STATE OF CALIFORNIA  
**Electrical Power Distribution**  
 CERTIFICATE OF COMPLIANCE  
 Electrical Power Distribution (Page 6 of 6)  
 Project Name: VTA CERONE DIVISION BOILER AND PROPANE TANK REPLACEMENT Date Prepared: 12/12/2019

**DOCUMENTATION AUTHOR'S DECLARATION STATEMENT**  
 I certify that this Certificate of Compliance documentation is accurate and complete.  
 Documentation Author Name: Brian K. Shaw  
 Company: Ackerman-Practicon  
 Address: 801 E. CHARLESTON ROAD  
 City/State/Zip: PALO ALTO, CA 94303  
 Signature Date: 12/12/2019  
 CRA/HERS Certification Identification (if applicable):  
 Phone: (650)965-1000

**RESPONSIBLE PERSON'S DECLARATION STATEMENT**  
 I certify the following under penalty of perjury, under the laws of the State of California:  
 1. The information provided on this Certificate of Compliance is true and correct.  
 2. I am eligible under Division 3 of the Business and Professions Code to accept responsibility for the building design or system design identified on this Certificate of Compliance (responsible designer).  
 3. The energy features and performance specifications, materials, components, and manufactured devices for the building design or system design identified on this Certificate of Compliance conform to the requirements of Title 24, Part 1 and Part 6 of the California Code of Regulations.  
 4. The building design features or system design features identified on this Certificate of Compliance are consistent with the information provided on other applicable compliance documents, worksheets, calculations, plans and specifications submitted to the enforcement agency for approval with this building permit application.  
 5. I will ensure that a completed signed copy of this Certificate of Compliance shall be made available with the building permit(s) issued for the building, and made available to the enforcement agency for all applicable inspections. I understand that a completed signed copy of this Certificate of Compliance is required to be included with the documentation the builder provides to the building owner at occupancy.

Responsible Designer Name: DAVID KLING  
 Company: ACKERMAN-PRACTICON  
 Address: 801 E. CHARLESTON ROAD  
 City/State/Zip: PALO ALTO, CA 94080  
 Date Signed: 8/20/2019  
 License: 11726  
 Phone: (650)965-1000

CA Building Energy Efficiency Standards - 2016 Nonresidential Compliance January 2016

STATE OF CALIFORNIA  
**Electrical Power Distribution**  
 CERTIFICATE OF COMPLIANCE  
 Electrical Power Distribution (Page 5 of 6)  
 Project Name: VTA CERONE DIVISION BOILER AND PROPANE TANK REPLACEMENT Date Prepared: 12/12/2019

**C. Voltage Drop**  
 Check all boxes below if the electrical power distribution system is in compliance with Section 130.5(c).  
 The electrical power distribution system meets the voltage drop requirement of Section 130.5(c). The maximum combined voltage drop on feeder conductors and branch circuit conductors to the farthest connected load or outlet, do not exceed 5%.  
 Voltage drop calculation documents showing compliance to Section 130.5(c) are submitted as part of the compliance document submittal.

**D. Circuit Controls for 120-Volt Receptacles and Controlled Receptacles**  
 Check one or more boxes below for applicable requirements of Section 130.5(d) for the electrical power distribution system.  
 The control is capable of automatically shutting OFF the controlled receptacles when the space is typically unoccupied, either at the receptacle or circuit level. For the automatic time switch control, it incorporates an override control that allows the controlled receptacle to remain ON for no more than 2 hours when an override is initiated and an automatic holiday "shut OFF" feature that turns OFF all loads for at least 24 hours and then resumes the normally scheduled operation. Countdown timer switches are not used to comply with the automatic time switch control requirements. The controls meet the requirement of Section 130.5(d)1.  
 There is at least one controlled receptacle within 6 ft from each uncontrolled receptacle. Where receptacles are installed in modular furniture in open office area, at least one controlled receptacle is installed at each workstation. The receptacles meet the requirement of Section 130.5(d)2.  
 There are installed split wired receptacles with at least one controlled and one uncontrolled receptacle. Where receptacles are installed in modular furniture in open office area, at least one controlled receptacle is installed at each workstation. The receptacles meet the requirement of Section 130.5(d)2.  
 Permanent and durable marking for controlled receptacles or circuits to differentiate them from uncontrolled receptacles or circuits is provided. The markings meet the requirement of Section 130.5(d)3.  
 For hotel and motel guest rooms, there are controlled receptacles for at least one-half of the 120-volt receptacles in each guest room. Electric circuits serving controlled receptacles in guestrooms are installed to have captive key controls, occupancy sensing controls, or automatic controls so the power is switched off no longer than 30 minutes after the guest room has been vacated. The receptacles meet the requirement of Section 130.5(d)4.  
 Receptacles that are only for the following purposes are excepted from Section 130.5(d):  
 -Receptacles specifically for refrigerators and water dispensers in kitchen areas.  
 -Receptacles located a minimum of six feet above the floor that are specifically for clocks.  
 -Receptacles for network copiers, fax machines, A/V and data equipment other than personal computers in copy rooms.  
 -Receptacles on circuits rated more than 20 amperes.  
 -Receptacles connected to an uninterruptible power supply (UPS) that are intended to be in continuous use, 24 hours per day/365 days per year, and are marked to differentiate them from other uncontrolled receptacles or circuits.

Enforcement Agency  
 Check that the system complies

Field Inspector  
 Check that the system complies

CA Building Energy Efficiency Standards - 2016 Nonresidential Compliance January 2016

STATE OF CALIFORNIA  
**Electrical Power Distribution**  
 CERTIFICATE OF COMPLIANCE  
 Electrical Power Distribution (Page 4 of 6)  
 Project Name: VTA CERONE DIVISION BOILER AND PROPANE TANK REPLACEMENT Date Prepared: 12/12/2019

**B. Separation of Electrical Circuits for Electrical Energy Monitoring**  
 Check all boxes below if the electrical power distribution system is in compliance with Section 130.5(b).  
 The electrical power distribution system meets the separation of electrical circuits for electrical energy monitoring requirement of Section 130.5(b). The electrical power distribution system is designed so that measurement devices can monitor the electrical energy usage of load types according to TABLE 130.5-B.  
 Describe the electrical power distribution system installed and the compliance method chosen in meeting the requirement of Section 130.5(b). Use the space below to include the information. Examples of compliance methods are detailed in Nonresidential Compliance Manual Chapter 8.

Fill out Column 1 thru 3 with the compliance information.

General Information	Electrical Power Distribution System Information and Method of Compliance	Electrical Service Rating	Enforcement Agency
01	02	03	04
Electrical Service Designation/Location/Description	Describe the electrical power distribution system installed and the compliance method used.	kVA	Check that the system complies
N/A			<input type="checkbox"/>
			<input type="checkbox"/>
			<input type="checkbox"/>
			<input type="checkbox"/>

Field Inspector Notes:  
 \_\_\_\_\_  
 \_\_\_\_\_  
 \_\_\_\_\_

CA Building Energy Efficiency Standards - 2016 Nonresidential Compliance January 2016

NO.	DATE	REVISIONS
1	01/30/20	ISSUED FOR BID

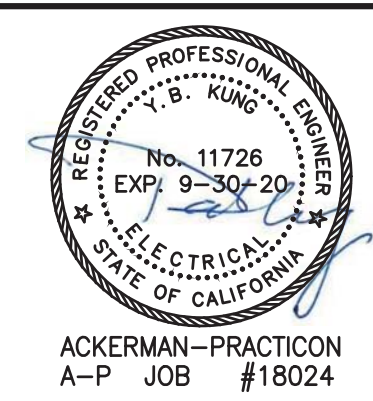

**ACKERMAN PRACTICON**  
 CONSOLIDATED TECHNICAL SERVICES  
 801 E. CHARLESTON ROAD PALO ALTO, CA 94303  
 650.965.1000 FAX: 650.494.9312  
 A-P PROJECT NUMBER: 18024

DESIGNED	EO	CHECKED	DK
DRAWN	CO	CADD FILE NAME	8024-E5.dwg



APPROVED

CADD FILE DATE	SCALE
JULY 01, 2018	AS NOTED
PLOT DATE	BOARD APPROVAL DATE
-	-

**CERONE DIVISION BOILER AND PROPANE TANK REPLACEMENT**  
**ELECTRICAL - TITLE 24 POWER DIST. COMPLIANCE FORMS**

SAP NO.	CONTRACT NO. C19123	FILE LOCATION
---------	---------------------	---------------

SHEET 40  
 OF 49  
 DRAWING NO. E3  
 REVISION 1



U:\18024.01 (VTA BOILER TANK DESCOPE)\DWGS\8024-E4.dwg, 6/1/2020 1:53:28 PM, CORTEGA

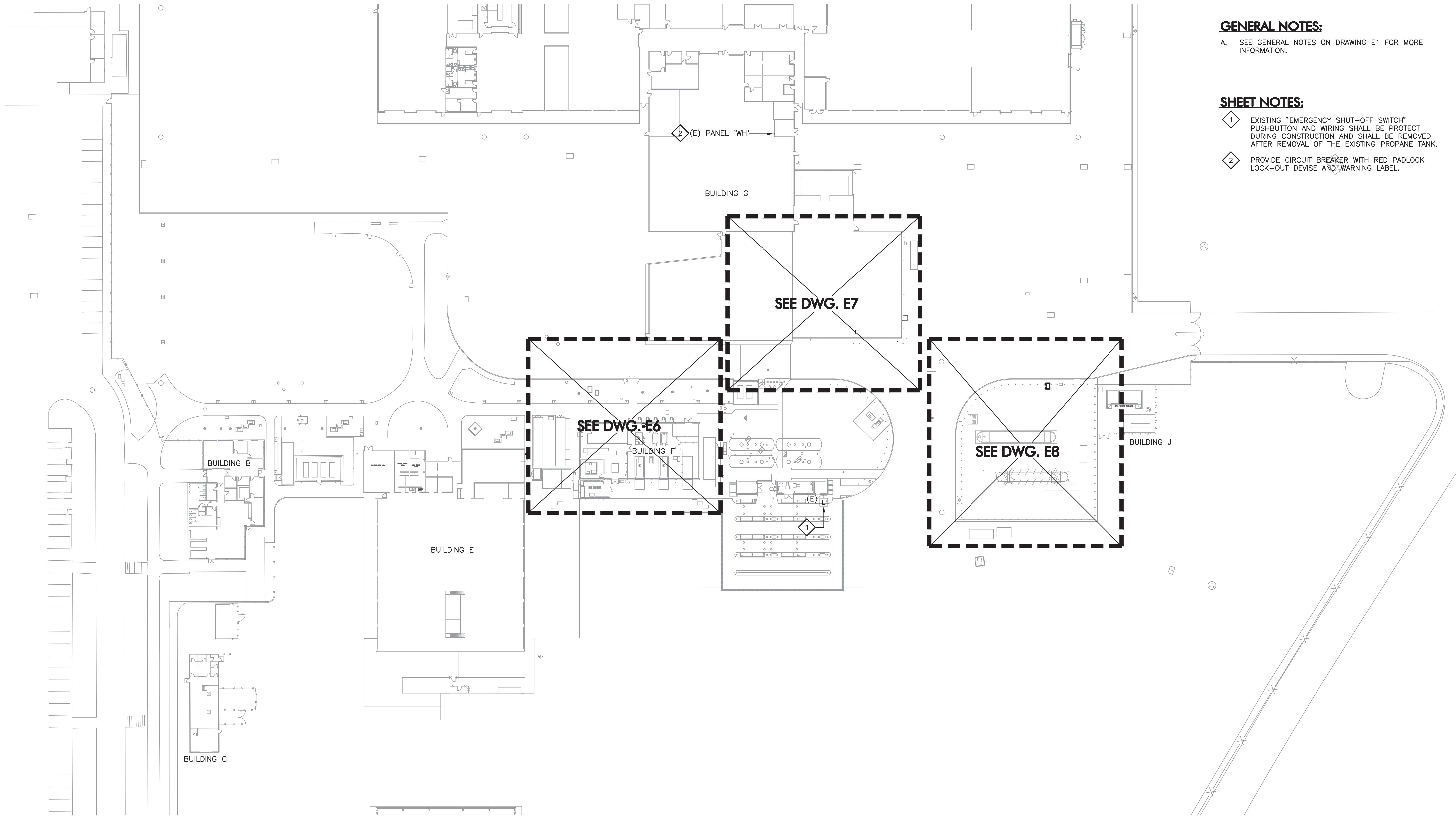

**GENERAL NOTES:**

A. SEE GENERAL NOTES ON DRAWING E1 FOR MORE INFORMATION.

**SHEET NOTES:**

- 1 EXISTING "EMERGENCY SHUT-OFF SWITCH" PUSHBUTTON AND WIRING SHALL BE PROTECT DURING CONSTRUCTION AND SHALL BE REMOVED AFTER REMOVAL OF THE EXISTING PROPANE TANK.
- 2 PROVIDE CIRCUIT BREAKER WITH RED PADLOCK LOCK-OUT DEVISE AND WARNING LABEL.

1 ELECTRICAL SITE PLAN - OVERALL  
1"=40'-0"

NO.	DATE	REVISIONS
1	01/30/20	ISSUED FOR BID



**ACKERMAN PRACTICON**  
CONSOLIDATED TECHNICAL SERVICES  
801 E. CHARLESTON ROAD PALO ALTO, CA 94303  
650 . 965 . 1000 FAX: 650 . 494 . 9312  
A-P PROJECT NUMBER: 18024

DESIGNED	E0	CHECKED	DK
DRAWN	CO	CADD FILE NAME	8024-E6.dwg



APPROVED	
CADD FILE DATE	SCALE
JULY 01, 2018	AS NOTED
PLOT DATE	BOARD APPROVAL DATE
-	-

<b>CERONE DIVISION BOILER AND PROPANE TANK REPLACEMENT</b>		
<b>ELECTRICAL SITE PLAN - OVERALL</b>		
SAP NO.	CONTRACT NO. C19123	FILE LOCATION

SHEET	41
OF 49	
DRAWING NO.	E4
REVISION	1

U:\18024.01 (VTA BOILER TANK DESCOPE)\DWGS\18024-E5-8.dwg, 6/2/2020 3:23:53 PM, Carlos

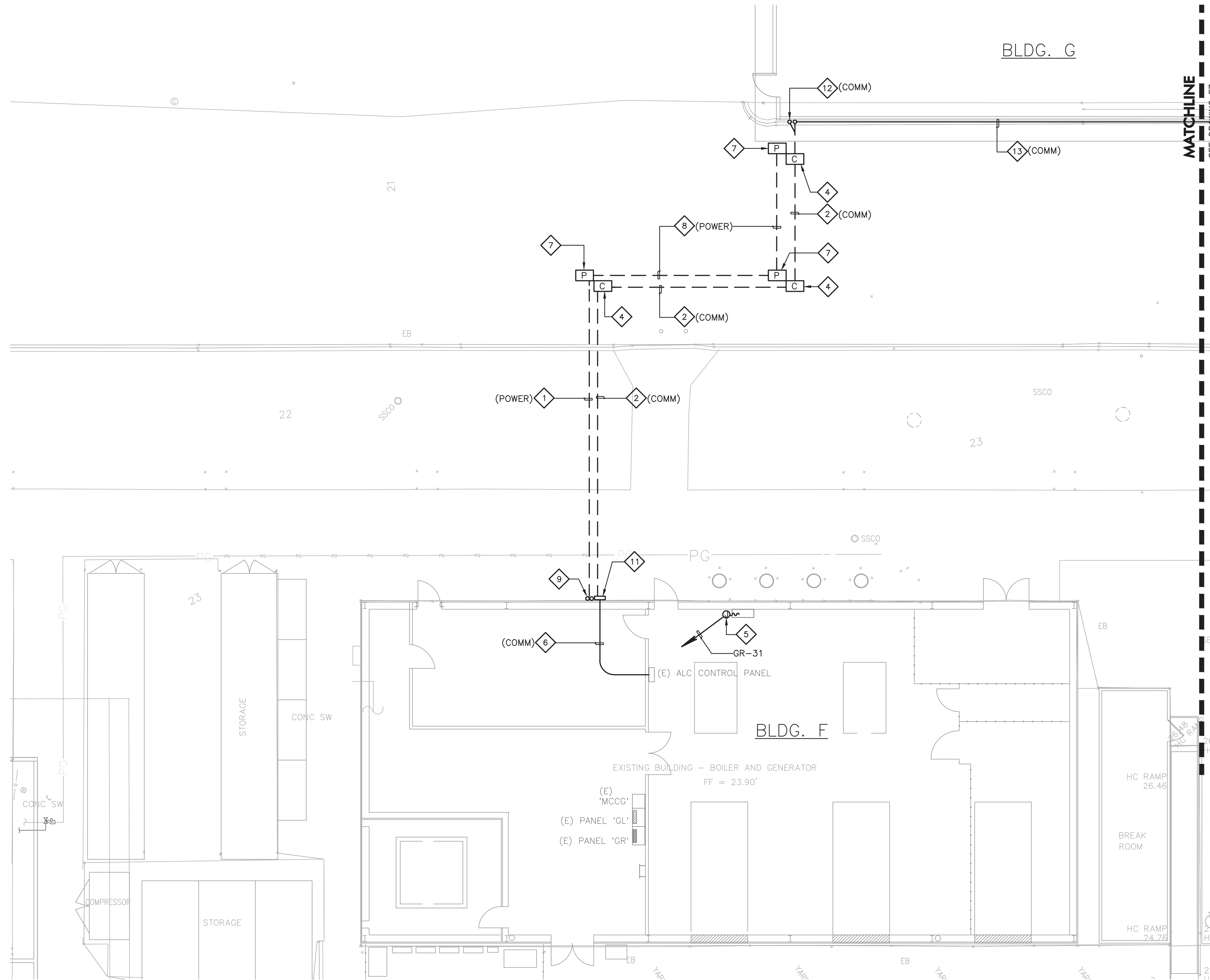

MATCHLINE  
SEE DRAWING E7  
FOR CONTINUATION

**GENERAL NOTES:**

A. SEE GENERAL NOTES ON DRAWINGS E1 AND E7 FOR MORE INFORMATION.

**SHEET NOTES:**

- 1 (2)2" - CONDUIT WITH PULL ROPE FOR SPARE. CONDUITS ROUTING AND DEPTH SHALL BE COORDINATED WITH ALL OTHER UTILITIES AND SITE CONDITION.
- 2 (1)2" - CONDUIT WITH PULL ROPE FOR FUTURE "ALC" CONNECTION TO BUILDING "F" ROUTER. (1)2" - CONDUIT WITH PULL ROPE SPARE.
- 3 NOT USED.
- 4 17"x30"x40" DEEP (NOMINAL) TRAFFIC RATED UTILITY BOX FOR CONTROL/MONITORING AND COMM CABLES WITH BOLT DOWN STEEL LID AND LABEL TO READ: COMM CHRISTY BOX OR APPROVED EQUAL. SEE SHEET E7 GENERAL NOTES FOR REQUIREMENTS.
- 5 20A, 120V CIRCUIT FOR WATER TREATMENT SYSTEM, CONNECT AND PER MANUFACTURER'S INSTALLATION INSTRUCTIONS. COORDINATE LOCATION PRIOR TO ROUGH-IN.
- 6 (1)2" - CONDUIT FOR COMM CABLES WITH PULL ROPE.
- 7 17"x30"x40" DEEP (NOMINAL) TRAFFIC RATED ELECTRICAL UTILITY BOX FOR POWER WIRING WITH BOLT DOWN STEEL LID AND LABEL TO READ: POWER CHRISTY BOX OR APPROVED EQUAL. SEE SHEET E7 GENERAL NOTES FOR REQUIREMENTS. EXACT LOCATION SHALL BE COORDINATED WITH ALL OTHER UTILITIES AND SITE CONDITION.
- 8 (2)2" - CONDUIT WITH PULL ROPE FOR SPARE. CONDUITS ROUTING AND DEPTH SHALL BE COORDINATED WITH ALL OTHER UTILITIES AND SITE CONDITION.
- 9 (2)2" - CONDUITS STUBBED-UP AND CAP AT 12" ABOVE FINISHED GRADE FOR FUTURE POWER.
- 10 NOT USED
- 11 18"x18"x6" DEEP PULLBOX WITH GASKETED HINGED LOCKABLE COVER MOUNTED AT +36" ABOVE FINISHED GRADE.
- 12 (1)1" - CONDUITS STUBBED-UP AND CAP AT 12" ABOVE FINISHED GRADE FOR FUTURE COMM. CABLES.
- 13 (1)1" - CONDUIT WITH PULL ROPE. RUN ALONG WALL AT EAVE OF ROOF AND EXTEND TO UTILITY BOX SHOWN ON SHEET E7.

**1 ELECTRICAL PLAN - AREA 2**  
1/8"=1'-0"

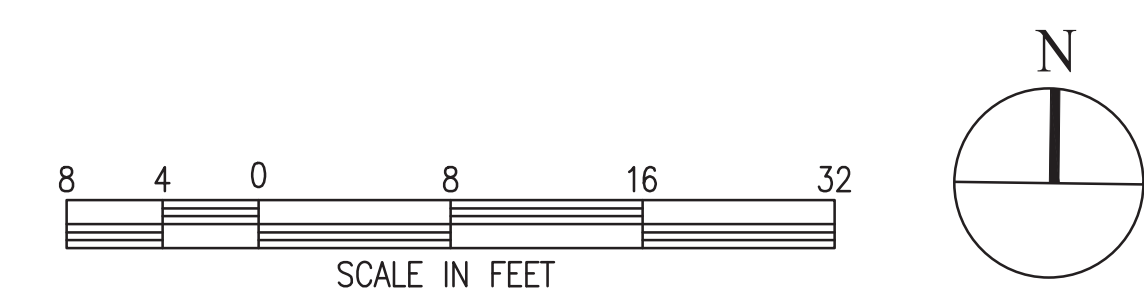

NO.	DATE	REVISIONS
1	01/30/20	ISSUED FOR BID



**ACKERMAN PRACTICON**  
CONSOLIDATED TECHNICAL SERVICES  
801 E. CHARLESTON ROAD PALO ALTO, CA 94303  
650 . 965 . 1000 FAX: 650 . 494 . 9312  
A-P PROJECT NUMBER: 18024

DESIGNED: EO CHECKED: DK  
DRAWN: CO CADD FILE NAME: 8024-E7-10.dwg



APPROVED	
CADD FILE DATE JULY 01, 2018	SCALE AS NOTED
PLOT DATE	BOARD APPROVAL DATE

**CERONE DIVISION  
BOILER AND PROPANE TANK  
REPLACEMENT  
ELECTRICAL  
PLAN AREA 2**

SAP NO. CONTRACT NO. C19123 FILE LOCATION

SHEET **43**  
OF 49  
DRAWING NO. **E6**  
REVISION **1**



U:\18024.01 (VTA BOILER TANK DESCOPE)\DWGS\18024-E5-8.dwg, 6/2/2020 3:25:07 PM, Carlos

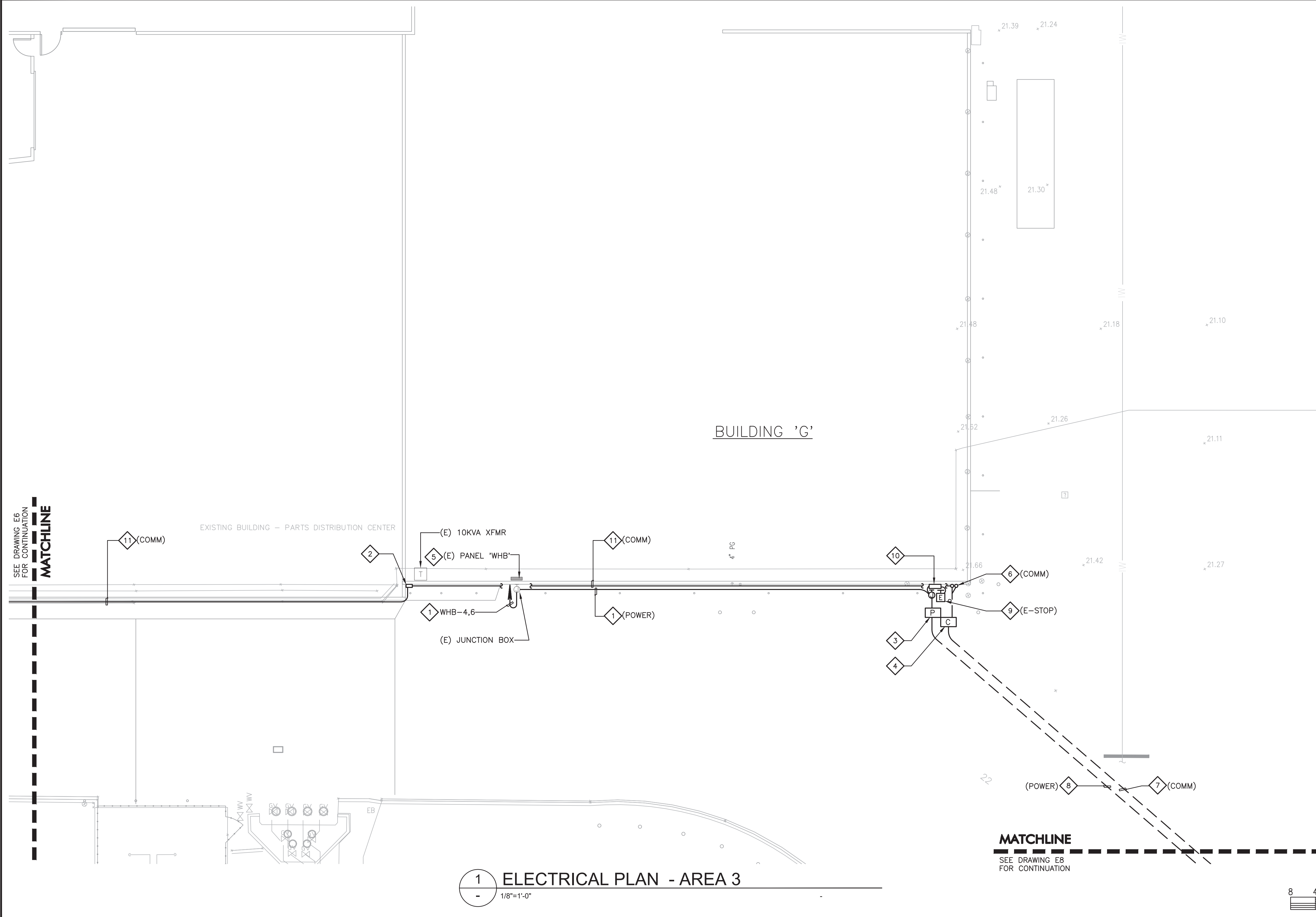

**GENERAL NOTES:**  
A. SEE GENERAL NOTES ON DRAWINGS E1 AND E7 FOR MORE INFORMATION.

- SHEET NOTES:**
- 1 (1)1"- CONDUIT, 2#10, 1#10(G) FOR "EMERGENCY SHUT-OFF SWITCH" AND 2#10, 1#10(G) FOR VAPORIZER. ROUTE CONDUIT ALONG EXTERIOR WALL AT +/-12" ABOVE GRADE.
  - 2 6"x6"x4"D PULL BOX AT EAVE OF ROOF. COORDINATE EXACT LOCATION IN FIELD.
  - 3 17"x30"x40" DEEP (NOMINAL) TRAFFIC RATED ELECTRICAL UTILITY BOX FOR POWER WIRING WITH BOLT DOWN STEEL LID AND LABEL TO READ: POWER CHRISTY BOX OR APPROVED EQUAL. SEE SHEET E7 GENERAL NOTES FOR REQUIREMENTS. EXACT LOCATION SHALL BE COORDINATED WITH ALL OTHER UTILITIES AND SITE CONDITION.
  - 4 17"x30"x40" DEEP (NOMINAL) TRAFFIC RATED UTILITY BOX FOR CONTROL/MONITORING AND COMM CABLES WITH BOLT DOWN STEEL LID AND LABEL TO READ: COMM CHRISTY BOX OR APPROVED EQUAL. SEE SHEET E7 GENERAL NOTES FOR REQUIREMENTS.
  - 5 SEE SINGLE LINE DIAGRM DWG. E2 AND PANEL SCHEDULE DWG. E9 FOR PANELS FOR MORE INFORMATION.
  - 6 (1)1"- CONDUITS STUBBED-UP AND CAP AT 12" ABOVE FINISHED GRADE FOR FUTURE COMM. CABLES.
  - 7 (2)1"- CONDUIT WITH PULL ROPE FOR (F) "ALC" COMM CABLES.
  - 8 (1)1"- CONDUIT, 2#10, 1#10(G) FROM "EMERGENCY SHUT-OFF SWITCH" TO P.G. SHUT-OFF VALVE(SV).
  - 9 (1)1"- CONDUIT, 2#10, 1#10(G) FROM PANEL "WHB" TO VAPORIZER. CONDUITS ROUTING AND DEPTH SHALL BE COORDINATED WITH ALL OTHER UTILITIES AND SITE CONDITION.
  - 9 NEMA 3R, HEAVY DUTY EMERGENCY SHUT-OFF SWITCH MOUNT AT +50". SEE DETAILS #2 AND #5 ON DWG. E10 FOR MORE INFORMATION.
  - 10 NEMA 3R HOFFMAN BOX FOR CONTROL TRANSFORMER, SEE DETAILS #2 AND #5 ON DWG. E10 FOR MORE INFORMATION.
  - 11 (1)1"- CONDUIT WITH PULL ROPE. RUN ALONG WALL AT EAVE OF ROOF BACK TO UTILITY BOX SHOWN ON SHEET E6.

**1 ELECTRICAL PLAN - AREA 3**  
1/8"=1'-0"

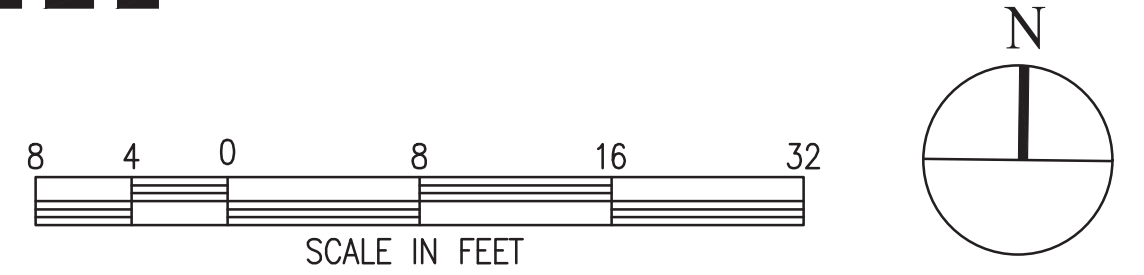

NO.	DATE	REVISIONS
1	01/30/20	ISSUED FOR BID



**ACKERMAN PRACTICON**  
CONSOLIDATED TECHNICAL SERVICES  
801 E. CHARLESTON ROAD PALO ALTO, CA 94303  
650 . 965 . 1000 FAX: 650 . 494 . 9312  
A-P PROJECT NUMBER: 18024

DESIGNED: EO  
CHECKED: DK  
DRAWN: CO  
CADD FILE NAME: 8024-E7-10.dwg



APPROVED

CADD FILE DATE JULY 01, 2018	SCALE 1/8"=1'-0"
PLOT DATE	BOARD APPROVAL DATE

**CERONE DIVISION  
BOILER AND PROPANE TANK  
REPLACEMENT**

**ELECTRICAL  
PLAN AREA 3**

SHEET 44 OF 49 DRAWING NO. E7 REVISION 1

SAP NO. CONTRACT NO. C19123 FILE LOCATION



U:\18024.01 (VTA BOILER TANK DESCOPE)\DWGS\18024-E5-8.dwg, 6/2/2020 3:26:12 PM, Carlos

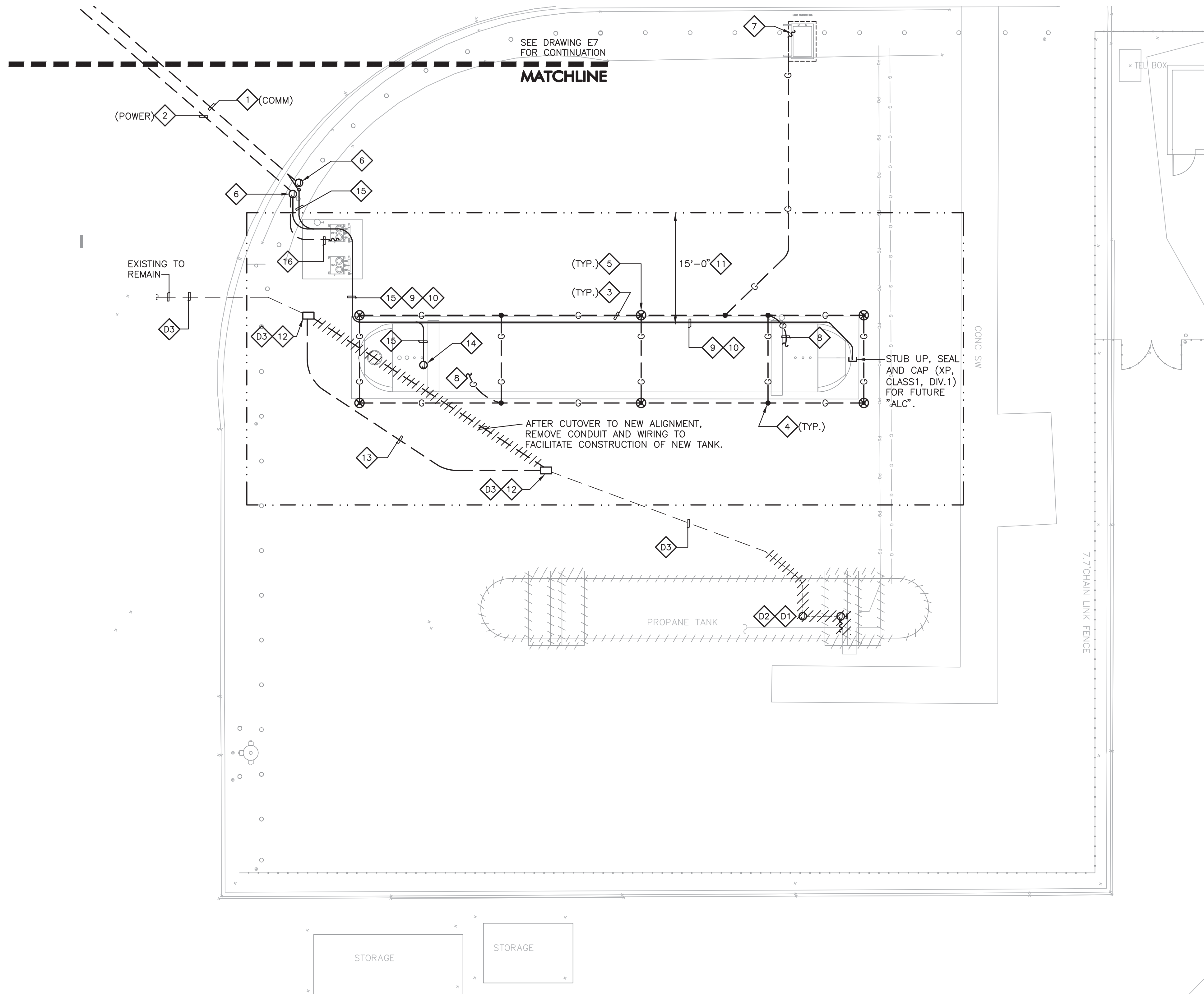

**SHEET NOTES:**

- 1 (2)1"- CONDUIT WITH PULL ROPE FOR (F) ALC COMM CABLES.
- 2 (1)1"- CONDUIT, 2#10, 1#10(G) FROM "EMERGENCY SHUT-OFF SWITCH" TO P.G. SHUT-OFF VALVE (SV).
- (1)1"- CONDUIT, 2#10, 1#10(G) (WHB-6) FOR VAPORIZER.
- 3 #4/0 BARE COPPER GROUND WIRE DIRECT BURIED AT 24" BELOW GRADE OUTSIDE AROUND THE PERIMETER OF FOUNDATION. CROSS RUNS SHALL BE EMBEDDED IN FOOTING AND BONDED TO REBAR USING EXOTHERMIC WELD OR COMPRESSION FITTING.
- 4 EXOTHERMIC WELD AT GROUNDING SYSTEM/WIRE.
- 5 GROUND ROD IN INSPECTION WELL, SEE DETAIL #3/E10 FOR MORE INFORMATION.
- 6 4"x4" EXPLOSION PROOF (CLASS I, DIV.2), DUST PROOF, RAIN/TIGHT, WET LOCATIONS AND WATERTIGHT BOX WITH (4) 0.75" HUBS AND CONDUITS MOUNTED AT PROPANE PIPE RACK (ABOVE/NEAR TRANSITION POINT FROM U/G TO A/G) WHERE POSSIBLE, OTHERWISE PROVIDE WITH MOUNTING SUPPORTS AS REQUIRED. ONE BOX AND CONDUITS FOR FUTURE POWER WIRING AND THE OTHER BOX FOR FUTURE ALC COMMUNICATION CABLES. PROVIDE CAP FOR FUTURE (UNUSED) HUBS. COORDINATE WITH PROPANE PIPING CONTRACTOR FOR THE EXACT LOCATION PRIOR TO ROUGH-IN. CROUSE-HINDS "GUP," "GUB" SERIES OR APPROVED EQUAL.
- 7 GROUND STUD AT "LP" FILL STATION.
- 8 #2/0 BARE COPPER GROUND WIRE TO BOND PROPANE TANK STEEL, N2 STATION.
- 9 RUN CONDUITS ON SAME PIPE RACK AS THE PROPANE PIPING WHERE POSSIBLE OTHERWISE PROVIDE NEW SUPPORT FOR NEW CONDUITS AS REQUIRED.
- 10 (1)1" CONDUIT WITH PULL ROPE (SPARE) FOR FUTURE ALC COMMUNICATION. RUN CONDUITS ON SAME PIPE RACK AS THE PROPANE PIPING WHERE POSSIBLE, OTHERWISE PROVIDE CONDUIT MOUNTING SUPPORT AS REQUIRED.
- 11 ALL ABOVE GROUND ELECTRICAL WORK WITHIN THE BOUNDARY (IN ALL DIRECTIONS) SHALL COMPLY WITH EXPLOSION PROOF LOCATIONS (CLASS 1, DIVISION I AREA WITHIN 5 FT. AND CLASS 1, DIVISION II AREA WITHIN 15 FT.) REQUIREMENTS.
- 12 FIELD VERIFY EXISTING RACEWAY, INTERCEPT, PROVIDE AND INSTALL ONE 18" x 18" x 6" DEEP PULL BOX WITH BOLT DOWN COVER FOR SIGNAL AND CONTROL CABLES AND REROUTE CONDUIT AND WIRING TO ALLOW CONSTRUCTION OF THE NEW TANK.
- 13 NEW CONDUITS AND WIRING SHALL MATCH EXISTING. COORDINATE WITH CONSTRUCTION PRIOR TO DISCONNECTING EXISTING WIRING.
- 14 EXPLOSIONPROOF (CLASS 1, DIVISION I) BOX, CONDUIT AND WIRING MOUNTED AT CONCRETE SADDLE FOR P.G. EMERGENCY SHUT-OFF VALVE (SV) SHOWN ON PLUMBING DRAWINGS. SEE SHEET E10 WIRING DIAGRAM FOR MORE INFORMATION.
- 15 (1)1" CONDUIT WITH 2#10, 1#10(G) FOR P.G.EMERGENCY SHUT-OFF VALVE (SV).
- 16 (1)1" CONDUIT, 2#10, 1#10(G) FOR VAPORIZER, CONNECT AS PER MANUFACTURER'S INSTALLATION INSTRUCTIONS AND COORDINATE PRIOR TO ROUGH-IN.

**GENERAL NOTES:**

- A. SEE GENERAL NOTES ON DRAWINGS E1 AND E7 FOR MORE INFORMATION.
- B. ALL WIRING AND WIRING DEVICES WITHIN 15 FEET OF PROPANE TANK SHALL BE CLASS 1, DIVISION II FROM VALVE AND CLASS 1, DIVISION I WITHIN 5 FEET FROM TANK. ALL CONDUITS SHALL BE RIGID STEEL WITH SEAL FITTINGS AT EACH END OF CONDUIT RUNS.

**DEMOLITION NOTES:**

- D1 DISCONNECT GROUNDING, CONTROL AND POWER WIRING AFTER (E) PROPANE TANK IS REMOVED. DISCONNECT POWER AND CONTROL WIRING FROM THE SOURCE PANEL AND LABEL THEM AS "SPARE".
- D2 DISCONNECT AND REMOVE ALL UNUSED CONDUITS, BOXES AND WIRING AFTER INSTALLATION OF THE NEW PROPANE TANK AND ASSOCIATED SYSTEMS ARE COMPLETED.
- D3 REMOVE UNUSED CONDUCTORS AFTER EXISTING TANK IS DEMOLISHED.

1 ELECTRICAL PLAN - AREA 4  
1/8"=1'-0"

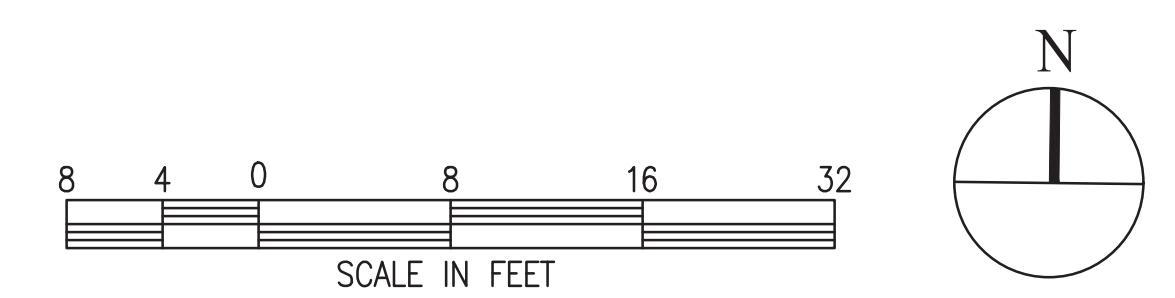

NO.	DATE	REVISIONS
1	01/30/20	ISSUED FOR BID



**ACKERMAN PRACTICON**  
CONSOLIDATED TECHNICAL SERVICES  
801 E. CHARLESTON ROAD PALO ALTO, CA 94303  
650 . 965 . 1000 FAX: 650 . 494 . 9312  
A-P PROJECT NUMBER: 18024

DESIGNED: EO  
CHECKED: DK  
DRAWN: CO  
CADD FILE NAME: 8024-E7-10.dwg



APPROVED	
CADD FILE DATE JULY 01, 2018	SCALE AS NOTED
PLOT DATE	BOARD APPROVAL DATE

CERONE DIVISION BOILER AND PROPANE TANK REPLACEMENT		SHEET OF 49 DRAWING NO. E8
ELECTRICAL PLAN AREA 4		REVISION 1
SAP NO.	CONTRACT NO. C19123	FILE LOCATION

U:\18024.01 (VTA BOILER TANK DESCOPE)\DWGS\8024-E9.dwg, 6/2/2020 3:28:08 PM, Carlos

(E) PANEL 'GR' LOCATION: BUILDING 'F' VOLTAGE: 120/208V, 3φ, 4W + G

DESCRIPTION	KVA LOAD			CB	C C T	C C T	CB	KVA LOAD			DESCRIPTION
	φ A	φ B	φ C					φ A	φ B	φ C	
(E)EB 3	-	-	-	20A/1	1	1	20A/1	-	-	-	(E)REC-GYM
(E)EB 2	-	-	-		3	4		-	-	-	(E)REC-GYM
(E)EB 1	-	-	-		5	6		-	-	-	(E)REC-GYM
(E)LOAD	-	-	-		7	8		-	-	-	(E)REC
(E)BOILER 2	-	-	-	A	9	10		-	-	-	(E)REC
↓				2P	11	12		-	-	-	(E)REC
(E)BOILER 1	-	-	-	20A/1	13	14	20A	-	-	-	SPARE
(E)BOILER 1	-	-	-		15	16		-	-	-	↓
SPARE	-	-	-		17	18	3P	-	-	-	↓
(E)BOILER TCP	-	-	-		19	20	20A/1	-	-	-	(E)A/C-OFFICE
SPARE	-	-	-		21	22	30A	-	-	-	↓
(E)REC-ELEC RM	-	-	-		23	24	2P	-	-	-	↓
(E)LOAD	-	-	-		25	26	20A/1	-	-	-	(E)PHONE BOARD
(E)HEAT PUMP	-	-	-	30A	27	28	15A/1	-	-	-	(E)LTG-STORAGE
↓				2P	29	30	20A/1	-	-	-	(E)GYM
1 WTR TREATMENT SYSTEM	0.2	-	-	20A/1	31	32	20A/1	-	-	-	(E)GYM
SPACE	-	-	-		33	34	25A/1	-	-	-	SPARE
SPACE	-	-	-		35	36		-	-	-	SPACE
SPACE	-	-	-		37	38		-	-	-	SPACE
SPACE	-	-	-		39	40		-	-	-	SPACE
SPACE	-	-	-		41	42		-	-	-	SPACE

TRIM STYLE:  FLUSH  SURFACE  
 BUS RATING:  100 A  200 A  225 A  400 A  
 MAIN CB 100A  
 MAIN LUGS ONLY  DOUBLE LUGS

CONNECTED LOAD  
 φ A 22.3 KVA  
 φ B 22.3 KVA  
 φ C 22.3 KVA  
 TOTAL 66.9 KVA

**GENERAL NOTES:**  
 A. SEE GENERAL NOTES ON DRAWINGS E1 AND E7 FOR BREAKER ISC RATING AND MORE INFORMATION.

**SHEET NOTES:**

- 1 PROVIDE (N) CIRCUIT BREAKER FOR NEW WORK AS SHOWN ON PLANS AND PANEL SCHEDULE. (N) CIRCUIT BREAKER TO MATCH (E).
- 2 UTILIZE AND RE-USE (E) CIRCUIT BREAKER FOR NEW WORK/WIRING.
- 3 PROVIDE CIRCUIT BREAKER WITH RED PADLOCK LUCK-OUT DEVICE AND WARNING LABEL AT BREAKER FOR P.G. EMERGENCY SHUT-OFF CIRCUIT.

(E) PANEL 'WHB' LOCATION: BUILDING 'G' VOLTAGE: 120/208V, 1φ, 3W + G

DESCRIPTION	VA LOAD		CB	C C T	C C T	CB	VA LOAD		DESCRIPTION
	φ A	φ B					φ A	φ B	
(E) MAIN	1.0	-	50A	1	1	20A/1	1.0	-	(E) LOAD
↓			2P	3	4		0.2	-	VAPORIZERS
(E) LOAD	1.0	-	20A/1	5	6	↓	0.2	-	E-STOP SWITCH
				7	8				
				9	10				
				11	12				
				13	14				
				15	16				
				17	18				
				19	20				
				21	22				
				23	24				
				25	26				
				27	28				
				29	30				
				31	32				
				33	34				
				35	36				
				37	38				
				39	40				
				41	42				

TRIM STYLE:  FLUSH  SURFACE  
 BUS RATING:  100 A  200 A  225 A  400 A  
 MAIN CB 100A  
 MAIN LUGS ONLY  DOUBLE LUGS

CONNECTED VA  
 0A  
 0B  
 TOTAL

No.	DATE	REVISIONS
1	01/30/20	ISSUED FOR BID

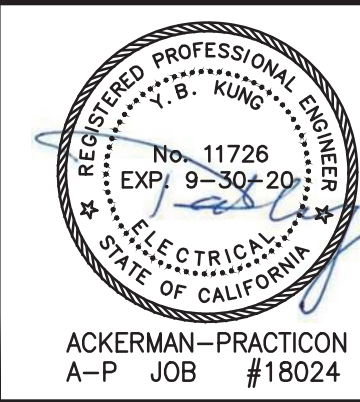

**ACKERMAN PRACTICON**  
 CONSOLIDATED TECHNICAL SERVICES  
 801 E. CHARLESTON ROAD PALO ALTO, CA 94303  
 650 . 965 . 1000 FAX: 650 . 494 . 9312  
 A-P PROJECT NUMBER: 18024

DESIGNED: EO CHECKED: DK  
 DRAWN: CO CADD FILE NAME: 8024-E12.dwg



APPROVED

CADD FILE DATE: JULY 01, 2018 SCALE: AS NOTED  
 PLOT DATE: - BOARD APPROVAL DATE: -

CERONE DIVISION  
 BOILER AND PROPANE TANK REPLACEMENT  
 ELECTRICAL PANEL SCHEDULES

SAP NO. CONTRACT NO. C19123 FILE LOCATION

SHEET 47 OF 49 DRAWING NO. E9 REVISION 1



U:\18024.01 (VTA BOILER TANK DESCOPE)\DWGS\8024-E10.dwg, 6/2/2020 3:29:37 PM, Carlos

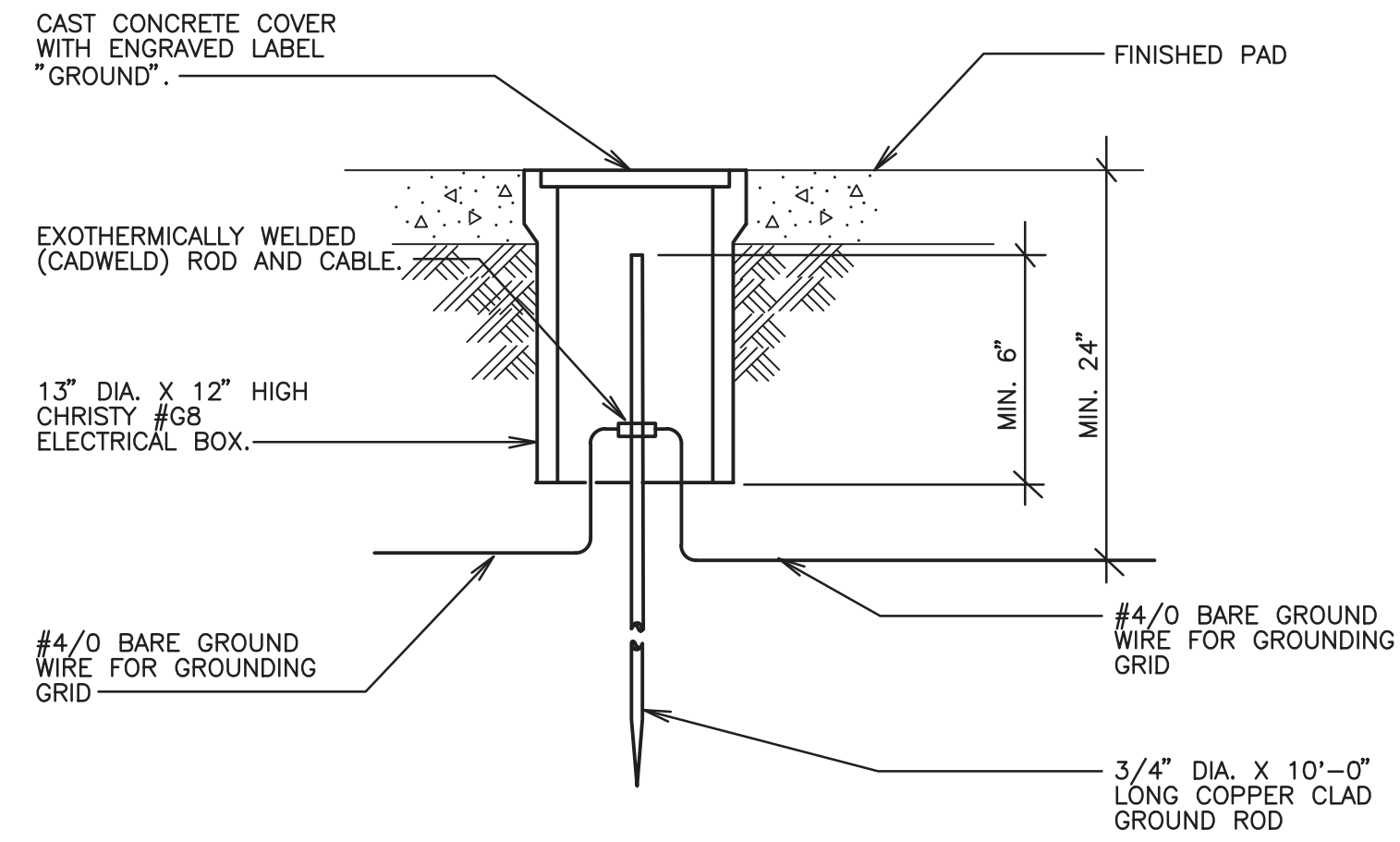

**3** GROUND ROD WITH INSPECTION WELL  
- NOT TO SCALE

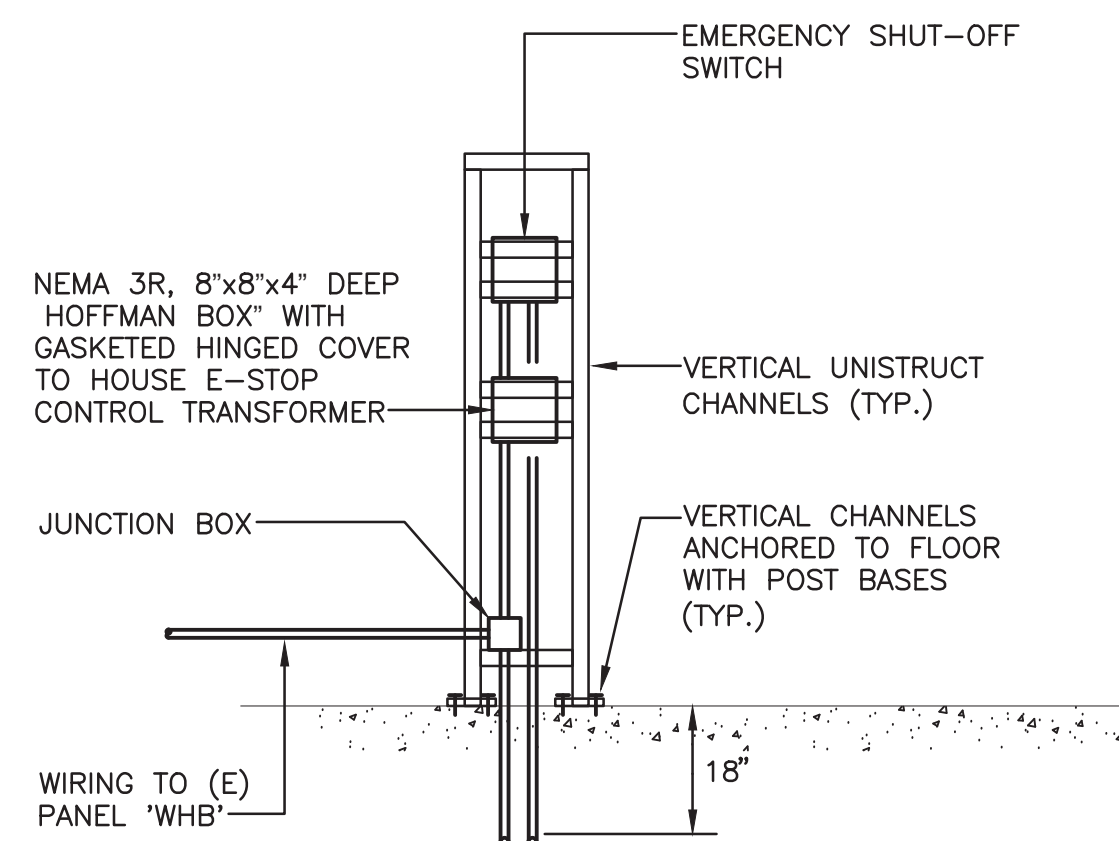

DETAIL NOTE:  
SEE STRUCTURAL DRAWINGS FOR PANEL MOUNTING AND SUPPORT INFORMATION.

**5** PANEL MOUNTING DETAIL  
- NOT TO SCALE

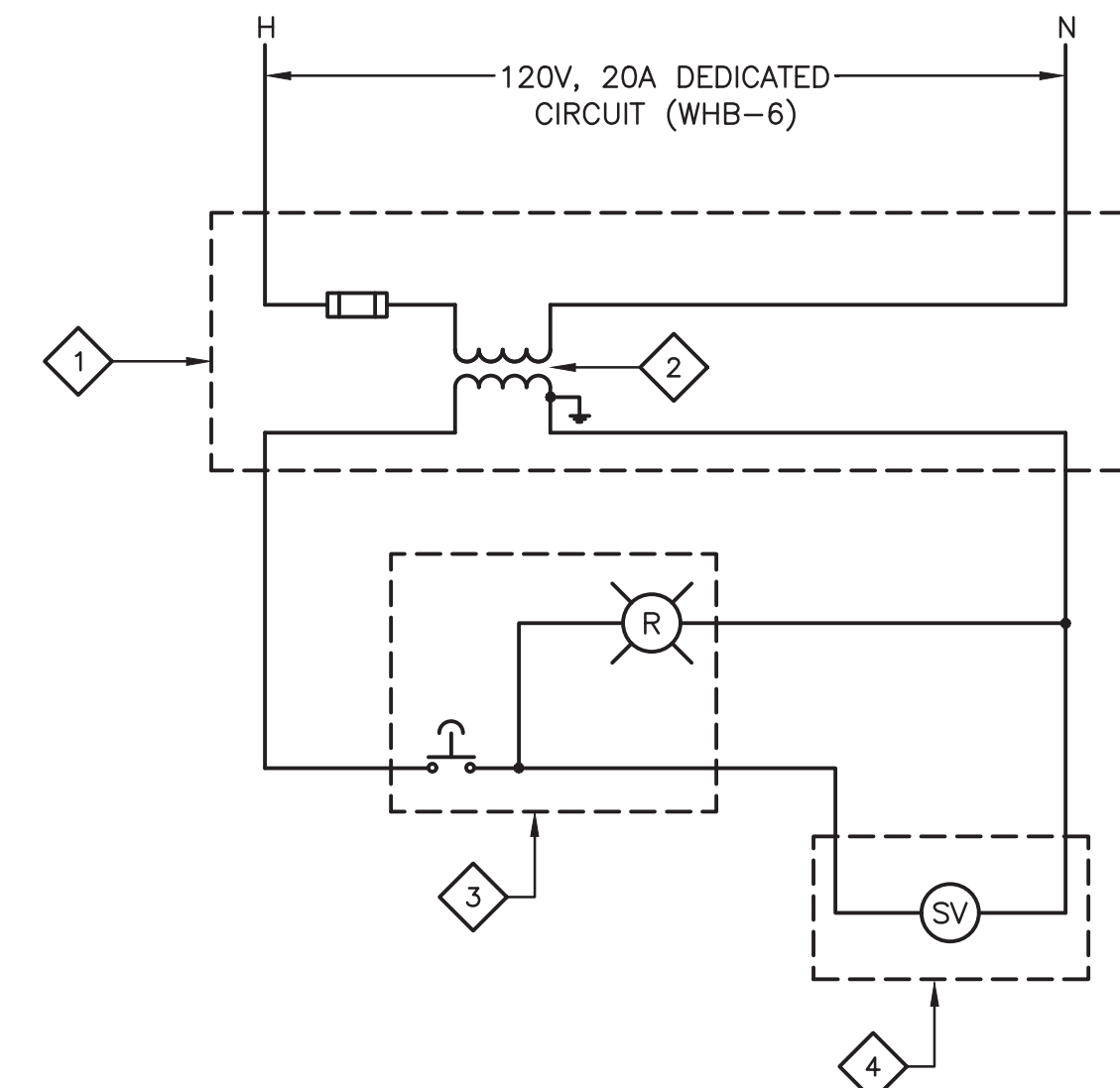

DETAIL NOTES:

- 1 NEMA 3R, 8"x8"x4" DEEP HOFFMAN BOX" WITH GASKETED HINGED COVER TO HOUSE CONTROL TRANSFORMER.
- 2 500 VA, 120/24V CONTROL TRANSFORMER.
- 3 EMERGENCY SHUT-OFF PUSH BUTTON SWITCH, 24V, MUSHROOM-HEAD AND RED COLOR. ON/OFF OPERATION, IN CASE OF EMERGENCY PUSH TO LOCK TO AND ACTIVATE THE SHUT-OFF VALVE AND RED ALARM LIGHT AND TURN TO RESET TO NORMAL POSITION, PROVIDED WITH BACK BOX, PROTECTION GUARD AND HINGED COVER AND LABEL BOARD TO READ: EMERGENCY PROPANE TANK SHUT DOWN".
- 4 PROPANE TANK SHUT-OFF SOLENOID VALVE (24V) AS SHOWN ON PLUMBING DRAWINGS.

**2** PROPANE EMERGENCY SHUT-OFF SWITCH WIRING DIAGRAM  
- NOT TO SCALE

No.	DATE	REVISIONS
1	01/30/20	ISSUED FOR BID



<b>ACKERMAN PRACTICON</b> CONSOLIDATED TECHNICAL SERVICES 801 E. CHARLESTON ROAD PALO ALTO, CA 94303 650 . 965 . 1000 FAX: 650 . 494 . 9312 A-P PROJECT NUMBER: 18024			
DESIGNED	EO	CHECKED	DK
DRAWN	CO	CADD FILE NAME	8024-E13.dwg



APPROVED	
CADD FILE DATE	SCALE
JULY 01, 2018	AS NOTED
PLOT DATE	BOARD APPROVAL DATE
-	-

CERONE DIVISION BOILER AND PROPANE TANK REPLACEMENT ELECTRICAL DETAILS			SHEET OF 49 DRAWING NO. <b>E10</b> REVISION 1
SAP NO.	CONTRACT NO. C19123	FILE LOCATION	

## **APPENDICES**

### **Table of Contents**

<b>Appendix A</b>	Insurance Requirements
<b>Appendix B</b>	Contract Data Requirements
<b>Appendix C</b>	Business Diversity Policy and Requirements
<b>Appendix D</b>	Reserved
<b>Appendix E</b>	Reserved
<b>Appendix F</b>	Reserved
<b>Appendix G</b>	Environmental Coordination and Cooperation
<b>Appendix H</b>	Reserved
<b>Appendix I</b>	Prequalification Requirements
<b>Appendix J</b>	Reserved
<b>Appendix K</b>	Reserved
<b>Appendix L</b>	Reserved
<b>Appendix M</b>	Quality Assurance and Quality Control Requirements
<b>Appendix N</b>	Regulatory Permit Applications
<b>Appendix O</b>	Hazardous Material Survey Report
<b>Appendix P</b>	VTA Contract C19010 Reference Drawings
<b>Appendix Q</b>	Guidelines for Preparation of IIPP & SSSP
<b>Appendix R</b>	Existing Utility Information
<b>Appendix S</b>	Procedure on Reflective Safety Vests
<b>Appendix T</b>	Bldg G HHW & Propane Reference Drawing

*[This Page Intentionally Left Blank]*

## **APPENDIX A**

### **INSURANCE REQUIREMENTS**

Without limiting Contractor's obligation to indemnify and hold harmless VTA, Contractor must procure and maintain for the duration of the Contract insurance against claims for injuries to persons or damages to property which may arise from or in connection with the performance of the Work hereunder by Contractor, its agents, representatives, or employees, or subcontractors. The cost of such insurance must be included in Contract price. In the event of any material change in the Contract Scope of Services, VTA reserves the right to change the insurance requirements set forth herein. Contractor must furnish complete copies of all insurance policies, within three (3) business days of any request for such by VTA.

#### **A. Liability and Workers' Compensation Insurance**

##### **1. Minimum Scope of Coverage**

Coverage must be at least as broad as:

- a. General Liability coverage; Insurance Services Office "occurrence" form CG 0001. General Liability insurance written on a "claims made" basis is not acceptable. Completed Operations coverage must be continuously maintained for at least two (2) years after Final Acceptance of the Work.
- b. Business Auto Coverage, Insurance Services Office form number CA 0001, covering Automobile Liability, code 1 "any auto." Auto Liability insurance written on a "claims made" basis is not acceptable.
- c. Workers' Compensation insurance, as required by the Labor Code of the State of California, and Employer's Liability insurance.
- d. Contractor's Pollution Liability: covering liability arising out of the treatment, handling, storage, transportation, or accidental release of any hazardous material.

##### **2. Minimum Limits of Insurance**

- a. Contractor must maintain limits no less than:
  1. General Liability (including umbrella/excess liability): \$10,000,000 limit per occurrence for bodily injury, personal injury, and property damage. If General Liability Insurance or other form with a general aggregate limit is used, either the general aggregate limit must apply separately to this project/location or the general aggregate limit must be twice the required occurrence limit. This requirement may be satisfied by a combination of General Liability with Excess or Umbrella, but in no event may the General Liability primary policy limit per occurrence be less than \$2,000,000, unless Umbrella/Excess policies feature inception and expiration dates concurrent with the underlying General Liability policy, "Follow Form" coverage, and a "Drop Down" provision.
  2. Automobile Liability (including umbrella/excess liability): \$7,500,000 limit per accident for bodily injury and property damage. This requirement may be satisfied by a combination of Auto with Excess or Umbrella, but in no event may the Automobile Liability primary policy limit per occurrence be less than \$2,000,000, unless Umbrella/Excess policies

feature inception and expiration dates concurrent with the underlying auto liability policy, "Follow Form" coverage, and a "Drop Down" provision.

3. Workers' Compensation and Employer's Liability: Statutory Workers' Compensation limits and Employer's Liability limits of \$1,000,000 per accident.
  4. Contractor's Pollution Liability: \$3,000,000 per occurrence. This requirement may be satisfied by a combination of Pollution Liability with Excess or Umbrella, but in no event may the Pollution Liability primary policy limit per occurrence be less than \$2,000,000, unless Umbrella/Excess policies feature inception and expiration dates concurrent with the underlying auto liability policy, "Follow Form" coverage, and a "Drop Down" provision.
- b. Notwithstanding any language in this Contract to the contrary, if the Contractor carries insurance limits exceeding the minima stated in Section 2(a)(1)-(4) immediately above, such greater limits will apply to this Contract.

### **3. Self-Insured Retention**

The certificate of insurance must disclose the actual amount of any deductible or self-insured retention, or lack thereof, for all coverages required herein. Any self-insured retention or deductible in excess of \$50,000 (\$100,000 if Contractor is a publicly-traded company) must be declared to and approved by VTA. If Contractor is a governmental authority such as a state, municipality or special district, self-insurance is permitted. To apply for approval for a level of retention or deductible in excess of \$50,000, Contractor must provide a current financial report including balance sheets and income statements for the past three years, so that VTA can assess Contractor's ability to pay claims falling within the self-insured retention or deductible. Upon review of the financial report, if deemed necessary by VTA in its sole discretion, VTA may elect one of the following options: to accept the existing self-insured retention or deductible; require the insurer to reduce or eliminate the self-insured retention or deductible as respects VTA, its directors, officers, officials, employees and volunteers; or to require Contractor to procure a bond guaranteeing payment of losses and related investigations, claim administration and defense expenses. Applicable costs resulting therefrom will be borne solely by Contractor. Contractor may request execution of a nondisclosure agreement prior to submission of financial reports.

### **B. Builder's Risk Insurance**

To the extent allowed by law, Contractor is responsible for all loss or damage, howsoever caused, to the Work and materials until final acceptance by VTA.

Contractor must procure and maintain at its own expense Builder's Risk insurance (including but not limited to Builder's Risk, Course of Construction, Installation Floater or similar first-party property insurance covering the interest of Contractor and VTA) as follows:

1. Coverage must be provided on an "all-risk" basis. Coverage does not need to include the perils of Earthquake and/or Flood.
2. Coverage must apply to all Work and materials under this Contract, whether in process or manufacture or finished, including off-site storage, "in transit" coverage to the final agreed



upon destination of delivery, and including loading and unloading operations; and such coverage must be in force until the Work and materials are accepted by VTA.

3. Coverage must be in an amount no less than the full replacement value of the finished work and materials with no periodic reporting requirements.
4. The deductible may not exceed \$50,000 per occurrence and must be borne by Contractor.
5. Loss, if any, must be adjustable with and payable to VTA as trustee for all entities having an insurable interest.

**C. Claims Made Provisions (not applicable to General Liability or Auto Liability)**

Claims-made coverage is never acceptable for General Liability or Auto Liability. Claims-made may be considered for Professional, Environmental/Pollution, or Cyber Liability. If coverage is written on a claims-made basis, the Certificate of Insurance must clearly state so. In addition to all other coverage requirements, such policy must provide that:

1. The policy retroactive date must be no later than the date of this Contract.
2. If any policy is not renewed or the retroactive date of such policy is to be changed, Contractor must obtain or cause to be obtained the broadest extended reporting period coverage available in the commercial insurance market. This extended reporting provision must cover at least two (2) years.
3. No prior acts exclusion may be added to the policy during the contract period.
4. The policy allows for reporting of circumstances or incidents that might give rise to future claims.

**D. Other Provisions**

The policies must contain, or be endorsed to contain, the following provisions:

**1. General Liability, Automobile Liability and Environmental Impairment Liability**

- a. VTA, its directors, officers, officials, employees and volunteers are to be named as additional insureds as respects: liability arising out of activities performed by or on behalf of Contractor, including VTA's general supervision of Contractor; products and completed operations of Contractor and its subcontractors; premises owned, occupied or used by Contractor; or automobiles owned, leased, hired or borrowed by Contractor. The coverage must contain no special limitations on the scope of protection afforded to VTA, its directors, officers, officials, employees, or volunteers. Additional Insured endorsements must provide coverage at least as broad as afforded by the combination of ISO CG 20 10 10 01 and CG 20 37 10 01.
- b. Any failure to comply with reporting provisions of the policies may not affect coverage provided to VTA, its directors, officers, officials, employees, or volunteers.
- c. Contractor's insurance must apply separately to each insured against whom claim is made or suit is brought, except with respect to the limits of the insurer's liability.
- d. The General Liability General Aggregate limit must apply per project, not per policy.

- e. General Liability policy must be endorsed to remove the exclusion for railroad liabilities, with coverage at least as broad as afforded by ISO CG 24 17.

**2. All Coverages**

- a. The insurer must agree to waive all rights of subrogation against VTA, its directors, officers, officials, employees, and volunteers for losses arising from work performed by Contractor and its subcontractors for VTA.
- b. Contractor's insurance coverage must be primary insurance as respects VTA, its directors, officers, officials, employees, and volunteers. Self-insurance or insurance that may be maintained by VTA, its directors, officers, officials, employees, or volunteers may apply only as excess to the Contractor's insurance. Contractor's insurance must not seek contribution from VTA's insurance program.

**3. Other Insurance Provisions**

- a. The Certificate must disclose the actual amount of the Deductible or Self-Insured Retention.
- b. If any coverage forms or endorsements required by this Contract are updated by their publishers, whether they be the insurance carrier(s), the Insurance Services Office, or the American Association of Insurance Services, during the duration of this Contract, VTA reserves the rights to require the Contractor to procure said coverage forms or endorsements using the updated versions upon the next renewal cycle.

**E. Acceptability of Insurers**

Insurance and bonds must be placed with insurers with an A.M. Best's rating of no less than A VII (financial strength rating of no less than A and financial size category of no less than VII), unless specific prior written approval has been granted by VTA.

## APPENDIX B CONTRACT DATA REQUIREMENTS

Table B-1 represents only a partial listing of submittal requirements. The table is a reminder to Contractor of his responsibility to submit submittals in a timely manner.

Table B-2 Technical Submittals List follows Table B-1. The Technical Submittal List is intended to summarize the requirements for submittals as specified in the Contract Documents

Other submittals shall be required in accordance with the Technical Specifications. If conflicts exist between the lists and the referenced paragraph, the referenced paragraph will take precedence. Refer to Contract Section 6.6 for additional information and requirements for contract data submittals and technical submittals.

Per Section 7.30, all time periods measured in days shall be based upon calendar days unless specified otherwise.

**Table B-1 Contract Data List**

	Description	Reference Section	Due Date/Frequency
50001	Construction Agreement	2.3.2 Section 5	Within 6 working days following Notice of Award
50002	Performance Bond	2.3.2 6.3.2	“
50003	Payment Bond	2.3.2 6.3.1	“
50004	Certificate of Insurance	2.3.2 6.2 Appendix A	“
50005	Listing of Subcontractors, Suppliers and Subconsultants	2.3.2 Section 4	“
50006	IRS Form W-9	2.3.2 2.4	“
50007	FTB Form 587 or 590	2.3.2 2.4	“

Cerone Division Boiler & Propane Tank Replacement  
Contract C19123

	Description	Reference Section	Due Date/Frequency
50008	Not Used		
50009	Personnel to sign Change Orders	7.24	"
50010	Emergency Contacts	7.24	"
50011	EEO Officer-Contractor and all subcontractors.	Appendix C	"
50012	Safety Officer – Name and title.	6.14	"
50013	Prevailing Wages List	7.8	"
50014	Executed Subcontracts	7.18	Within 20 days following Notice of Award
50015	Certified Payrolls	7.58	Weekly
50016	Monthly MWBE/SBE Utilization Reports	Appendix C	Monthly
50017	Final MWBE/SBE Utilization Report	Appendix C	Prior to Final Payment

For technical documents, refer to Technical Submittals List below.

**Table B-2 Technical Submittals List**

Submittal #	Item	Reference	Due Date / Frequency	Comments
51001	Schedule of values	7.59 01 12 92	Within 6 days following Notice of Award	3 copies
51002	Baseline CPM schedule	6.21	Within 30 days following First Charge Day	3 copies
51003	Monthly schedule updates	6.21	Within 7 days following the end of the month.	3 copies
51004	Three-week look-ahead schedule	6.21	At every weekly progress meeting	10 copies
51005	Schedule revisions	6.21	As required	3 copies

Cerone Division Boiler & Propane Tank Replacement  
Contract C19123

Submittal #	Item	Reference	Due Date / Frequency	Comments
51006	Recovery schedules	6.21	Within 7 days of the schedule update that triggers the requirement	3 copies
51007	Time impact evaluations mitigation plans	6.21	Within 15 days of the circumstances that trigger the requirement	3 copies
51008	Monthly schedule updates	6.21	Within 7 days following the end of the month	3 copies
51009	Quality assurance plan	6.26 Appendix M	Within 20 days following Notice of Award	3 copies
51010	Site Specific Safety Plan (SSSP)	2.3.4 Appendix Q	Prior to issuance of NTP	3 copies
51011	Competent person's qualifications	Appendix Q	Within 7 Days of request by VTA	3 copies
51012	Access to material Safety Data Sheets (SDS) electronic file	6.14.3	Within 20 days following Notice of Award	3 copies
51013	Working drawings Shop drawings Product data Samples	7.43	Not less than 20 Working Days prior to related procurement, fabrication, assembly, installation, or testing.	3 copies
51014	ESCAPE (Erosion & Sedimentation Control Action Plan Element)	6.27 Appendix G	Within 5 days following Notice of Award	3 copies
51015	Industrial Illness & Injury Prevention Plan (IIPP)	2.3.4 Appendix Q	Prior to issuance of NTP	3 copies

Cerone Division Boiler & Propane Tank Replacement  
Contract C19123

Submittal #	Item	Reference	Due Date / Frequency	Comments
51016	Personal protective equipment for key VTA staff	6.14.5	Within 20 days following Notice to Proceed	4 complete sets
51017	Permit applications & supporting data	6.7 Appendix N	Within 2 weeks of submittal approval or request by VTA	3 copies
51018	Warranties	7.73	Before Final Acceptance	As specified
51019	Cutover Work Plan	6.11.8	At least 4 weeks prior to cutover date	3 copies
<b>DIVISION 01 - GENERAL REQUIREMENTS</b>				
51020	Site safety plans	6.14.1 Appendix Q 01 10 00	Within 20 days following Notice of Award	3 copies
51021	ESCAPE (Erosion & Sedimentation Control Action Plan Element)	6.27 Appendix G 01 10 00	Within 5 days following Notice of Award	3 copies
51022	Hazardous Materials Management Plan (HMMP)	01 10 00 02 80 00 - 1.07.B	30 days prior to commencing related work	3 copies
51023	Regulatory permits	6.7 Appendix N 01 10 00	As specified in Section 6.7	3 copies
51024	Manifests & bills of lading	01 10 00 02 41 19 - 1.07.C 02 80 00 - 1.07.G	Prior to Substantial Completion	3 copies
51025	Quality assurance plan	6.26 Appendix M 01 10 00 - 1.10.B	Within 20 days following Notice of Award	3 copies

Cerone Division Boiler & Propane Tank Replacement  
Contract C19123

Submittal #	Item	Reference	Due Date / Frequency	Comments
51026	Schedule of values	7.59 01 12 92	Within 10 days following Notice of Award	3 copies
51027	List of major subcontractors with areas of responsibility and tentative construction schedule / sequence.	01 31 19 - 1.03.B.2	At Pre-Construction Meeting	12 Copies
51028	Patching materials product data and samples	01 73 00 - 1.07.B	Min. 30 days prior to commencing related work	3 copies
51029	Traffic & pedestrian control plans	01 73 00 - 1.07.C	Min. 30 days prior to commencing related work	3 copies
51030	Utility bypass / relocation plans	01 73 00 - 1.07.D	Min. 30 days prior to commencing related work	3 copies
51031	Contractor's Substantial Completion preliminary punch list	01 77 00 - 1.04.A.1	Min. 7 days prior to date of requested Substantial Completion inspection	3 copies
51032	Startup testing / adjusting / balancing records and test reports	01 77 00 - 1.04.A.4.c	Prior to date of requested Substantial Completion inspection	3 copies
51033	Record Documents	01 77 00 - 1.04.A.4.d	Prior to date of requested Substantial Completion inspection	3 copies
51034	Written request for Substantial Completion inspection	01 77 00 - 1.04.B	Min. 7 days prior to date of requested Substantial Completion inspection	3 copies



Cerone Division Boiler & Propane Tank Replacement  
Contract C19123

Submittal #	Item	Reference	Due Date / Frequency	Comments
51035	Certified copy of Substantial Completion punch list	01 77 00 - 1.05.B	Min. 7 days prior to date of requested Final Completion inspection	3 copies
51036	Written request for Final Completion inspection	01 77 00 - 1.05.C	Min. 7 days prior to date of requested Final Completion inspection	3 copies
51037	Construction document management system system accounts	01 78 39 - 1.03.B.1	Within 30 days following First Charge Day	2 accounts
51038	Construction document management system field equipment	01 78 39 - 1.03.B.2	Within 30 days following First Charge Day	2 sets of required devices
51039	Re-lined Contract Documents - Vol. 1	01 78 39 - 1.03.C	Prior to Substantial Completion	3 hard copy sets
51040	Re-lined Contract Documents - Vol. 2 ("Contract Drawings")	01 78 39 - 1.03.D	Prior to Substantial Completion	3 half-size hard copy sets
51041	Re-lined shop drawings	01 78 39 - 1.03.E	Prior to Substantial Completion	3 half-size hard copy sets
51042	Operation & maintenance manuals	01 78 39 - 1.03.F	Prior to Substantial Completion	3 hard copy sets
51043	Warranties	01 78 39 - 1.03.G	Prior to Substantial Completion	3 hard copy sets
51044	Regulatory applications and permits	01 78 39 - 1.03.H	Prior to Substantial Completion	3 hard copy sets
51045	Test and inspection reports	01 78 39 - 1.03.I	Prior to Substantial Completion	3 hard copy sets

Cerone Division Boiler & Propane Tank Replacement  
Contract C19123

Submittal #	Item	Reference	Due Date / Frequency	Comments
51046	Pre-construction site photos (Pre-construction copy)	01 78 39 - 1.03.J.1	Prior to commencing construction, and no later than 7 days after NTP	3 USB drives
51047	Pre-construction site photos (Record copy)	01 78 39 - 1.03.J.2	Prior to Substantial Completion	On record document USB drives
51048	Construction progress photos	01 78 39 - 1.03.K	Prior to Substantial Completion	On record document USB drives
51049	Electronic record document submittal (USB storage drives)	01 78 39 - 1.03.L	Prior to Substantial Completion	3 sets of USB storage drives
<b>DIVISION 02 - EXISTING CONDITIONS</b>				
51050	Proposed potholing excavation equipment	02 32 19 - 1.04.B	30 days prior to commencing related work	3 copies
51051	Preliminary pothole plan	02 32 19 - 1.04.C	30 days prior to commencing related work	3 copies
51052	Pothole reports	02 32 19 - 1.04.D	Within 2 business days of completion	3 copies
51053	Selective demolition schedule	02 41 19 - 1.07.B	30 days prior to commencing related work	3 copies
51054	Landfill / recycler receipts and weight tickets	02 41 19 - 1.07.C.1 & 3.08.A	Within 2 business days of completion	3 copies
51055	Completed Waste Manifests	02 41 19 - 1.07.C.2 & 3.08.A	Within 2 business days of completion	3 copies
51056	Disposal records	02 41 19 - 1.07.C.3 & 3.06.C	Within 2 business days of completion	3 copies

Cerone Division Boiler & Propane Tank Replacement  
Contract C19123

Submittal #	Item	Reference	Due Date / Frequency	Comments
51057	Personnel / subcontractor qualifications for hazmat AST closure / removal	02 80 00 - 1.07.B & 1.05	30 days prior to commencing related work	3 copies
51058	Hazmat AST closure / removal related permits	02 80 00 - 1.07.C & 1.06	30 days prior to commencing related work	3 copies
51059	Tank closure certification form	02 80 00 - 1.07.D	30 days prior to commencing related work	3 copies
51060	Training & PPE for VTA Staff	02 80 00 - 1.07.E	30 days prior to commencing related work	3 copies
51061	Hazardous Materials Management Plan (HMMP)	02 80 00 - 1.07.F	30 days prior to commencing related work	3 copies
51062	Hazardous materials removal closeout submittals	02 80 00 - 1.07.G & 3.06.A	Prior to Substantial Completion	3 copies
<b>DIVISION 03 - CONCRETE</b>				
51063	Concrete forming product data	03 10 00 - 1.04.B	30 days prior to commencing related work	3 copies
51064	Concrete formwork material product data	03 10 00 - 1.04.C	30 days prior to commencing related work	3 copies
51065	Concrete joint layout drawings	03 10 00 - 1.04.D	30 days prior to commencing related work	3 copies
51066	Concrete formwork shop drawings	03 10 00 - 1.04.E	30 days prior to commencing related work	3 copies
51067	Concrete reinforcement shop drawings	03 20 00 - 1.04.B	30 days prior to commencing related work	3 copies
51068	Concrete reinforcement product data	03 20 00 - 1.04.C	30 days prior to commencing related work	3 copies

Cerone Division Boiler & Propane Tank Replacement  
Contract C19123

Submittal #	Item	Reference	Due Date / Frequency	Comments
51069	Concrete reinforcement mill certs	03 20 00 - 1.04.D	30 days prior to commencing related work	3 copies
51070	Concrete reinforcement testing agency qualifications	03 20 00 - 1.04.E	30 days prior to commencing related work	3 copies
51071	Concrete reinforcement test and inspection reports	03 20 00 - 1.04.F	Prior to placing steel	3 copies
51072	Concrete reinforcement welder's certificates	03 20 00 - 1.04.G	30 days prior to commencing related work	3 copies
51073	Concrete reinforcement Welding Procedure Specifications (WPS)	03 20 00 - 1.04.G	30 days prior to commencing related work	3 copies
51074	Cast-in-place concrete product data	03 30 00 - 1.04.B	60 days prior to commencing related work	3 copies
51075	Cast-in-place concrete mix designs	03 30 00 - 1.04.C	60 days prior to commencing related work	3 copies
51076	Cast-in-place concrete placement schedule	03 30 00 - 1.04.D	60 days prior to commencing related work	3 copies
51077	Cast-in-place concrete certificates of compliance	03 30 00 - 1.04.E	60 days prior to commencing related work	3 copies
51078	Cast-in-place concrete weight and batch tags	03 30 00 - 1.04.F	1 Copy upon delivery of materials, 2 more copies within 2 business days	3 copies
51079	Contractor's testing agency qualifications	03 30 00 - 1.04.G	60 days prior to commencing related work	3 copies
51080	Testing agency's cast-in-place concrete test and inspection reports	03 30 00 - 1.04.H	Within 2 business days of test / inspection	3 copies

Cerone Division Boiler & Propane Tank Replacement  
Contract C19123

Submittal #	Item	Reference	Due Date / Frequency	Comments
<b>DIVISION 09 - FINISHES</b>				
51081	Painting product data	09 91 23 - 1.03.B	30 days prior to commencing related work	3 copies
51082	Painting samples	09 91 23 - 1.03.C	30 days prior to commencing related work	3 copies
<b>DIVISION 23 - HEATING, VENTILLATION, &amp; AIR CONDITIONING</b>				
51083	Welding certificates	23 11 26 - 1.04.B	30 days prior to commencing related work	3 copies
51084	Field quality control test & inspection reports	23 11 26 - 1.04.C	Within 2 business days of test / inspection	3 copies
51085	LPG Gas piping system product data	23 11 26 - 1.04.D	30 days prior to commencing related work	3 copies
51086	LPG Gas piping system shop drawings	23 11 26 - 1.04.E	30 days prior to commencing related work	3 copies
51087	LPG Gas piping fusion procedure	23 11 26 - 1.04.F	30 days prior to commencing related work	3 copies
51088	LPG Cleaning and purging plan	23 11 26 - 1.04.G & 1.08.A.1	30 days prior to commencing related work	3 copies
51089	LPG Gas piping system operation & maintenance data	23 11 26 - 1.04.H.1	Prior to Substantial Completion	3 copies
51090	LPG Gas piping system warranty certificates	23 11 26 - 1.04.H.2	Prior to Substantial Completion	3 copies
51091	LPG Storage tank system product data	23 13 23 - 1.04.B	30 days prior to commencing related work	3 copies
51092	LPG Storage tank system shop drawings	23 13 23 - 1.04.C	30 days prior to commencing related work	3 copies

Cerone Division Boiler & Propane Tank Replacement  
Contract C19123

Submittal #	Item	Reference	Due Date / Frequency	Comments
51093	LPG Storage tank system seismic qualification certificates	23 13 23 - 1.04.D	30 days prior to commencing related work	3 copies
51094	LPG Storage tank system brazing certificates	23 13 23 - 1.04.E	30 days prior to commencing related work	3 copies
51095	LPG Storage tank system welding certificates	23 13 23 - 1.04.F	30 days prior to commencing related work	3 copies
51096	LPG Storage tank system factory test & inspection reports	23 13 23 - 1.04.G	14 days prior to shipment from manufacturer	3 copies
51097	LPG Storage tank system field test & inspection reports	23 13 23 - 1.04.H	Within 2 business days of completion	3 copies
51098	LPG Storage tank system example / sample warranty	23 13 23 - 1.04.I	30 days prior to commencing related work	3 copies
51099	LPG AST Telemetry monitoring system installation drawings & instructions	23 13 23 - 1.04.J	30 days prior to commencing related work	3 copies
51100	LPG AST Telemetry programming equipment	23 13 23 - 1.04.K	Prior to Substantial Completion	1 complete set of required equipment
51101	LPG Storage tank system operation & maintenance data	23 13 23 - 1.04.L.1	Prior to Substantial Completion	3 copies
51102	LPG Storage tank manufacturer's certification letter	23 13 23 - 1.04.L.2	Prior to Substantial Completion	3 copies
51103	LPG Storage tank system warranty certificates	23 13 23 - 1.04.L.3	Prior to Substantial Completion	3 copies
<b>DIVISION 26 - ELECTRICAL</b>				
51104	Conductor & cable - product data	26 05 19 - 1.03.B	30 days prior to commencing related work	3 copies

Cerone Division Boiler & Propane Tank Replacement  
Contract C19123

Submittal #	Item	Reference	Due Date / Frequency	Comments
51105	Conductor & cable - shop drawings	26 05 19 - 1.03.C	30 days prior to commencing related work	3 copies
51106	Conductor & cable - field test & inspection reports	26 05 19 - 1.03.D	Within 2 business days of completion	3 copies
51107	Grounding & bonding - product data	26 05 26 - 1.03.B	30 days prior to commencing related work	3 copies
51108	Grounding & bonding - shop drawings	26 05 26 - 1.03.C	30 days prior to commencing related work	3 copies
51109	Grounding & bonding - field test & inspection reports	26 05 26 - 1.03.D	Within 2 business days of completion	3 copies
51110	Grounding & bonding - project record documents	26 05 26 - 1.03.E	Prior to Substantial Completion	3 copies
51111	Hangers & supports - product data	26 05 29 - 1.04.B	30 days prior to commencing related work	3 copies
51112	Hangers & supports - shop drawings	26 05 29 - 1.04.C	30 days prior to commencing related work	3 copies
51113	Raceways & boxes - product data	26 05 33 - 1.04.B	30 days prior to commencing related work	3 copies
51114	Raceways & boxes - shop drawings - enclosures & cabinets	26 05 33 - 1.04.C	30 days prior to commencing related work	3 copies
51115	Raceways & boxes - coordination drawings	26 05 33 - 1.04.D	30 days prior to commencing related work	3 copies
51116	Raceways & boxes - qualification data	26 05 33 - 1.04.E	30 days prior to commencing related work	3 copies
51117	Raceways & boxes - seismic qualification certificates	26 05 33 - 1.04.F	30 days prior to commencing related work	3 copies



Cerone Division Boiler & Propane Tank Replacement  
Contract C19123

---

<b>Submittal #</b>	<b>Item</b>	<b>Reference</b>	<b>Due Date / Frequency</b>	<b>Comments</b>
51118	Sleeves & sleeve seals - product data	26 05 44 - 1.03.B	30 days prior to commencing related work	3 copies
51119	Electrical identification - product data	26 05 53 - 1.04.B	30 days prior to commencing related work	3 copies
51120	Electrical identification - samples	26 05 53 - 1.04.C	30 days prior to commencing related work	1 sample of each type
51121	Electrical identification - schedules	26 05 53 - 1.04.D	30 days prior to commencing related work	3 copies

*[End of Appendix B]*

*[This Page Intentionally Left Blank]*

## APPENDIX C BUSINESS DIVERSITY POLICY AND REQUIREMENTS

### Table of Contents

1.1	Policy.....	1
1.2	SBE Participation Goal.....	2
1.3	Counting SBE Participation toward the Goal .....	2
1.4	Certification.....	2
1.4.1	Firms Certified.....	2
1.4.2	Expired Certification .....	2
1.5	Bid Submittals .....	3
1.5.1	Bid Form 4.....	3
1.5.2	Bid Form 5.....	3
1.5.3	Good Faith Effort .....	3
1.6	Award of the Contract.....	3
1.7	Compliance .....	3
1.8	Good Faith Efforts .....	3
1.8.1	General.....	3
1.8.2	Good Faith Criteria.....	4
1.8.3	Presumption.....	6
1.8.4	Verification of Information .....	6
1.9	Commitment .....	7
1.10	Non-Discrimination .....	7
1.11	Substitution of SBE Subcontractors by non-SBE Contractor .....	7
1.11.1	Prior Written Consent.....	7
1.11.2	Substitution Process .....	7
1.11.3	Penalty .....	8
1.12	Reports.....	8
1.12.1	Monthly SBE Utilization Report .....	8
1.12.2	Final SBE Utilization Report .....	8
1.12.3	Failure to Submit Reports .....	8
1.13	Change Orders, Extra Work and Allowances .....	8
1.14	Prompt Payment .....	9

---

### **1.1 Policy**

It is the policy of Santa Clara Valley Transportation Authority (VTA) to ensure that Small Business Enterprises (SBE) as defined in federal regulations at 13 CFR Part 121 have the opportunity to participate in the performance of contracts and subcontracts financed with local funds.

Any certified DBE is eligible to participate as a SBE toward the SBE participation goal.

VTA's Office of Business Diversity Program encourages Contractors to call (408) 321-5962 for assistance in identifying eligible SBE firms. Listings of eligible firms are also available on the following website:

<http://www.vta.org/About-Us/Inside-VTA/Small-Business-Enterprise-Program>

<https://dot.ca.gov/programs/business-and-economic-opportunity/dbe-search>

<https://www.caleprocure.ca.gov/pages/PublicSearch/supplier-search.aspx>

## **1.2 SBE Participation Goal**

A SBE participation goal has been established as stated in the Invitation for Bid and the Bid Forms for this Contract.

## **1.3 Counting SBE Participation toward the Goal**

SBE firms may perform as prime contractors, subcontractors to a prime (1st tier), or subcontractor to subcontractor (2nd tier). Only the value of the work actually performed by the SBE, including materials and supplies, will be counted toward the SBE participation goal.

A SBE must perform a commercially useful function; i.e., must be responsible for the execution of a distinct element of the work and must carry out its responsibility by actually performing, managing and supervising the work. If a SBE does not perform or exercise responsibility of at least 30% of the total cost of its contract with its own work force, or if the SBE subcontracts a greater portion of work of a contract than would be expected on the basis of normal industry practice, then it will be presumed that the SBE is not performing a commercially useful function.

Credit for a SBE vendor of materials or supplies is limited to 60% of the amount to be paid to the vendor for the materials or supplies unless the vendor manufactures or substantially alters the goods. Credit for SBE brokers is limited to only the fees and commissions portion of the amount paid. All other firms receive 100% credit, less work subcontracted by the SBE to non-SBE firms, toward the SBE goal.

Credit for SBE trucking firms is limited to the amount performed by the SBE's own trucks and drivers and by certified SBE trucking subhaulers. A SBE trucking firm must itself own and operate at least one fully licensed, insured and operational truck used on the contract.

In a joint venture, only the portion of the total dollar value of the Contract equal to the distinct, clearly-defined portion of the Work of the Contract that the SBE performs with its own forces will be counted toward the SBE goal.

Bidders are encouraged to utilize services offered by financial institutions owned and controlled by socially and economically disadvantaged individuals in VTA's community and marketplace.

## **1.4 Certification**

### **1.4.1 Firms Certified**

All SBE firms listed on the Bid Forms must be certified by at the time of Bid to be counted toward the SBE participation goal. Contractor shall utilize the following sources for identifying certified SBE firms for solicitation: California Unified Certification Program (CUCP) database; California Department of General Services Small Business database (Caleprocure); VTA SBE database.

### **1.4.2 Expired Certification**

During the life of a contract, work performed by SBE firms whose certification has expired will not continue to be counted toward the SBE participation goal. Only work performed by a certified SBE firm will be counted toward the SBE participation goal when the SBE firm has been paid.

## **1.5 Bid Submittals**

### **1.5.1 Bid Form 4**

Bid Form 4 lists SBE Bidder plus the subcontractor(s) or supplier(s) Bidder intends to use and count toward the SBE participation goal, with a complete description of services or supplies to be provided by each, work which the SBE further subcontracts to non-SBE firms, and the dollar value of each such subcontracting or supplies transaction. Instructions for completing the form are provided on the form.

### **1.5.2 Bid Form 5**

Bid Form 5 is Supplemental Contractor and Subcontractor information. Instructions for completing the form are provided on the form.

### **1.5.3 Good Faith Effort**

A Bidder not achieving the SBE participation goal must submit a report documenting that it made sufficient efforts to meet the SBE participation goal. Documentation of Good Faith Effort must be provided in accordance with **Appendix C Section 1.8 Good Faith Efforts**.

## **1.6 Award of the Contract**

VTA will award this Contract to the lowest responsible and responsive bidder as required by federal and California laws and VTA SBE policy.

Following the bid opening and submittal of all documentation, VTA will evaluate all bids and required information submitted by bidders to formulate a recommendation for award of the Contract. The bidder with the lowest bid price who also meets the specified SBE participation goal or demonstrates that sufficient good faith efforts, for those contracts with a specific goal vs. non-specific goal (NSG), were made to meet the specified SBE participation goal will be deemed the lowest responsible and responsive bidder.

## **1.7 Compliance**

VTA will advise Bidder of its compliance with the contract SBE participation goal or with the good faith efforts documentation requirements.

## **1.8 Good Faith Efforts**

### **1.8.1 General**

To determine whether a Bidder that has failed to meet the SBE participation goal may be awarded the Contract, VTA will decide whether the Bidder made adequate “good faith efforts”, where applicable, to meet the goal.

“Good faith efforts” means all necessary and reasonable steps to achieve the SBE participation goal which by their scope, intensity and appropriateness, could reasonably be expected to fulfill the goal. Only those efforts made prior to Bid Opening will be considered in evaluating good faith efforts. Mere *pro forma* efforts are not sufficient good faith efforts to meet the SBE contract requirements.

Bidders are expected to be directly responsible for performing the good faith efforts requirements of this Contract. Bidder’s use of third parties to support its good faith efforts is at Bidder’s own risk and does not relieve the Bidder from being responsible for meeting the good faith efforts requirements.

VTA may request ancillary or omitted documentation required to complete Bidder's good faith efforts submittal.

### **1.8.2 Good Faith Criteria**

The criteria listed below are reflective of good faith efforts undertaken by a Bidder actively and aggressively seeking to meet the goal:

- (a) **Pre-Bid Meeting.** Bidder attended any pre-solicitation or pre-Bid meetings that were scheduled by VTA to inform Bidders of the Small Business Enterprise Program requirements for this Contract. VTA may waive this requirement if it determines from the documentation submitted that Bidder is informed as to those program requirements.
- (b) **Identification of SBE Participation Opportunities.** Bidder identified and selected specific items of the Work to be performed by SBE firms to provide genuine opportunities for participation by SBE firms. Bidder shall provide documentation showing the items that were identified and selected and shall describe how such items were utilized by Bidder to solicit SBE participation. Where appropriate, Bidder should be able to show that Bidder broke out Contract work to facilitate SBE participation, even when Bidder preferred to perform this portions of the Work with its own forces.
- (c) **Advertisements.** At least ten calendar days<sup>1</sup> before the Bid Opening, Bidder solicited sub-bids from SBE firms for specified categories of work or materials or supplies for the contract through advertisements (not simply the listing of planholders) placed in two or more of the following media, one of which shall be from each of the following two categories:

#### **Category I**

Daily Pacific Builder  
300 American Metro Blvd., Suite 185  
Hamilton, NJ 08619  
(888) 814-0513

OR

Daily Construction Service  
P. O. Box 1748  
Glen Ellen, CA 95442  
Email: vicki.darmiento@cmdgroup.com  
(800) 242- 9747

#### **Category II**

Small Business Exchange  
795 Folsom Street, First Floor  
San Francisco, CA 94107  
(415) 778-6250

---

<sup>1</sup> The time of requirements for advertising [Section 7.1c)] and written notice [Section 7.1d)] shall apply only those contracts for which VTA has issued public notice of the contract at least 15 calendar days prior to bid opening.

- (d) **Written Notice.** At least ten calendar days before the Bid Opening, Bidder provided written notice to a sufficient number of SBE certified firms in each subcontracting work category, and to such firms in each category of materials or supplies for the project. Written notice to a minimum of ten (10) firms shall constitute a sufficient number of firms to be notified if the approved databases contain at least 10 firms for that category.

Written notice shall be sent first to “local firms”, then, where none are available or remain, to out-of-area firms. “Local” shall mean Santa Clara County and its contiguous counties, as well as Sacramento and San Joaquin Counties.

- (e) **Follow-up of Initial Solicitations.** Bidder followed up initial solicitations of interest by contacting the SBE firms to determine with certainty whether the firms were interested in bidding on the project. Such follow-up activity shall be documented with telephone and or fax logs or other written documentation that shall be submitted to VTA and that shall set forth, at a minimum, the following information:

- The type of contact; i.e., telephone, meeting, letter, fax, or e-mail;
- The name of the SBE firm contacted;
- The date and time the SBE firm was contacted;
- The full name, title, telephone or fax number, and e-mail address of the person at the SBE firm contacted by Bidder;
- The responses of each of the SBE firms contacted with regard to its interest in submitting a sub-bid; and
- For each SBE firm contacted that declined to bid, the reason(s) provided by the SBE firm for declining to bid.

- (f) **Information Regarding Plans, Specifications, and Requirements.** Bidder provided interested SBE firms with information about the plans, specifications and requirements for selected subcontracting or materials or supplies work. Bidder shall describe the information provided to interested firms, report the name of the firms involved, and set forth the date and method of providing such information.

- (g) **Request for Assistance in the Recruitment of SBE Firms.** Bidder requested assistance from federal, state, and local agencies for lists of SBE firms, as accepted or approved by VTA, on a case-by-case basis. Bidder is responsible for receiving approval from VTA prior to listing SBE firms of other agencies not certified or approved by VTA. Bidder shall state the agencies contacted, names of persons contacted, date and method of contact and results of contacts.

- (h) **Good-Faith Evaluation of and Negotiation with Interested SBE Firms.** Bidder evaluated the proposals of and negotiated in good faith with interested SBE firms, and did not unjustifiably reject SBE firm(s) as unsatisfactory or unqualified without sound reasons based on a thorough assessment of the capabilities of the firm(s) in question. Bidder shall list all SBE responses to the solicitation, and all SBE sub-bids which were received but not used. **NOTE: If no SBE bids are received, this fact must be stated.** Bidder shall provide, at a minimum, the following information:

- The names, addresses and telephone and fax numbers of SBE firms, including full name and title of the contact person at the SBE firm who responded to the solicitation or submitted sub-bids;



- A summary of the discussions and negotiations between Bidder and each such firm;
- If a bid is rejected by Bidder, the reasons for the rejection;
- A copy of all rejected SBE sub-bids, along with copies of all bids received by non-SBE firms for the same or similar scope of work. If the rejected SBE sub-bids or the other bids received are not in writing, Bidder shall set forth the amount of each such sub-bid or other bid, together with a description of the work bid upon for each; and
- If Bidder rejected a SBE as unqualified, a description of the assessment conducted by Bidder prior to reaching such conclusion.

The ability of or desire of a prime Contractor to perform the Work with its own firm does not relieve the Bidder of the responsibility to make sufficient good faith efforts. Prime Contractors are not required to accept higher quotes from SBE firms if the price difference is excessive or unreasonable when compared to industry standards.

- (i) **Advice and Assistance to Interested SBE Firms.** Bidder advised and made efforts to assist those SBE firms requesting help in obtaining bonds, lines of credit or insurance required by VTA or Bidder. Assistance may include, but is not limited to:

- Contacting bonding and/or insurance companies on behalf of a SBE firm;
- Arranging with sureties phased or incremental bonding for the SBE firm;
- Waiving bonds or insurance requirements;
- Referring SBE firms to resource agencies which may assist SBE firms to obtain bonding, insurance or lines of credit, such as the Small Business Administration (SBA); or
- Making efforts to assist interested SBE firms in obtaining necessary equipment, supplies, materials, or related assistance or services.

Bidder shall state whether any such advice or assistance was given and to whom, the dates of any such advice or assistance, and a description of the advice or assistance provided.

- (j) **Efforts to Obtain SBE Firms Could Reasonably Be Expected to Meet Goals.** Bidder's efforts to obtain SBE firm participation could reasonably be expected by VTA to produce a level of participation sufficient to meet the goals and requirements of VTA. Bidder shall provide any additional data to support a demonstration of good faith efforts to produce the level of SBE participation sufficient to meet the goal for this Contract.

- (k) **Performance of Other Bidders to be Taken into Account.** The performance of other Bidders in meeting the SBE participation goal may be taken into account by VTA. If, for example, the apparent low Bidder fails to meet the SBE participation goal but other Bidders meet the goal, this may be taken into consideration in considering whether the apparent low Bidder made good faith efforts to meet the goal.

### 1.8.3 Presumption

Satisfaction of the criteria above will create a rebuttable presumption that Bidder has made an adequate good faith effort to comply with the goal and requirements of VTA for SBE participation for this Contract.

### 1.8.4 Verification of Information

VTA may verify the accuracy or completeness of any or all of the documentation submitted by Bidder by directly contacting the listed SBE firms or through other means.

## **1.9 Commitment**

The SBE Goal Achieved in the approved Bid Form 4 equates to a commitment from the Contractor. The Contractor must meet this commitment ("SBE Commitment") regardless of the participation goal stated during Contract advertisement.

## **1.10 Non-Discrimination**

Contractor shall make VTA's contracting requirements known to subcontractors, vendors and suppliers who are certified or accepted as certifiable as a SBE firm, as well as to non-SBE firms, and shall provide a practical opportunity for all firms to participate in this Contract.

## **1.11 Substitution of SBE Subcontractors by non-SBE Contractor**

### **1.11.1 Prior Written Consent**

A SBE subcontractor or supplier shall not be replaced without the prior written consent of VTA.

### **1.11.2 Substitution Process**

Contractor shall make good faith efforts to find another SBE subcontractor or supplier to substitute for the original SBE that is unwilling or unable to perform the Work. The efforts employed by the Contractor shall be those that one could reasonably expect a Contractor to take if the Contractor were actively and aggressively trying to engage a certified SBE firm to substitute for a SBE firm that has to be replaced and shall include the following:

- (a) Contractor shall immediately notify VTA in writing of its intent to replace a SBE firm, and of the reasons therefore, prior to any solicitation or advertisement for replacement firms. A copy of the notice shall be provided to the VTA Office of Business Diversity Program (OBDP).
- (b) VTA will provide written notice to the SBE firm of Contractor's request for substitution and of the reasons therefore and they will be requested to provide any written objections within five working days.
- (c) Contractor shall utilize the following sources for identifying certified SBE firms for solicitation: California SBE Uniform Certification Program database.
- (d) Contractor shall provide written notice to at least five firms in each work or material/supply category to be substituted. If Contractor provides written notice to less than five firms Contractor shall explain to OBDP in writing why the number of firms solicited was sufficient. Written notice shall be sent first to firms located in the County of Santa Clara and its contiguous counties as well as Sacramento and San Joaquin counties ("local firms") and then, where appropriate, to out-of-area SBE firms.
- (e) Contractor shall contact the SBE firms solicited to determine with certainty whether the firms are interested in bidding on the project. This follow-up shall be documented with telephone logs, fax logs or other written documentation and submitted to OBDP.
- (f) Contractor shall provide OBDP with the following information:
  - A list and copies of all SBE and non-SBE responses to the solicitation, including all bids received;

- If a bid is rejected by Contractor, the reasons for the rejection;
- If Contractor rejected a SBE firm as unqualified, a description of the qualification assessment conducted by Contractor and the factors considered.

### **1.11.3 Penalty**

A Contractor who fails to use good faith efforts to replace a SBE firm with another SBE firm may be subject to the imposition of a penalty of up to 15% of the value of the work of the subcontractor or supplier replaced.

## **1.12 Reports**

### **1.12.1 Monthly SBE Utilization Report**

Contractor must submit monthly SBE Utilization Reports electronically to the SBE Administrator, VTA Office of Business Diversity Programs. These monthly reports shall be submitted electronically and the Contractor will document the dollar value of payments to SBE firms, and the percentage of the Contract completed. VTA will monitor the Contract for compliance with SBE requirements.

This system is web-based, accessible from any computer via the internet at: <https://vta.sdbbe.com>.

Contractor and each subcontractor will receive an email providing them with Log On identification, and a temporary password and instructions on how to use the system. Classroom training will also be provided. Other assistance will be provided upon request.

Contractor will include this requirement in all of its subcontracts and purchase orders when required to provide or verify SBE utilization documentation.

If the SBE Utilization Reports indicate potential problems, such as a failure to meet the SBE Commitment, the Contractor shall meet with the appropriate VTA representative(s) to address any deficiencies and discuss appropriate corrective actions. When the Contract completion reaches 50% and the SBE utilization percentage participation goal completed is less than 50% of the SBE Commitment, a detailed report of the reasons why must be submitted to VTA stating a plan to reach the SBE Commitment by Contract completion.

### **1.12.2 Final SBE Utilization Report**

Prior to final payment, Contractor will be required to submit a final SBE Utilization Report. In addition to payments to the SBEs, the final report must include payments to and other information about all other businesses, including non-SBE subcontractors, suppliers of materials, trucking firms, consultants and others.

### **1.12.3 Failure to Submit Reports**

Failure by Contractor to submit required reports as described above may be considered grounds for a determination by VTA of non-responsibility in consideration of Contractor's eligibility to bid on or be awarded future work.

## **1.13 Change Orders, Extra Work and Allowances**

Including all change or extra work and allowances, Contractor shall maintain the contractual SBE goal throughout the life of the Contract or make good faith efforts to meet the SBE participation goal.

#### **1.14 Prompt Payment**

Contractor must adhere to all Federal and California prompt payment laws and regulations. See also 7.61, Prompt Payment. If Contractor does not adhere to prompt payment requirements, penalties may apply.

*[This Page Intentionally Left Blank]*

## APPENDIX G ENVIRONMENTAL COORDINATION AND COOPERATION

The following requirements of this Appendix G apply to this Project if the box next to the requirement is checked:

- 1.1 Tree Removal
- 1.2 Archaeological Sensitive Area
- 1.3 Archaeological/Historical Discoveries
- 1.4 Environmentally Sensitive Areas
- 1.5 Mitigation Measures
- 1.6 Migratory Nesting Birds and Roosting Wildlife
- 1.7 Sudden Oak Death
- 1.8 Storm Water Pollution Prevention Plan (SWPPP)
- 1.9 Erosion and Sedimentation Control Action Plan Element (ESCAPE)
- 1.10 Water Pollution Control Program (WPCP)
- 1.11 Construction Water Conservation

Attachments to this Appendix are included if the box next to the listed attachment is checked:

- Attachment G1 Sample regulatory agency permits *or* Regulatory agency permits
- Attachment G2 ESCAPE Template

## 1.1 Archeological/Historical Discoveries

**1.1.1** Should any archaeological or historical artifacts or skeletal material be discovered or unearthed during construction activities, all work within ten meters of the find shall be halted. Contractor, Subcontractor, Engineer or inspector as appropriate, shall immediately notify VTA, and VTA will initiate procedures in accordance with 36 CFR 800.11, California Public Resources Code Section 5097.98, and Santa Clara County Ordinance Code Sections B6-16 through B6-23. Construction activities within ten meters of the find shall remain halted until authorization is obtained from VTA that construction in the vicinity of the find may resume.

**1.1.2** In the event of work suspension pursuant to this section, Contractor shall, within 24 hours, notify VTA of the costs involved resulting from said work stoppage. Contractor shall maintain a log of each such stoppage of work, setting forth the date and time of notification of work stoppage, date and time of actual cessation of operations in the area, and date and time of commencement of operations and costs incurred herein. Contractor shall submit a claim for reimbursement of such costs within 72 hours thereof and shall notify VTA of the anticipated amount of claim within 24 hours of said work suspension. In the event of work suspension hereunder, Contractor shall exert all reasonable efforts to otherwise utilize labor and equipment affected by the suspension in other portions of the project.

## 1.2 Erosion and Sedimentation Control Action Plan Element (ESCAPE)

**1.2.1** VTA, being the owner of the site where the subject construction activity is to occur, is responsible for preventing and/or mitigating potential chemical releases, erosion and sedimentation impacts associated with stormwater runoff. VTA has established an Erosion and Sedimentation Control Action Plan Element (ESCAPE) for storm water discharge associated with construction activity.

**1.2.2** Using the template provided and included in this Appendix G, Contractor shall prepare and submit an ESCAPE for the subject site to VTA for review and approval **within five (5) working days following Notice of Award of Contract**.

- (a) Contractor shall clearly identify its construction activities and those of its subcontractors and the manner in which Contractor will ensure their compliance with VTA approved ESCAPE.
- (b) The ESCAPE shall be prepared consistent with the provisions of the National Pollution Discharge Elimination System (NPDES), General Permit No. CAS000002 for Storm Water Discharges Associated with Construction And Land Disturbance Activities adopted by the State Water Resources Control Board on September 2, 2009 as Order No. 2009-0009-DWQ. In that the area on which the Work shall be conducted plus the construction laydown/staging area(s) are **less than one acre in size**, a Notice of Intent is not required for submission by VTA to the Regional Water Quality Control Board.
- (c) VTA will provide review comments to Contractor **within five (5) working days** after receipt of the ESCAPE for any necessary revision and preparation of the final document.
- (d) Contractor shall return a final ESCAPE document to VTA **within two (2) working days** of receipt of VTA comments.



**1.2.3** At a minimum, the ESCAPE must address the following Best Management Practices (BMPs) in the **California Storm Water Best Management Practice Handbook for Construction Activity** prepared by the California Storm Water Quality Association (“CASQA”) for the California State Water Resources Control Board. This is available online at CASQA’s website. Contractor must be a member or subscriber of CASQA to access this handbook.

- WM-1, Material Delivery and Storage
- WM-2, Material Use
- WM-3, Stockpile Management
- WM-4, Spill Prevention and Control
- WM-5, Solid Waste Management
- WM-7, Contaminated Soil Management
- NS-3 Paving and Grinding Operations
- WM-8, Concrete Waste Management
- NS-8 & 9, Vehicle and Equipment Fueling, Cleaning and Maintenance
- SS-2, Preservation of Existing Vegetation
- WE-1, Wind Erosion Control
- SE-1, Silt Fence
- SE-5, Fiber Rolls
- SE-9, Straw Bale Barriers
- SE-10, Storm Drain Inlet Protection

**1.2.4** Contractor shall provide copies of the approved ESCAPE to its subcontractors and shall keep a copy available at the subject site. Contractor shall provide amendments to the ESCAPE whenever there is a change in construction, operations, or where storm water run-off conditions which may affect the discharge of significant quantities of pollutants to surface waters, groundwater, or separate municipal storm sewer systems. The amended ESCAPE shall be submitted to VTA for review and approval as soon as practical and Contractor shall retain the amended ESCAPE onsite.

**1.2.5** Contractor is advised that preparation and implementation of a VTA approved ESCAPE does not relieve Contractor or its subcontractor(s) of their responsibilities to comply with other state, county, and local governmental requirements, including those for storm water management or non-point source runoff controls.

**1.2.6** Full compensation for conforming to the requirements of this section shall be paid for as described in the Schedule of Quantities and Prices (SQP).

*[This Page Intentionally Left Blank]*

**ATTACHMENT G2 ESCAPE TEMPLATE ONLY**

**Erosion and Sediment Control Action Plan Element  
(ESCAPE)**

for

**CERONE DIVISION BOILER & PROPANE TANK REPLACEMENT  
CONTRACT C19123**

Prepared for

The Santa Clara Valley Transportation Authority (VTA)

Submitted by

Project Address

Preparation Data

# ATTACHMENT G2 ESCAPE TEMPLATE ONLY

## A. INTRODUCTION

The proposed project is located in all VTA Facilities. The preparation of the ESCAPE is based on the principal of Best Management Practices, not numeric effluent limitations, to control and abate the discharge of pollutants in storm water discharges. This ESCAPE is dynamic, viable, and will be modified and amended when there is a change in the construction or operations which may affect the discharge of storm waters from the construction site to the receiving waters.

TYPE OF PROJECT	[LANDSCAPING]
CONSTRUCTION LIMITS:	[FROM_]
DURATION:	[MONTH, YEAR]
START DATE:	[MONTH, DAY, YEAR]
END DATE:	[MONTH, DAY, YEAR]
CONTRACTOR:	[NAME]

These documents are available for review by any interested party during the normal working hours at:

[LOCATION]

[ADDRESS]

## B. PURPOSE

The purpose of this Erosion and Sedimentation Control Plan Element:

1. Identify pollutant sources that may affect the quality of discharges of storm water associated with the construction activities of the project.
2. Identify, construct, and implement storm water pollution prevention measures to reduce pollutants in storm water discharges from the construction site during construction and post construction.
3. Document erosion control, sediment control, wind erosion, tracking control, and non-storm water management, and waste management and pollution control. Best Management Practices (BMPs) that must be implemented year round as appropriate based on construction activities. The ESCAPE may require modification as the project progresses and as conditions warrant. All modifications to the approved ESCAPE must be submitted to VTA for review and approval.

## C. OBJECTIVE

The objective of this ESCAPE is to minimize the degradation of off-site water receiving waters to the extent possible by identifying, constructing, and implementing storm water pollution prevention measures, with the current Best Management Practices, before, during, and post construction.

# ATTACHMENT G2 ESCAPE TEMPLATE ONLY

## D. SOURCE POLLUTANT IDENTIFICATION

1. Include a Site map with:
  - a. Areas of soil disturbance
  - b. Drainage pattern and slopes anticipated after grading activities are completed
  - c. Locations of controls such as: sandbags, inlet protections, concrete washout, check dams, etc.
  - d. Areas and plan for storage and waste, including toxic/chemical materials
  - e. Staging, trailer, and construction equipment locations.
  - f. Locations of post construction control practices
2. List of hazardous materials and other chemicals.

TABLE I. LIST OF SITE POLLUTANTS		
CATEGORY	PRODUCT	POLLUTANTS

## E. BEST MANAGEMENT PRACTICES (BMP)

### 1. Erosion Control

Erosion control, also referred to as soil stabilization, consists of source control measures that are designed to prevent soil particles from detaching and becoming transported in storm water runoff. Erosion control BMPs protect the soil surface by covering and/or binding soil particles. This construction project will implement the following practices to provide effective temporary and final erosion control during construction. This includes Wind Erosion controls.

### 2. Sediment Controls

Sediment controls are temporary or permanent structural measures that are intended to complement the selected erosion control measures and reduce sediment discharges from active construction areas. Sediment controls are designed to

## ATTACHMENT G2 ESCAPE TEMPLATE ONLY

intercept and settle out soil particles that have been detached and transported by the force of water. This includes track out controls such as stabilized entrance and roadways.

### 3. Non-Storm water Controls

All construction equipment utilized on-site shall be regularly inspected for leaks and repaired immediately. Petroleum distillate fueled and lubricated equipment shall be properly maintained to prevent leakage of such materials. Servicing of such equipment shall be performed in such a manner that all petroleum distillate materials do not come into contact with the ground and shall be disposed of properly offsite.

### 4. Materials Management and Waste Management

Materials management control practices consist of implementing procedural and structural BMPs for handling, storing and using construction materials to prevent the release of those materials into storm water discharges. The amount and type of construction materials to be utilized at the Site will depend upon the type of construction and the length of the construction period. The materials may be used continuously, such as fuel for vehicles and equipment, or the materials may be used for a discrete period, such as soil binders for temporary stabilization.

## F. NON-STORM WATER MANAGEMENT

Non-storm water management at this site involves prevention of contamination from the following sources:

- Vehicle fluids, including oil, grease, petroleum, and coolants;
- Vehicle equipment and wash water;
- Asphaltic emulsions associated with asphalt-concrete paving operations;
- Chemical curing compounds and cure water from concrete curing;
- Concrete washout water;
- Water and solid waste from concrete finishing;
- Paints, solvents, thinners, acids;
- Accumulated sediment from dewatering operations;
- Portable toilet waste;
- General litter.

## G. ACCIDENTAL DISCHARGES

Accidental discharges can be the greatest cause of pollution of the storm water discharges. All emergency spill controls and measures shall be performed as follows:

1. Notify the Resident Inspector immediately

## ATTACHMENT G2 ESCAPE TEMPLATE ONLY

2. Contain the spread of spills
3. If the spills occur on paved or impermeable surfaces, clean them up using “dry” methods (absorbent materials, cat litter, and/or rags). Contain the spills by encircling with absorbent materials and do not let them spread widely.

### **H. POST CONSTRUCTION STORM WATER MANAGEMENT**

Post construction storm water management will be the same as the existing pre-construction storm water management practices.

### **I. WASTE MANAGEMENT AND DISPOSAL**

All wastes including waste oil and other equipment wastes shall be disposed of off-site in compliance with federal, state and local regulations. Proper disposal of construction related wastes and equipment wastes is the responsibility of the contractor. Contractor is required to submit detailed information regarding waste management and disposal.

### **J. MAINTENANCE, INSPECTION, REPORTS, AND REPAIR**

Contractor is responsible for implementation of the ESCAPE. VTA will ensure compliance with permit requirements and contract specifications.

While many of the storm pollution control measures are actually structural controls which, to function properly, require ongoing inspection, maintenance and repair. Once a week site inspections, daily monitoring, Inspections before and after a storm event are required. The results of the inspection and assessment must be written and include the date of inspection, the person who performed the inspection, and the observations. A tracking or follow-up procedure must follow any inspection, which discovers deficiencies in the BMP's. Copies of inspection reports will be forwarded to VTA.

Based on the annual inspection, a Certificate of Compliance is required to be filed. Contractor will annually certify, to VTA, that the construction operations (both Contractor's activity and construction activity) are in compliance with the requirements of this ESCAPE.

### **K. RECORD KEEPING AND REPORTS**

Contractor is responsible for implementation of the ESCAPE. VTA will ensure compliance with permit requirements and contract specifications. All amendments will be submitted to VTA for approval prior to incorporation.

During the course of construction, unanticipated changes may occur, such as schedule changes, phasing changes, and staging area modifications. These changes must be made known and the ESCAPE revised accordingly. Revisions to the ESCAPE are also required when the properly installed BMP system is ineffective. All revisions will be submitted to VTA for approval prior to incorporation.



## **ATTACHMENT G2 ESCAPE TEMPLATE ONLY**

Non-compliance must be reported to the Regional Water Quality Control Board. This notification is to identify the types of non-compliance, the actions required to come into compliance, and a time schedule to achieve compliance.

All monitoring of this ESCAPE will be submitted to and recorded by VTA. All records will be maintained for three (3) years after completion of the construction activity

**ATTACHMENT A**

**SITE SPECIFIC MAP/PLANS & DETAILS**

1. Site Plan:

List the plan sheet(s) that show the project site and scope of construction activity. Site plan sheets need to conform to VTA's requirements (e.g., size, scale) for site plan submitted for Grading and Construction Permits. The site plan and project description in the Project Description section of the ESCAPE need to match.

2. BMP Locations:

List the plan sheet(s) that show the locations of proposed construction activity BMPs. Some BMPs may be included as notes on the site plan. In addition to BMPs, show required local creek setbacks and preserved existing vegetation on the site plan.

3. BMP Implementation Schedule:

Identify schedule for BMP implementation with the commencement of the construction activities and that BMPs will be implemented year round, as appropriate, until the project is complete. Include final site stabilization in the schedule..

**ATTACHMENT B**

**PROJECT COMPLIANCE PERMITS AND  
SPECIFICATIONS**

# ATTACHMENT G2 ESCAPE TEMPLATE ONLY

## ATTACHMENT C

### APPLICABLE CASQA BEST MANAGEMENT PRACTICES (BMPs)

#### ENCLOSED CASQA BMPS

1. Erosion Control
  - a. EC-
  - b. EC-
2. Sediment Control
  - a. SE-
  - b. SE-
3. Non-Storm water Control
  - a. NS-
  - b. NS-
4. Tracking Control
  - a. TC-
  - b. TC-
5. Wind Erosion Control
  - a. WE-
  - b. WE-
6. Waste/Material Management
  - a. WM-
  - b. WM-



## **APPENDIX I PRE-QUALIFICATION REQUIREMENTS**

Refer to Contract **Section 1.9 Pre-Qualification Requirements** as an introduction to this Appendix I.

**Request for Pre-Qualification of Bidders** is provided in the following pages.

*[This Page Intentionally Left Blank]*



Contract No. C19123

# Request for Pre-qualification of Bidders

Cerone Division Boiler &  
Propane Tank Replacement

Issued  
November 5, 2019

*[This page intentionally left blank]*

---

**TABLE OF CONTENTS**

NOTICE..... 3

    A. SOLICITATION OF PRE-QUALIFICATION STATEMENTS..... 3

    B. OBTAINING THE REQUEST FOR PRE-QUALIFICATION ..... 3

    C. SUBMITTAL LOCATION AND DEADLINE..... 3

    D. INQUIRIES..... 4

    E. NOTICE OF DETERMINATION..... 4

    F. BID SOLICITATION PERIOD..... 4

    G. VALIDATION OF PRIOR PRE-QUALIFICATION ..... 4

INTRODUCTION TO THE REQUEST FOR PRE-QUALIFICATION..... 5

    A. PROJECT BACKGROUND ..... 5

    B. PROJECT DESCRIPTION ..... 5

    C. PROCUREMENT PROCESS: PREQUALIFICATION PROCUREMENT ..... 6

    D. PROJECT SCHEDULE ..... 6

    E. PREPARATION OF THE SOQ SUBMITTAL ..... 6

    F. EVALUATION AND ANALYSIS ..... 6

    G. NOTICE OF APPEAL ..... 6

    H. GENERAL CONTRACTOR AND ENGINEERING FIRMS..... 7

    I. CONFIDENTIALITY ..... 7

    J. RESERVATION OF RIGHTS OF VTA ..... 7

PRE-QUALIFICATION QUESTIONNAIRE ..... 9

PART I: CONTACT INFORMATION ..... 11

    A. BIDDER’S CONTACT INFORMATION ..... 11

    B. EXECUTION AND CERTIFICATION ..... 11

PART II. ESSENTIAL REQUIREMENTS FOR QUALIFICATION ..... 13

PART III. ORGANIZATION HISTORY, ORGANIZATIONAL PERFORMANCE, COMPLIANCE WITH CIVIL AND  
CRIMINAL LAWS ..... 15

PART IV. RECENT CONSTRUCTION PROJECTS COMPLETED ..... 27

ATTACHMENT 1 - STATEMENT OF QUALIFICATION CERTIFICATION FORM ..... 29

ATTACHMENT 2 - VALIDATION STATEMENT ..... 31

APPENDIX A: PROJECT SITE MAP..... 33

APPENDIX B: SCORING MATRIX..... 39

APPENDIX C: INTERVIEW QUESTIONNAIRE ..... 45

**NOTES:**

- ATTACHMENT 1**      **Statement of Qualification Certification Form**  
Bidder is required to turn this form in along with the Pre-Qualification Questionnaire.
- ATTACHMENT 2**      **Validation Statement**  
As described in Item G. "Validation of Prior Pre-Qualification" herein, Bidders who have previously been pre-qualified by VTA may submit this form instead of the Pre-Qualification Questionnaire.
- APPENDIX A:**      **Project Site Map**  
Appendix A does not require any action by the Bidder. The project site map is included for Bidder's information only.
- APPENDIX B:**      **Scoring Matrix**  
Appendix B does not require any action by the Bidder. The scoring matrix is included for Bidder's information only.
- APPENDIX C:**      **Interview Questionnaire**  
Appendix C does not require any action by the Bidder. Appendix C contains only questions used by VTA staff to interview owner references. This is included for Bidder's information only.

## **NOTICE**

### **A. SOLICITATION OF PRE-QUALIFICATION STATEMENTS**

The Santa Clara Valley Transportation Authority (VTA) will be soliciting bids for the Cerone Division Boiler & Propane Tank Replacement Project (Project).

Notice is hereby given that VTA is now soliciting Statements of Qualifications (SOQ) from bidders (Bidders) with construction expertise in heating hot water boilers, and propane fuel storage & distribution systems. This Request for Pre-Qualification of Bidders is intended to solicit information in the form of a Pre-Qualification Questionnaire and qualification statements.

All Bidders that intend to submit a bid for the Project must fully complete the Pre-Qualification Questionnaire, provide all materials requested herein, and be approved by VTA in order to be included on the final qualified Bidders list. No bid will be accepted from a Bidder that has failed to comply with these requirements. If two or more contractors submit a SOQ as part of a Joint Venture or expect to submit a SOQ as part of a Joint Venture, each entity within the Joint Venture must be separately pre-qualified.

Answers to questions contained in the attached Pre-Qualification Questionnaire, information about current bonding capacity, notarized statement from surety, and the most recent reviewed or audited financial statements, with accompanying notes and supplemental information, are required. VTA will use these documents as the basis of rating contractors in respect to the Project size and scope. VTA reserves the right to check other sources available. VTA's decision will be based on objective evaluation criteria.

### **B. OBTAINING THE REQUEST FOR PRE-QUALIFICATION**

View all solicitations advertised by VTA at <https://www.vta.org/solicitations>. Click on the name of the solicitation that you are interested in.

To download documents for a solicitation, click "**Register or Log In to Download**" if you're not logged in, and once you are registered and logged in, click "**Become a Plan Holder**" in order to download the documents. There is no charge for downloading these documents.

Register as a vendor and sign up for notifications for your North American Industry Classification System ("NAICS") business codes at <https://www.vta.org/user/register?type=vendor>. By registering as a VTA vendor, Bidders will automatically receive notifications by email of upcoming VTA bidding opportunities. It is highly recommended that prospective Bidders acquire the Request for Pre-Qualification documents directly from the VTA website in order to be assured of obtaining all addenda. The Request for Pre-Qualification documents will also be included the Invitation for Bids (IFB) issued for this Project.

### **C. SUBMITTAL LOCATION AND DEADLINE**

Bidders seeking to participate in this Request for Pre-Qualification process must submit a fully completed SOQ in a sealed package marked "CONFIDENTIAL" to:

**Santa Clara Valley Transportation Authority  
Procurement, Contracts and Materials Management  
3331 North First Street, Building A  
San José, CA 95134-1906  
ATTENTION: Kiet Vu / Pre-Qualification for Contract C19123**

Bidders may submit pre-qualification packages during regular working hours on any day that the offices of VTA are open. The SOQ package must be submitted on or before the bid opening date as detailed in the IFB.

Potential Bidders that are not pre-qualified may qualify during the solicitation period. Contractors not currently pre-qualified, and intending to be pre-qualified, must request pre-qualification sufficiently in advance of the closing date for bids so as to ensure there will be no need to extend the solicitation period or delay the award.

Failure to provide a responsive SOQ by the time specified above will preclude the Bidder from subsequent participation in the IFB for the Project.

**D. INQUIRIES**

Inquiries regarding this Request for Pre-Qualification must be directed by e-mail to Kiet Vu at Kiet.Vu@vta.org.

**E. NOTICE OF DETERMINATION**

VTA will notify each Bidder that submits a SOQ regarding their qualification status by letter no later than ten business days after submission of the pre-qualification package. If a Bidder submits its pre-qualification on the bid opening date, VTA will not issue the Notice of Recommended Award until all pre-qualification packages have been reviewed.

**F. BID SOLICITATION PERIOD**

Bidders may be pre-qualified as defined in Section E above. Please note the following:

Bidders are encouraged to submit pre-qualification packages as soon as possible, so that they may be notified of omissions of information to be remedied or of their pre-qualification status well in advance of the bid opening date for this Project.

The closing time for bids will not be changed in order to accommodate supplementation of incomplete submissions, or late submissions.

**G. VALIDATION OF PRIOR PRE-QUALIFICATION**

Bidders who have been pre-qualified by VTA will be considered pre-qualified for a project of similar size and scope for one year following the date of notification of pre-qualification. The Validation Statement (Attachment 2) is required to be submitted on the date stated for pre-qualification packages.

## **INTRODUCTION TO THE REQUEST FOR PRE-QUALIFICATION**

### **A. PROJECT BACKGROUND**

VTA's Cerone Division Heating Hot Water (HHW) heating system, installed in the 1970s, consists of a 30,000-gallon liquid propane tank, gas vaporization equipment, and boilers located at the Central Energy Building (Building F). The boilers provide the heat source for an underground HHW piping system which circulates in a loop from Building F to Buildings B, E, & G. The 30,000-gallon liquid propane tank and vaporizers are past their useful life and require replacement. The existing boilers and two of the four vaporizers have broken down and are beyond repair.

A temporary boiler plant has been installed as an interim solution to provide heat to Buildings B, E and G, but is undersized for the Cerone Division's needs. In addition, the underground HHW and propane piping systems have deteriorated, resulting in unreliable heating performance. Numerous leaks have shut down the systems intermittently, and the system is exhibiting excessive heat loss, resulting in poor performance and excessive energy consumption. This Project will decommission the old systems and construct new HHW & propane systems that have been redesigned for greater efficiency and reliability.

### **B. PROJECT DESCRIPTION**

The Project will consist of furnishing all labor, materials, tools, equipment, services, supervision, and incidentals necessary to replace the HHW boiler system and the propane gas storage and distribution system at VTA's Cerone Division bus operations and maintenance facility located at 3990 Zanker Rd., San Jose. The Contract will construct (i) two new propane fired boiler plants, (ii) install new above and below ground HHW piping, (iii) connect to existing HHW systems, and (iv) test and commission the new HHW systems. The Contract will also (i) install a new propane storage and distribution system consisting of a 30,000-gallon Liquefied Petroleum Gas (LPG) storage tank, (ii) fill station, (iii) LPG vaporizers, (iv) all associated piping, valves, safety equipment, connection to existing propane pipe networks, and (v) testing and commissioning of the propane storage and delivery system.

The Project includes related controls and monitoring systems, constructing bollards and concrete support structures, and all related civil, electrical, and plumbing work. The Project will decommission, demolish, and dispose of the existing propane storage tank and system, including related fill port, piping and vaporizers. The Project will also demolish and dispose of the existing central boiler plant and related HHW facilities and equipment inside Building F.

The Project will also:

- i. Construct joint utility trenches through existing paved and landscaped areas, protect trenches from vehicular and pedestrian traffic during construction, and restore paved and landscaped areas.
- ii. Modify existing plumbing (propane, HHW, industrial cold water, sanitary sewer) for connection of (and in support of) the new HHW and propane systems.
- iii. Modify and expand electrical infrastructure in support of new HHW and propane systems.

The estimated cost of construction for the Project is in the range of \$1,500,000 to \$2,300,000.

### **C. PROJECT DELIVERY**

The selected Bidder will be the single point of contact and have contractual responsibility for all services contracted by VTA for the Project.



**D. PROCUREMENT PROCESS: PREQUALIFICATION PROCUREMENT**

The process for award of this Project includes this Request for Pre-Qualification and the issuance of the IFB to pre-qualified firms.

Only those firms that have been found to be qualified in the pre-qualification process may submit sealed bids with pricing information.

Award is then made to the lowest responsive and responsible Bidder as though it were a regular sealed-bid procurement.

Prior to submitting a SOQ in response to this Request for Pre-qualification, Bidders are advised to carefully review Section B (PROJECT DESCRIPTION) in order to understand the requirements of this Project.

**E. PROJECT SCHEDULE**

It is anticipated that the IFB will be advertised in **January 2020** with bid opening **February 2020** (Solicitation Period). The estimated time for construction of the Project is 300 calendar days.

**F. PREPARATION OF THE SOQ SUBMITTAL**

Each prospective Bidder must provide a complete, responsive SOQ package which consists of contact information and general information, essential requirements for qualification, scored questions, and project experience, with all the required attachments and any other supplemental information. Submission of an incomplete and/or unclear SOQ could result in a determination by VTA that the prospective Bidder is nonresponsive and therefore not pre-qualified.

Bidders must submit one (1) original copy of the SOQ package to be delivered to VTA at the required location and time specified in **Item C, Submittal Location and Deadline, of the NOTICE** section above.

Each questionnaire must be signed under penalty of perjury in the manner designated on the form provided as **Attachment 1 - Statement of Qualification Certification Form**, by an individual who has the legal authority to bind the Bidder on whose behalf that person is signing. If any information provided by a Bidder becomes inaccurate, the Bidder must immediately notify VTA and provide updated accurate information in writing, under penalty of perjury.

**G. EVALUATION AND ANALYSIS**

All SOQs will first be reviewed for their responsiveness, including timely receipt of the package and inclusion of all required forms. Any SOQ that is incomplete in any material respect may be deemed non-responsive and maybe rejected in its entirety.

**Note:** A contractor may be found not pre-qualified for bidding on this specific Project until the contractor meets VTA's requirements. In addition, a contractor may be found not pre-qualified for either:

- (1) Omission of requested information or
- (2) Falsification of information

Bidders will be scored based on the Request for Pre-Qualification Questionnaire Score Sheet (see APPENDIX B: Scoring Matrix).

**H. NOTICE OF APPEAL**

A Bidder can make an appeal in regard to its pre-qualification rating. The Bidder initiates the appeal by delivering a notice of appeal to VTA no later than ten business days prior to the closing time for the receipt of bids (refer to Item C under the NOTICE section above titled "Submittal Location and Deadline"). Without a

timely appeal, the Bidder waives any and all rights to challenge the decision of VTA, whether by administrative process, judicial process or any other legal process or proceeding.

If the Bidder requests a hearing on its appeal, the hearing process will be conducted and will conclude no later than five business days after VTA's receipt of the notice of appeal, and no later than five business days prior to the closing time for the receipt of bids. The hearing will be an informal process conducted by a panel to whom VTA's Board of Directors has delegated responsibility to hear such appeals (the "Appeals Panel"). At or prior to the hearing, the Bidder will be advised of the basis for VTA's pre-qualification determination. The Bidder will be given the opportunity to present information and reasons in opposition to the rating. Within one day after the conclusion of the hearing, the Appeals Panel will render its decision. It is the intention of VTA that the date for the submission and opening of bids will not be delayed or postponed to allow for completion of an appeal process.

#### **I. GENERAL CONTRACTOR AND ENGINEERING FIRMS**

Bidders are advised that they must have a California contractor's license, classification **Class A (General Engineering), or Class B (General Building)** to bid on this Project. All of Contractor's subcontractors must also be properly licensed to perform the work for which they are responsible.

The Request for Pre-Qualification requires the Bidder to identify and supply information regarding the General Contractor. All Bidders responding to this Request for Pre-Qualification are hereby cautioned that the Contractor's State License Law regulates contractor licensing matters. Each Bidder, in its pre-qualification submittals must disclose all of its license classifications, numbers, and expiration dates.

Bidders are also advised that Contractor and all subcontractors used for the Project must be registered, pursuant to Section 1725.5 of the California Labor Code, with the Department of Industrial Relations ("DIR") at the time of bid opening. This Project is subject to compliance monitoring and enforcement by the DIR.

#### **J. CONFIDENTIALITY**

The pre-qualification packages (answers submitted on the Pre-Qualification Questionnaire) submitted by Bidders are not public records and are not open to public inspection. All information provided will be kept confidential to the extent permitted by law. However, the contents may be disclosed to third parties for purpose of verification, or investigation of substantial allegations, or in the appeal hearing. State law requires that the names of contractors applying for pre-qualification status will become public records subject to disclosure, and the first page of the Pre-Qualification Questionnaire will be used for that purpose.

#### **K. RESERVATION OF RIGHTS OF VTA**

VTA reserves, holds and may exercise, at its sole discretion, the following rights and conditions with regard to this Request for Pre-qualification, and by responding to this Request for Pre-Qualification, Bidder acknowledges and consents to the following rights and conditions:

1. VTA reserves the right to adjust, increase, limit, suspend or rescind the pre-qualification rating based on gathered information.
2. VTA reserves the right to waive minor irregularities and omissions in the information contained in the submitted Request for Pre-Qualification application.

While it is the intent of the Pre-Qualification Questionnaire and documents to assist VTA in determining Bidder responsibility prior to bid and to aid VTA in selecting the lowest responsive and responsible Bidder, neither the fact of pre-qualification, nor any pre-qualification rating, will preclude VTA from a post-bid

consideration and determination of whether a Bidder has the quality, fitness, capacity and experience to satisfactorily perform the proposed work, and has demonstrated the requisite trustworthiness.



# PRE-QUALIFICATION QUESTIONNAIRE

## CERONE DIVISION BOILER & PROPANE TANK REPLACEMENT CONTRACT No. C19123

**SUBMITTAL LOCATION:** Santa Clara Valley Transportation Authority  
Procurement, Contracts and Materials Management  
3331 North First Street, Building A  
San José, CA 95134-1906  
**ATTENTION:** Kiet Vu / Pre-Qualification for Contract C19123

**BIDDER:** \_\_\_\_\_  
*(provide name of firm)*

**DATE:** \_\_\_\_\_

**Note:** Only this cover page, Parts I through IV of this document (along with any requested or required supporting documents), and Attachment 1 - Statement of Qualification Certification Form are to be submitted.

*[This page intentionally left blank]*

**PART I: CONTACT INFORMATION**

The Bidder must provide all of the following contact information to be considered for further review. The Bidder is the contractor that will execute the Project contract.

**A. BIDDER'S CONTACT INFORMATION**

1. Firm Name: \_\_\_\_\_  
*(as it appears on license)*
  
2. Address: \_\_\_\_\_
  
3. Phone Number of Firm: \_\_\_\_\_ Fax: \_\_\_\_\_
  
4. Contact Person & Title: \_\_\_\_\_  
*(contact person for this SOQ; contact does not need to be the firm's owner)*
  
5. Contact Person Email: \_\_\_\_\_
  
6. Bidder is:       a Corporation                       a Partnership  
                          a Sole Proprietorship               a Joint Venture  
                          Other legal entity (specify): \_\_\_\_\_
  
7. Date of company formation or incorporation: \_\_\_\_\_
  
8. Under the laws of what state: \_\_\_\_\_

**B. EXECUTION AND CERTIFICATION**

Complete and attach **ATTACHMENT 1 - STATEMENT OF QUALIFICATION CERTIFICATION FORM**. All Information set forth in this SOQ will be certified under penalty of perjury by the Bidder and, if a partnership or joint venture, its general partners or joint venture members.

**- END OF PART I -**

*[This page intentionally left blank]*

## PART II. ESSENTIAL REQUIREMENTS FOR QUALIFICATION

**Contractor will be immediately disqualified if the answer to any of questions 1 through 5 is "No."<sup>1</sup>**

1. Contractor possesses a valid and current California Contractor's license for this Project for which it intends to submit a bid.  
 Yes       No
2. Contractor has a liability insurance policy with a policy limit of at least \$1,000,000 per occurrence and \$2,000,000 aggregate.  
 Yes       No
3. Contractor has current workers' compensation insurance policy as required by the Labor Code or is legally self-insured pursuant to Labor Code section 3700 et. seq.  
 Yes       No       Contractor is exempt from this requirement, because it has no employees
4. Have you attached your latest copy of a reviewed or audited financial statement with accompanying notes and supplemental information?  
 Yes       No

**NOTE: A financial statement that is not either reviewed or audited is not acceptable. A letter verifying availability of a line of credit may also be attached; however, it will be considered as supplemental information only, and is not a substitute for the required financial statement.**

5. Have you attached a notarized statement from an admitted surety insurer (approved by the California Department of Insurance) and authorized to issue bonds in the State of California, which states: (a) that your current bonding capacity is sufficient for the project for which you seek pre-qualification if you are seeking pre-qualification for a single project; or (if you are seeking pre-qualification valid for a year) (b) your current available bonding capacity?<sup>2</sup>  
 Yes       No

**NOTE: Notarized statement must be from the surety company, not an agent or broker.**

---

<sup>1</sup> A "No" answer to Question 4 will not be disqualifying if the contractor is exempt from complying with Question 4, for reasons explained in footnote 2.

<sup>2</sup> An additional notarized statement from the surety may be requested by VTA at the time of submission of a bid, if this pre-qualification package is submitted more than 60 days prior to submission of the bid.



6. Has your contractor's license been revoked at any time in the last five years?
- Yes       No
7. Has a surety firm completed a contract on your behalf, or paid for completion because your firm was default terminated by the project owner within the last five (5) years?
- Yes       No
8. At the time of submitting this pre-qualification form, is your firm ineligible to bid on or be awarded a public works contract, or perform as a subcontractor on a public works contract, pursuant to either Labor Code section 1777.1 or Labor Code section 1777.7?
- Yes       No

If the answer is "Yes," state the beginning and ending dates of the period of debarment:

\_\_\_\_\_

9. At any time during the last five years, has your firm, or any of its owners or officers been convicted of a crime involving the awarding of a contract of a government construction project, or the bidding or performance of a government contract?
- Yes       No

**- End of Part II -**

**PART III. ORGANIZATION HISTORY, ORGANIZATIONAL PERFORMANCE,  
COMPLIANCE WITH CIVIL AND CRIMINAL LAWS**

**Current Organization and Structure of the Business**

**For Firms That Are Corporations:**

- 1a. Date incorporated: \_\_\_\_\_
- 1b. Under the laws of what state: \_\_\_\_\_
- 1c. Provide all the following information for each person who is either (a) an officer of the corporation (president, vice president, secretary, treasurer), or (b) the owner of at least ten per cent of the corporation's stock.

Name	Position	Years with Co.	% Ownership
	CEO		
	President		
	Secretary		
	Treasurer		

- 1d. Identify every construction firm that any person listed above has been associated with (as owner, general partner, limited partner or officer) at any time during the last five years.

**NOTE: For this question, "owner" and "partner" refer to ownership of ten per cent or more of the business, or 10 per cent or more of its stock, if the business is a corporation.**

Person's Name	Construction Firm	Dates of Person's Participation with Firm

**For Firms That Are Partnerships:**

- 1a. Date of formation: \_\_\_\_\_
- 1b. Under the laws of what state: \_\_\_\_\_

1c. Provide all the following information for each partner who owns 10 per cent or more of the firm. *(attach additional pages if necessary)*

Name	Position	Years with Co.	% Ownership

1d. Identify every construction company that any partner has been associated with (as owner, general partner, limited partner or officer) at any time during the last five years.

**NOTE: For this question, “owner” and “partner” refer to ownership of ten per cent or more of the business, or ten per cent or more of its stock, if the business is a corporation.**

Person’s Name	Construction Company	Dates of Person’s Participation with Company

**For Firms That Are Sole Proprietorships:**

- 1a. Date of commencement of business. \_\_\_\_\_
- 1b. Social security number of company owner. \_\_\_\_\_
- 1c. Identify every construction firm that the business owner has been associated with (as owner, general partner, limited partner or officer) at any time during the last five years.

**NOTE: For this question, “owner” and “partner” refer to ownership of ten per cent or more of the business, or ten per cent or more of its stock, if the business is a corporation.**

Person’s Name	Construction Company	Dates of Person’s Participation with Company

**For Firms That Intend to Make a Bid as Part of a Joint Venture:**

- 1a. Date of commencement of joint venture. \_\_\_\_\_
- 1b. Provide all of the following information for each firm that is a member of the joint venture that expects to bid on one or more projects:

Name of firm	% Ownership of Joint Venture

**History of the Business and Organizational Performance:**

2. Has there been any change in ownership of the firm at any time during the last three years?

**NOTE: A corporation whose shares are publicly traded is not required to answer this question.**

Yes       No

If "yes," explain on a separate signed page.

3. Is the firm a subsidiary, parent, holding company or affiliate of another construction firm?

**NOTE: Include information about other firms if one firm owns 50 per cent or more of another, or if an owner, partner, or officer of your firm holds a similar position in another firm.**

Yes       No

If "yes," explain on a separate signed page.

4. Are any corporate officers, partners or owners connected to any other construction firms?

**NOTE: Include information about other firms if an owner, partner, or officer of your firm holds a similar position in another firm.**

Yes       No

If "yes," explain on a separate signed page.

5. State your firm's gross revenues for each of the last three years:

2016: \$ \_\_\_\_\_

2017: \$ \_\_\_\_\_

2018: \$ \_\_\_\_\_

**Scored Questions:**

6. How many years has your organization been in business in California as a contractor under your present business name and license number? \_\_\_\_\_ Years

7. Is your firm currently the debtor in a bankruptcy case?

Yes       No

If "yes," please attach a copy of the bankruptcy petition, showing the case number, and the date on which the petition was filed.

8. Was your firm in bankruptcy at any time during the last five years? (This question refers only to a bankruptcy action that was not described in answer to question 7, above)

Yes       No

If "yes," please attach a copy of the bankruptcy petition, showing the case number and the date on which the petition was filed, and a copy of the Bankruptcy Court's discharge order, or of any other document that ended the case, if no discharge order was issued.

**Licenses:**

9. List all California construction license numbers, classifications and expiration dates of the California contractor licenses held by your firm:

License Number	Trade Classification	Date Issued	Expiration Date

10. If any of your firm's license(s) are held in the name of a corporation or partnership, list below the names of the qualifying individual(s) listed on the California State Licensing Board (CSLB) records who meet(s) the experience and examination requirements for each license.

\_\_\_\_\_  
\_\_\_\_\_

11. Has your firm changed names or license number in the past five years?

Yes       No

If "yes," explain on a separate signed page, including the reason for the change.

12. Has any owner, partner or (for corporations) officer of your firm operated a construction firm under any other name in the last five years?

Yes       No

If "yes," explain on a separate signed page, including the reason for the change.

13. Has any CSLB license held by your firm or its Responsible Managing Employee (RME) or Responsible Managing Officer (RMO) been suspended within the last five years?

Yes       No

If "yes," explain on a separate signed page.

**Disputes:**

14. At any time in the last five years has your firm been assessed and paid liquidated damages after completion of a project under a construction contract with either a public or private owner?

Yes       No

If yes, explain on a separate signed page, identifying all such projects by owner, owner's address, the date of completion of the project, amount of liquidated damages assessed and all other information necessary to fully explain the assessment of liquidated damages.

15. In the last five years has your firm, or any firm with which any of your company's owners, officers or partners was associated, been debarred, disqualified, removed or otherwise prevented from bidding on, or completing, any government agency or public works project for any reason?

**NOTE: "Associated with" refers to another construction firm in which an owner, partner or officer of your firm held a similar position, and which is listed in response to Part II question 1c or 1d on this form.**

Yes       No

If “yes,” explain on a separate signed page. State whether the firm involved was the firm applying for pre-qualification here or another firm. Identify the name of the company, the name of the person within your firm who was associated with that company, the year of the event, the owner of the project, the project and the basis for the action.

16. In the last five years has your firm been denied an award of a public works contract based on a finding by a public agency that your company was not a responsible bidder?

Yes       No

If “yes,” explain on a separate signed page. Identify the year of the event, the owner, the project and the basis for the finding by the public agency.

\* \* \* \* \*

**NOTE: The following two (2) questions, refer only to disputes between your firm and the owner of a project. You need not include information about disputes between your firm and a supplier, another contractor, or subcontractor. You need not include information about “pass-through” disputes in which the actual dispute is between a sub-contractor and a project owner. Also, you may omit reference to all disputes with amounts of less than \$50,000.**

17. In the past five years has any claim **against** your firm concerning your firm’s work on a construction project been **filed in court or arbitration?**

Yes       No

If “yes,” on separate signed page identify the claim(s) and provide the project name, date of the claim, name of claimant, a brief description of the nature of the claim, the court in which the case was filed and a brief description of the status of the claim (pending or, if resolved, a brief description of the resolution).

18. In the past five years has your firm made any claim against a project owner concerning work on a project or payment for a contract and **filed that claim in court or arbitration?**

Yes       No

If “yes,” on separate signed page identify the claim and provide the project name, date of the claim, name of the entity (or entities) against whom the claim was filed, a brief description of the nature of the claim, the court in which the case was filed and a brief description of the status of the claim (pending, or if resolved, a brief description of the resolution).

\* \* \* \* \*

19. At any time during the past five years, has any surety company made any payments on your firm's behalf as a result of a default, to satisfy any claims made against a performance or payment bond issued on your firm's behalf, in connection with a construction project, either public or private?

Yes       No

If "Yes," explain on a separate signed page the amount of each such claim, the name and telephone number of the claimant, the date of the claim, the grounds for the claim, the present status of the claim, the date of resolution of such claim if resolved, the method by which such was resolved, the nature of the resolution and the amount, if any, at which the claim was resolved.

20. In the last five years has any insurance carrier, for any form of insurance, refused to renew the insurance policy for your firm?

Yes       No

If "Yes," explain on a separate signed page. Name the insurance carrier, the form of insurance and the year of the refusal.

**Criminal Matters and Related Civil Suits:**

21. Has your firm or any of its owners, officers or partners ever been found liable in a civil suit or found guilty in a criminal action for making any false claim or material misrepresentation to any public agency or entity?

Yes       No

If "Yes," explain on a separate signed page, identifying who was involved, name of the public agency, date of the investigation and the grounds for the finding.

22. Has your firm or any of its owners, officers or partners ever been convicted of a crime involving any federal, state, or local law related to construction?

Yes       No

If "Yes," explain on a separate signed page, identifying who was involved, name of the public agency, date of the conviction and the grounds for the conviction.

23. Has your firm or any of its owners, officers or partners ever been convicted of a federal or state crime of fraud, theft, or any other act of dishonesty?

Yes       No



If "Yes," identify on a separate signed page the person or persons convicted, the court (the county if a state court, the district or location of the federal court), the year and the criminal conduct.

**Bonding:**

24. Bonding Capacity: Provide documentation from your surety identifying the following:

Name of bonding company/surety: \_\_\_\_\_

Name of surety agent, address and telephone number:

\_\_\_\_\_  
\_\_\_\_\_

25. If your firm was required to pay a premium of more than one per cent for a performance and payment bond on any project(s) on which your firm worked at any time during the last three years, state the percentage that your firm was required to pay. You may provide an explanation for a percentage rate higher than one per cent, if you wish to do so.

\_\_\_\_\_  
\_\_\_\_\_

26. List all other sureties (name and full address) that have written bonds for your firm during the last five years, including the dates during which each wrote the bonds:

\_\_\_\_\_  
\_\_\_\_\_  
\_\_\_\_\_

27. During the last five years, has your firm ever been denied bond coverage by a surety company, or has there ever been a period of time when your firm had no surety bond in place during a public construction project when one was required?

Yes       No

If yes, provide details on a separate signed sheet indicating the date when your firm was denied coverage and the name of the company or companies which denied coverage; and the period during which you had no surety bond in place.

**Compliance with Occupational Safety and Health Laws and with Other Labor Legislation Safety**

28. Has CAL OSHA cited and assessed penalties against your firm for any “serious,” “willful” or “repeat” violations of its safety or health regulations in the past five years?

**NOTE: If you have filed an appeal of a citation, and the Occupational Safety and Health Appeals Board has not yet ruled on your appeal, you need not include the information about the citation.**

Yes       No

If “Yes,” attached a separate signed page describing the citations, including information about the dates of the citations, the nature of the violation, the project on which the citation(s) was or were issued, the amount of penalty paid, if any. If the citation was appealed to the Occupational Safety and Health Appeals Board and a decision has been issued, state the case number and the date of the decision.

29. Has the Federal Occupational Safety and Health Administration cited and assessed penalties against your firm in the past five years?

**NOTE: If you have filed an appeal of a citation and the Appeals Board has not yet ruled on your appeal, or if there is a court appeal pending, you need not include information about the citation.**

Yes       No

If “Yes,” attach a separate signed page describing each citation.

30. Has the EPA or any Air Quality Management District or any Regional Water Quality Control Board cited and assessed penalties against either your firm or the owner of a project on which your firm was the contractor, in the past five years?

**NOTE: If you have filed an appeal of a citation and the Appeals Board has not yet ruled on your appeal, or if there is a court appeal pending, you need not include information about the citation.**

Yes       No

If “Yes,” attach a separate signed page describing each citation.

31. How often do you require documented safety meetings to be held for construction employees and field supervisors during the course of a project?

Once each week or more often

Less than once each week

32. List your firm's Experience Modification Rate (EMR) (California workers' compensation insurance) for each of the past three premium years:

**NOTE: An Experience Modification Rate is issued to your firm annually by your workers' compensation insurance carrier.**

	Year	List EMR
Most recent available year		
Previous year		
Year prior to previous year		
Three-year average EMR:		

If your EMR for any of these three years is or was 1.00 or higher, attach a letter of explanation.

33. Within the last five years has there ever been a period when your firm had employees but was without workers' compensation insurance or state-approved self-insurance?

Yes       No

If "Yes," please explain the reason for the absence of workers' compensation insurance on a separate signed page. If "No," please provide a statement by your current workers' compensation insurance carrier that verifies periods of workers' compensation insurance coverage for the last five years. (If your firm has been in the construction business for less than five years, provide a statement by your workers' compensation insurance carrier verifying continuous workers' compensation insurance coverage for the period that your firm has been in the construction business.)

**Prevailing Wage and Apprenticeship Compliance Record:**

34. Has there been more than one occasion during the last five years in which your firm was required to pay either back wages or penalties for your own firm's failure to comply with the **State's** prevailing wage laws?

**NOTE: This question refers only to your own firm's violation of prevailing wage laws, not to violations of the prevailing wage laws by a subcontractor.**

Yes       No

If "Yes," attach a separate signed page or pages, describing the nature of each violation, identifying the name of the project, the date of its completion, the public agency for which it was constructed; the number of employees who were initially underpaid and the amount of back wages and penalties that you were required to pay.

35. During the last five years, has there been more than one occasion in which your own firm has been penalized or required to pay back wages for failure to comply with the **Federal Davis-Bacon** prevailing wage requirements?

Yes       No

If "Yes," attach a separate signed page or pages describing the nature of the violation, identifying the name of the project, the date of its completion, the public agency for which it was constructed; the number of employees who were initially underpaid, the amount of back wages you were required to pay along with the amount of any penalty paid.

36. Provide the **name, address and telephone number** of the apprenticeship program (approved by the California Apprenticeship Council) from whom you intend to request the dispatch of apprentices to your company for use on any public work project for which you are awarded a contract by VTA.

Name: \_\_\_\_\_

Address: \_\_\_\_\_

Telephone: \_\_\_\_\_

37. If your firm operates its own State-approved apprenticeship program, **provide the following information on a separate page and insert in this Part III.**
- a. Identify the craft or crafts in which your firm provided apprenticeship training in the past year.
  - b. State the year in which each such apprenticeship program was approved, and attach evidence of the most recent California Apprenticeship Council approval(s) of your apprenticeship program(s).
  - c. State the number of individuals who were employed by your firm as apprentices at any time during the past three years in each apprenticeship and the number of persons who, during the past three years, completed apprenticeships in each craft while employed by your firm.

38. At any time during the last five years, has your firm been found to have violated any provision of California apprenticeship laws or regulations, or the laws pertaining to use of apprentices on public works?

**NOTE: You may omit reference to any incident that occurred prior to January 1, 1998, if the violation was by a subcontractor and your firm, as general contractor on a project, had no knowledge of the subcontractor's violation at the time they occurred.**

Yes       No

If "Yes," provide the date(s) of such findings, and attach copies of the Department's final decision(s).

**Not Scored - For Information Only:**

39. The following is required for information only and will not be used as prequalification criteria.

In the past five years, has a governmental agency claimed that your firm violated any law, rule or regulation including the laws of any country, state or locality?

Yes       No

In the latter situation, indicate whether your firm has been required to pay a penalty or fine equal to greater than \$10,000 or required to take remedial action costing \$10,000 or more, or whether members of the firm have been subject to periods of incarceration of 30 days or more.

- **End of Part III** -

#### **PART IV. RECENT CONSTRUCTION PROJECTS COMPLETED**

Contractor shall provide information about its six most recently completed public works projects and its three largest completed private projects within the last three years.<sup>3</sup> Names and references must be current and verifiable.

**Use separate sheets of paper for each project. Use the form on the next page or substitute a similar form that has the same order of requested information.**

---

<sup>3</sup> If you wish, you may, using the same format, also provide information about other projects that you have completed that are similar to the project(s) for which you expect to bid.

**PROJECT DATA SHEET # \_\_\_\_**  
(One data sheet per project; number each sheet)

**NAME OF BIDDER:** \_\_\_\_\_

Project Name: _____	
Project Location: _____	
Owner	
Owner Contact Name	
Owner Contact Phone No.	
Owner Contact Email	
Architect or Engineer (A/E)	
A/E Contact Name	
A/E Contact Phone No.	
A/E Contact Email	
Construction Manager Name	
Construction Manager Phone No.	
Construction Manager Email	
Description of Project and Scope of Work Performed	
Total Value of Construction (including change orders)	
Original Scheduled Completion Date	
Time Extensions Granted (number of days)	
Actual Date of Completion	

- End of Part IV -

**ATTACHMENT 1 - STATEMENT OF QUALIFICATION CERTIFICATION FORM**

**CERTIFICATION:**

The undersigned is/are a legally authorized representative(s) of the Entity, and hereby declare that I am/ we are submitting this Request for Pre-Qualifications; I am/we are duly authorized to sign this Request for Pre-Qualifications on behalf of the above named firm; and I/we have read all the answers herein and know all of their contents and that all information set forth in this Request for Pre-Qualifications and all attachments hereto are, to the best of my/our knowledge, true, accurate and complete as of its submission date.

The undersigned certifies and declares under penalty of perjury under the laws of the State of California, that the foregoing is true and correct and that this declaration was executed in

\_\_\_\_\_ County, California, on \_\_\_\_\_.

(Date)

Signature: \_\_\_\_\_ Date: \_\_\_\_\_

BIDDER's Typed Name and Title:

\_\_\_\_\_  
\_\_\_\_\_



*[This page intentionally left blank]*

**ATTACHMENT 2 - VALIDATION STATEMENT**

Applicant Firm: \_\_\_\_\_

Tax ID No. or SSN \_\_\_\_\_



**PRIME CONTRACTOR PRE-QUALIFICATION VALIDATION STATEMENT**

A copy of this VALIDATION FORM must be completed and signed by at least one General Partner, Owner, Principal or Officer Authorized to Legally Commit the Applicant Firm. Submit to VTA on or before the date specified for Pre-Qualification Packages are due.

**NOT TO BE SUBMITTED WITH APPLICATION – FOR VALIDATION ONLY**

**RFP or IFB Name and Number** \_\_\_\_\_

**DECLARATION**

I, (printed full name) \_\_\_\_\_ hereby declare under penalty of perjury under the laws of the United States of America and of the State of California that I am the (position or title) \_\_\_\_\_ of (firm name) \_\_\_\_\_, and that I am duly authorized to execute this Validation Statement on behalf of this entity. I acknowledge that any false, deceptive or fraudulent statements on this Validation Statement will result in denial of pre-qualification. I hereby certify and declare that:

The Pre-Qualification Application dated \_\_\_\_\_ on file with VTA is correct and current as submitted.

-OR-

The Pre-Qualification Application dated \_\_\_\_\_ on file with VTA is correct and current as submitted, except as modified by the attached changed pages and/or attachments to said application. (Applicants may attach additional sheets to describe changes). Attach recent financial statements if previous are more than one year old.

Date: \_\_\_/\_\_\_/\_\_\_

\_\_\_\_\_  
**Signature of Person Certifying for Applicant Firm**

A MATERIAL FALSE STATEMENT, OMISSION OR FRAUDULENT INDUCEMENT MADE IN CONNECTION WITH THIS PRE-QUALIFICATION IS SUFFICIENT CAUSE FOR DENIAL OF THE APPLICATION OR REVOCATION OF A PRIOR APPROVAL, THEREBY PRECLUDING THE APPLICANT FIRM FROM DOING BUSINESS WITH, OR PERFORMING WORK FOR VTA, EITHER AS A PRIME CONTRACTOR, SUBCONTRACTOR OR SUPPLIER FOR A PERIOD OF THREE YEARS. IN ADDITION, SUCH FALSE SUBMISSION MAY SUBJECT THE PERSON AND/OR ENTITY MAKING THE FALSE STATEMENT TO CRIMINAL CHARGES. [TITLE 18 USC 1001, FALSE STATEMENTS; CALIFORNIA PENAL CODE SECTION 132, OFFERING ALTERED OR ANTE-DATED OR FORGED DOCUMENTS OR RECORDS; AND SECTION 134, PREPARING FALSE DOCUMENTARY EVIDENCE.]

*[This page intentionally left blank]*

**APPENDIX A: PROJECT SITE MAP**

*[This page intentionally left blank]*

# Santa Clara Valley Transportation Authority Cerone Division Boiler & Propane Tank Replacement Contract C19123

## Site Map

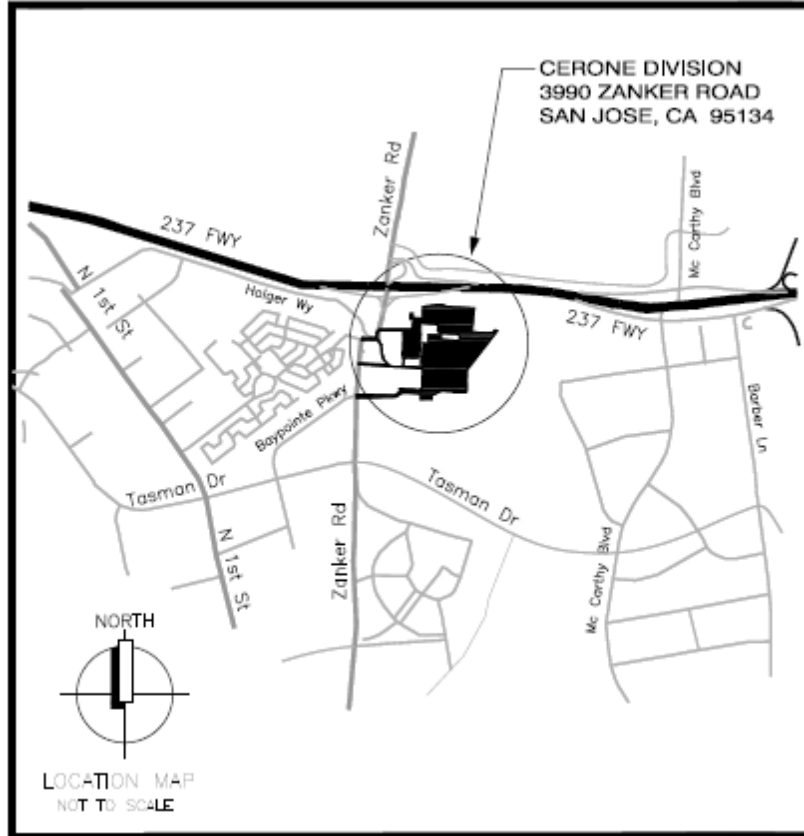

*[This page intentionally left blank]*

# Santa Clara Valley Transportation Authority Cerone Division Boiler & Propane Tank Replacement Contract C19123

## Area of Work

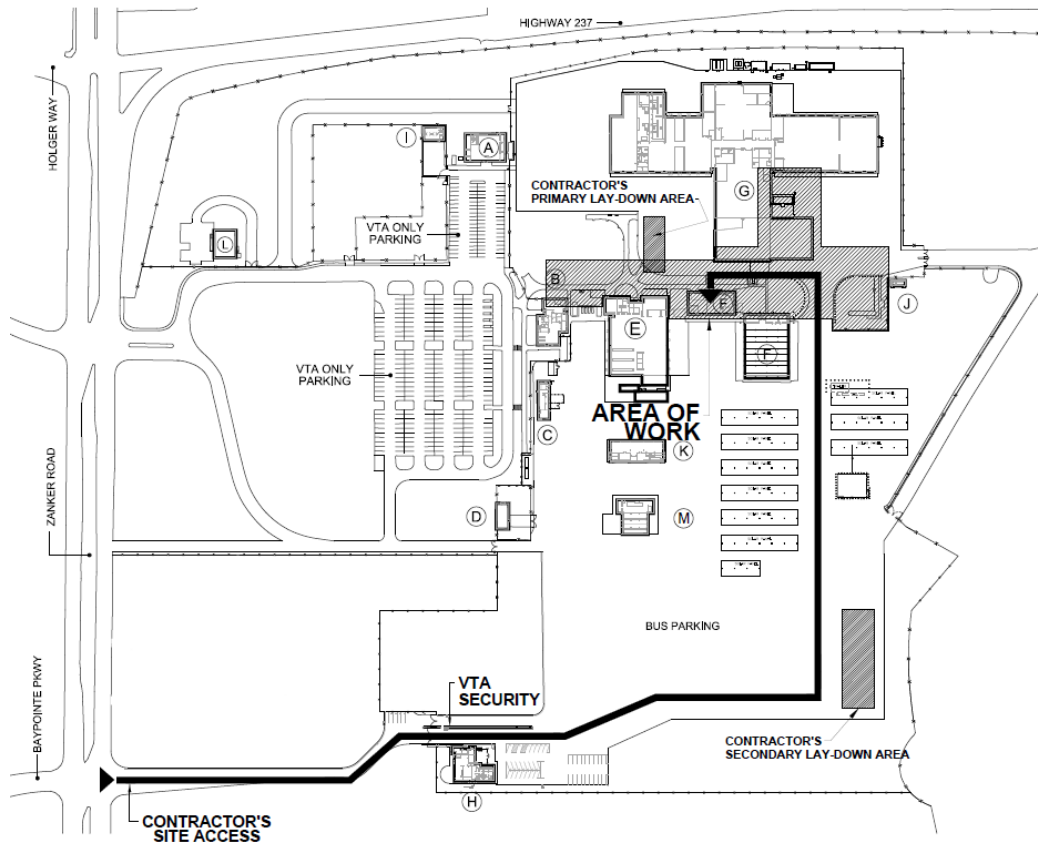



*[This page intentionally left blank]*

## **APPENDIX B: SCORING MATRIX**

*Note: References to Part I, Part II, Part III and Part IV refer to the Parts of the Pre-Qualification Questionnaire.*

### **A. PART I: CONTACT INFORMATION**

Part I seeks information about the makeup of the BIDDER, and is for identification purposes only. There is no evaluative scoring value for these parts.

### **B. PART II: ESSENTIAL REQUIREMENTS FOR QUALIFICATION**

This part seeks information about the BIDDER, and consists of pass/fail questions. This is the first step in rating the BIDDER. A Bidder that “fails” any one of the questions 1-9 listed in Part II will be disqualified (except with respect to certain questions providing additional requirements for consideration).

### **C. PART III: ORGANIZATION, HISTORY, ORGANIZATIONAL PERFORMANCE, COMPLIANCE WITH CIVIL AND CRIMINAL LAWS**

The first set of questions (Questions 1 to 5) seek information about the organization and structure of the BIDDER. There is no evaluative scoring value for these questions.

The next sets of questions (Questions 6 to 38) are scored. Refer to the Scoring Matrix on the next page.

### **D. PART IV:**

This part seeks information about the Bidders project experience and requests contact information for each project.

Interviews will be conducted based on this information and scored. Refer to APPENDIX C: INTERVIEW QUESTIONNAIRE for the set of questions and passing score.

To prequalify, the Bidder must have a passing grade within each of the two sections identified below.

CERONE DIVISION BOILER & PROPANE TANK REPLACEMENT  
Contract C19123

QUESTION #	QUANTITY	YES	NO	SCORE
6	6 yrs + = 5 pts 5 yrs = 4 pts 4 yrs = 3 pts 3 yrs or less = 2 pts	N/A	N/A	
7	N/A	0	3	
8	N/A	0	3	
Questions 9 to 12 are not scored				
13	N/A	0	5	
14	5 pts for 0 project with \$50,000 + LDs <u>or</u> 1 project with LD 3 pts for 2 projects with \$50,000 + LD 0 pt for any other answer	N/A	N/A	
15	N/A	0	5	
16	N/A	0	5	
17	If firm's average gross revenue for the last 3 years was < \$50M: 5 pts for "No" or "Yes" with 1 instance 3 pts for "Yes" with 2 instances 0 pts for "Yes" with more than 2 instances  If firm's average gross revenue for the last 3 years was > \$50M: 5 pts for "No" or "Yes" with 1, 2, or 3 instances 3 pts for "Yes" with 4 or 5 instances 0 pts for "Yes" with more than 5 instances	N/A	N/A	
18	If firm's average gross revenue for the last 3 years was < \$50M: 5 pts for "No" or "Yes" with 1 instance 3 pts for "Yes" with 2 instances 0 pts for "Yes" with more than 2 instances  If firm's average gross revenue for the last 3 years was > \$50M: 5 pts for "No" or "Yes" with 1, 2, or 3 instances 3 pts for "Yes" with 4 or 5 instances 0 pts for "Yes" with more than 5 instances	N/A	N/A	
19	5 pts for "No" or "Yes" with 1 claim 3 pts for 2 claims -5 pts for more than 2 claims	N/A	N/A	
20	5 pts for "No" or "Yes" with 1 instance	N/A	N/A	

CERONE DIVISION BOILER & PROPANE TANK REPLACEMENT  
Contract C19123

QUESTION #	QUANTITY	YES	NO	SCORE
	3 pts for 2 instances 0 pt for more than 2 instances			
21	N/A	-5	5	
22	N/A	-5	5	
23	N/A	-5	5	
Questions 24 and 26 are not scored				
25	5 pts for rate ≤ 1% 3 pts for rate no higher than 1.10% 0 pts for any other answer	N/A	N/A	
27	N/A	0	5	

<b>TOTAL SCORE – QUESTIONS 6 TO 27</b>	
<input type="checkbox"/>	<b>Pass (scored 57 to 76)</b>
<input type="checkbox"/>	<b>Disqualified - total score is less than 57</b>

CERONE DIVISION BOILER & PROPANE TANK REPLACEMENT  
Contract C19123

QUESTION #	QUANTITY	YES	NO	SCORE
28	<p>If firm's average gross revenue for the last 3 years was &lt; \$50M: 5 pts for "No" or "Yes" with 1 instance 3 pts for "Yes" with 2 instances 0 pts for "Yes" with more than 2 instances</p> <p>If firm's average gross revenue for the last 3 years was &gt; \$50M: 5 pts for "No" or "Yes" with 1, 2, or 3 instances 3 pts for "Yes" with 4 or 5 instances 0 pts for "Yes" with more than 5 instances</p>	N/A	N/A	
29	<p>If firm's average gross revenue for the last 3 years was &lt; \$50M: 5 pts for "No" or "Yes" with 1 instance 3 pts for "Yes" with 2 instances 0 pts for "Yes" with more than 2 instances</p> <p>(continuance of Question 29)</p> <p>If firm's average gross revenue for the last 3 years was &gt; \$50M: 5 pts for "No" or "Yes" with 1, 2, or 3 instances 3 pts for "Yes" with 4 or 5 instances 0 pts for "Yes" with more than 5 instances</p>	N/A	N/A	
30	<p>If firm's average gross revenue for the last 3 years was &lt; \$50M: 5 pts for "No" or "Yes" with 1 instance 3 pts for "Yes" with 2 instances 0 pts for "Yes" with more than 2 instances</p> <p>If firm's average gross revenue for the last 3 years was &gt; \$50M: 5 pts for "No" or "Yes" with 1, 2, or 3 instances 3 pts for "Yes" with 4 or 5 instances 0 pts for "Yes" with more than 5 instances</p>	N/A	N/A	
31	<p>3 pts for once a week or more often 0 pts for any other answer</p>	N/A	N/A	
32	<p>5 pts for 3- year average EMR of <math>\leq 0.95</math> 3 pts for 3- year average EMR of 0.95 to 1.00</p>	N/A	N/A	

CERONE DIVISION BOILER & PROPANE TANK REPLACEMENT  
Contract C19123

QUESTION #	QUANTITY	YES	NO	SCORE
	0 pts for any other EMR			
33	5 pts for "No" or "Yes" with 1 instance 0 pts for any other answer	N/A	N/A	
34	If firm's average gross revenue for the last 3 years was < \$50M: 5 pts for "No" or "Yes" with 1 or 2 instances 3 pts for "Yes" with 3 instances 0 pts for "Yes" with more than 3 instances  If firm's average gross revenue for the last 3 years was > \$50M: 5 pts for "No" or "Yes" with ≤ 4 instances 3 pts for "Yes" with 5 or 6 instances 0 pts for "Yes" with more than 6 instances	N/A	N/A	
35	If firm's average gross revenue for the last 3 years was < \$50M: 5 pts for "No" or "Yes" with 1 or 2 instances 3 pts for "Yes" with 3 instances 0 pts for "Yes" with more than 3 instances  If firm's average gross revenue for the last 3 years was > \$50M: 5 pts for "No" or "Yes" with ≤ 4 instances 3 pts for "Yes" with 5 or 6 instances 0 pts for "Yes" with more than 6 instances	N/A	N/A	
36	5 pts for 1 or more approved apprenticeship program is listed. 0 pts for any other answer	N/A	N/A	
37	5 pts for 1 or more persons completed an approved apprenticeship program while employed by the firm. 0 pts for no person completed an approved apprenticeship program	N/A	N/A	
38	If firm's average gross revenue for the last 3 years was < \$50M: 5 pts for "No" or "Yes" with 1 or 2 instances 3 pts for "Yes" with 3 instances 0 pts for "Yes" with more than 3 instances	N/A	N/A	

QUESTION #	QUANTITY	YES	NO	SCORE
------------	----------	-----	----	-------

If firm's average gross revenue for the last 3 years was > \$50M:  
5 pts for "No" or "Yes" with ≤ 4 instances  
3 pts for "Yes" with 5 or 6 instances  
0 pts for "Yes" with more than 6 instances

TOTAL SCORE – QUESTIONS 28 TO 38
<input type="checkbox"/> Pass (scored 38 to maximum 53)
<input type="checkbox"/> Disqualified - total score is less than 38

### APPENDIX C: INTERVIEW QUESTIONNAIRE

The highest possible score is 120 Points. A score less than 55 points disqualifies a contractor from bidding on this project. For a score of between 56 and 72, conduct an interview of another contact, that is, a manager of another completed project. A score of 72 or higher on each of two interviews is sufficient for pre-qualification.

**Company to be Pre-Qualified** : \_\_\_\_\_  
**VTA Project to be Pre-Qualified for** : \_\_\_\_\_  
**Company to be Interviewed** : \_\_\_\_\_  
**Company Contact Person** : \_\_\_\_\_  
**Contact Person's Phone Number** : \_\_\_\_\_  
**Contact Person's Email Address** : \_\_\_\_\_  
**Referenced Project** : \_\_\_\_\_

NUMBER	QUESTION	SCORE
1.	On a scale of 1-10, with 10 being the best, did the contractor provide adequate personnel?	Score: _____
2.	On a scale of 1-10, with 10 being the best, did the contractor provide adequate supervision?	Score: _____
3.	On a scale of 1-10, with 10 being the best, was there adequate equipment provided on the job?	Score: _____
4.	On a scale of 1-10, with 10 being the best, was the contractor timely in providing reports and other paperwork, including change order paperwork and scheduling updates?	Score: _____
5.	On a scale of 1-10, with 10 being the best, did the contractor adhere to the project schedule that your [agency] [business] approved?	Score: _____
6.	On a scale of 1 to 10, with 10 being the best, was the project completed by the contractor on schedule? (10 = completed on schedule including approved time extensions, 1 = significant and harmful delays)	Score: _____
7.	On a scale of 1-10, with 10 being the best, rate the contractor on the timely submission of reasonable cost and time estimates to perform change order work.	Score: _____
8.	On a scale of 1-10, with 10 being the best, rate the contractor on how well the contractor performed the work after a change	Score: _____



CERONE DIVISION BOILER & PROPANE TANK REPLACEMENT  
Contract C19123

NUMBER	QUESTION	SCORE
	order was issued, and how well the contractor integrated the change order work into the existing work.	
9.	On a scale of 1-10, with 10 being the best, rate how has the contractor been performing in the area of turning in Operation & Maintenance manuals, completing as-built drawings, providing required training and punch list items?	Score: _____
10.	On a scale of 1-10, Has the contractor made any claim, dispute or lawsuit in excess of \$50,000 concerning work or payment? (10 = no claims > \$50K, 5 = 1 claim, 0 = many claims).	Score: _____
11.	On a scale of 1-10, with 10 being the highest, rate the contractor with respect to timely payments by the contractor to either subcontractors or suppliers. (If the person being interviewed knows of no such difficulties, the score on this question should be "10.")	Score: _____
12.	On a scale of 1-10, with 10 being the best, how would you rate the quality of the work overall?	Score: _____
13.	Are there any outstanding stop notices, liens, or claims by the contractor that are currently unresolved on contracts for which notices of completion were recorded more than 120 days ago? (1 point for each is deducted from overall score; maximum amount to be deducted is 5 points)	# of stop notices, liens or claims: _____

PRE-QUALIFICATION INTERVIEW RESULT				
SECTION	POSSIBLE SCORE	PASSING SCORE	EARNED SCORE	RESULT
<b>Question No. 1 to Question No. 12</b>	<b>120</b>	<b>55</b>	_____	
<b>Deduction as per Question No. 13</b>	<b>0</b>	<b>0</b>	_____	
<b>Total</b>	<b>120</b>	<b>55</b>	_____	<input type="checkbox"/> Passed <input type="checkbox"/> Failed

Interviewer: \_\_\_\_\_

Signature: \_\_\_\_\_

Date: \_\_\_\_\_

## **APPENDIX M**

# **QUALITY ASSURANCE AND QUALITY CONTROL REQUIREMENTS**

The Contractor shall at his own expense, within 10 calendar days following the Notice of Award, prepare and submit to VTA for approval a Quality Control Plan. The contractor shall establish, implement, and maintain the quality control plan to manage, control, document, and ensure that materials and Work complies with the requirements of the contract documents. The minimum contractor quality control activities are defined in the construction contract.

The contractor's quality control plan should address the following elements:

- Managing the work to ensure that both onsite and offsite work complies with the contract requirements, including the work of subcontractors, suppliers, and testing laboratories.
- Managing submittals, including but not limited to, supplemental quality control plans, qualification and certification documents for laboratories and testing personnel, certificates of compliance, shop drawings and proposed methods for fabrication and construction activities, mix designs, inspection reports, and test results.
- Providing the necessary inspection to ensure effective quality control and assurance of quality for acceptance of materials and workmanship. This includes but is not limited to fabrication, sampling and testing, production, storage, delivery, construction, and placement.
- Identifying, controlling, and documenting materials and workmanship that do not meet the specified level of quality. Documentation should include the nature of the non-conformance, location, extent, and disposition (such as removed and replaced, reworked, accepted based on engineering judgment). The final disposition of non-conforming materials or workmanship must be authorized by Caltrans.
- Training to ensure that proficiency is achieved and maintained by personnel performing activities that affect quality.
- Ensuring that the equipment used in the production and testing of the materials provides accurate and precise measurements in accordance with the applicable specifications.
- Maintaining a record of inspections, including but not limited to, date of inspection, results of inspection, and any subsequent corrective actions taken.

*[This Page Intentionally Left Blank]*

## APPENDIX N PERMIT APPLICATIONS

Bay Area Air Quality Management District (BAAQMD)

- **Form P-101B – Authority to Construct / Permit to Operate**
- **Instruction P-101B – Application Instructions**
- **Form P – Emission Point**
- **Form HRA – Health Risk Assessment**

For additional guidance, Contractor is directed to the following resources on the BAAQMD website:

- BAAQMD Permit Handbook: <http://www.baaqmd.gov/permits/permitting-manuals>
- BAAQMD Current Fee Schedule: <http://www.baaqmd.gov/rules-and-compliance/current-rules/regulation-3-2019-archive>

County of Santa Clara Hazardous Materials Compliance Division (HMCD)

1. **HMCD-004 – Plan Submittal Requirements for Hazardous Materials Systems**
2. **HMCD-017 – Aboveground Tank Closure Guidelines**
3. **HMCD-018 – Aboveground Tank Closure Permit Application & Plan**
4. **HMCD-024A – Equipment List for Aboveground Storage Tank Systems**
5. **HMCD-028 – Hazardous Materials Clearance Form**
6. **HMCD-111 – Guidelines for On-Site Cleaning of Hazardous Materials Storage Tank Systems**
7. **HMCD-112 – Hazardous Materials Storage System – Cleaning / Cutting Plan**
8. **HMCD-116 – Hazardous Materials Construction Permit**
9. **HMCD-UN-020 – Hazardous Materials Business Plan**

For additional guidance, Contractor is directed to the following HMCD resources:

- HMCD Website: <https://www.sccgov.org/sites/hazmat/Pages/hmp.aspx>
- HMCD Current Fee Schedule: <https://www.sccgov.org/sites/hazmat/fees/Pages/home.aspx>

CA Department of Industrial Relations – Division of Occupational Safety & health – Pressure Vessel Unit

1. **Pressure Vessel Permit to Operate Application**

*[This Page Intentionally Left Blank]*

**APPENDIX O**  
**HAZARDOUS MATERIAL SURVEY REPORT**

**2018 BURNS & MCDONNELL**  
**NON-DESTRUCTIVE**  
**HAZARDOUS MATERIAL SURVEY REPORT**

*[This Page Intentionally Left Blank]*



November 5, 2018

Dan Pornel  
Senior Environmental Engineer  
Santa Clara Valley Transportation Authority  
1436 California Circle  
Milpitas, CA 95035

Re: Updated-Limited Non-Destructive Hazardous Material Survey - Cerrone Bus Yard

Dear Dan:

On behalf of the Santa Clara Valley Transportation Authority (SCVTA), Burns & McDonnell Engineering Company, Inc., (Burns & McDonnell) is pleased to present the results of the additional hazardous material survey sampling performed on September 19, 2018. Further, this *Updated-Limited Non-Destructive Hazardous Material Survey- Cerrone Bus Yard* (Report) presents the combined results of the August 9, and September 19, 2018 sampling events at the SCVTA Cerrone Bus Yard, Building F (Site), located at 3990 Zanker Road, San Jose, CA. The Site location is shown on Figure 1.

Under contract to Burns & McDonnell, SCA Environmental, Inc., (SCA) performed additional hazardous materials sampling within Bldg. F at the request of SCVTA on September 19, 2018. SCA collected and analyzed samples from collected from the gray concrete housekeeping pads (boilers, diesel generators, electrical cabinet), and caulking above expansion joints on the perimeter of the concrete housekeeping pads.

The additional hazardous materials survey was undertaken to determine the presence/non-presence of potentially hazardous materials; lead, asbestos, and polychlorinated biphenyls (PCBs) containing materials for the future decommissioning, demolition, and disposal of:

- Decommissioned boilers associated concrete housekeeping pads,
- Backup diesel generators associated concrete housekeeping pads, and expansion joint caulking on the perimeter of the concrete pads.
- Electrical equipment cabinet associated concrete housekeeping pad.

#### **NON-DESTRUCTIVE SAMPLING ACTIVITIES**

Hazardous materials sampling was performed by a SCA Certified Industrial Hygienist (CIH), Certified Asbestos Consultant (CAC), Certified Safety Professional (CSP), and California



Dan Pornei  
Santa Clara Valley Transportation Authority  
November 5, 2018  
Page 2

Department of Public Health (CDPH) professional on August 9, 2018<sup>1</sup> and September 19, 2018. August and September 2018 sampling locations are documented in Appendix A of the SCA Report dated October 26, 2018: Figure 1 depicts interior sample locations, Figure 2 depicts exterior sample locations. Site and field sampling photographs are presented as Appendix B.

### **Hazardous Materials Findings-SCA Updated Report November 2, 2018**

#### **Asbestos Containing Materials**

Asbestos Containing Materials (ACM) were confirmed in the gray caulking present on the perimeters of the gray concrete housekeeping pads.

- ACMs present in the gray caulking at 3%.

#### **Polychlorinated Biphenyls**

PCB Containing Materials (PCM) were identified in the gray caulking present on the perimeters of the gray concrete housekeeping pads.

- PCMs present in the gray caulking at 0.28 mg/kg.

#### **Non-Asbestos Containing Materials**

Non-asbestos Containing materials (NACM): additional samples of the gray concrete housekeeping pads (boilers, electrical equipment, and generators) were analyzed for the presence of ACM.

- ACMs were not detected in the concrete samples: NACM <1%.

### **SUMMARY: HAZARDOUS MATERIALS SURVEY**

The hazardous materials surveys conducted at the SCVTA Cerrone Bus Yard confirmed the presence of ACMs, lead, and PCBs in the subject materials (e.g.: boilers, generators, piping, caulking) of this survey. Lead, ACM, and PCBS containing materials are tabulated in the SCA Report-Table 1: Materials Matrix Report (MMR) Updated November 2, 2018 Report (Appendix A).

#### **Asbestos Containing Materials**

A summary of the August 9, 2018 and September 19, 2018 surveys identified ACMs, Assumed Asbestos Containing Materials (AACM), and NACMs is provided below:

---

<sup>1</sup> Limited Non-Destructive Hazardous Material Survey- Cerrone Bus Yard. Burns & McDonnell Engineering Company, Inc. September 10, 2018.

Dan Pernel  
Santa Clara Valley Transportation Authority  
November 5, 2018  
Page 3

- Ten (10) tested materials with ACM >1%.
- ACM samples CONC-2-1 and CONC-2-2 (collected on the diesel generator pads) are likely particulate dust contaminated with asbestos fibers that collected on the surface of the concrete pads and are only visible through a microscope.
- All housekeeping concrete pads (boiler, electrical, and generator) are negative for asbestos fiber (non-detect).
- Three (3) inaccessible materials are AACM and will require additional “destructive testing” once the location is vacated. These materials are designated AAA in Appendix A Table 1 (Nov. 2, 2018).
- Nineteen (19) NACM suspect materials were tested or visually determined to be NACM.

#### **Lead Containing Materials**

Lead containing materials (LCM) as paint were confirmed present and assumed present (structural steel coating). These LCM are detailed in Appendix A Table 1 (Nov. 2, 2018) and summarized below:

- LCM in paint confirmed at concentrations ranging from 226 milligrams per kilogram (mg/kg) to 12,292 mg/kg.
- LCM as structural steel coating are assumed present at >1,000 mg/kg.

#### **Polychlorinated Biphenyls**

PCMs were identified in association with the generator dampers (Appendix A Table 1 (Nov. 2, 2018)) and assumed present in mercury containing light ballasts and lighting fixtures. PCMs are tabulated in Table 1 and summarized below:

- PCMs present on the corrugated galbestos panels ranging from < laboratory detection limit to 11 mg/kg.
- PCMs present on the gray joint caulking around the perimeter of gray concrete equipment pads at 0.28 mg/kg.
- Ballasts associated with lighting fixtures are assumed to contain >50 mg/kg PCBs.



Dan Pernel  
Santa Clara Valley Transportation Authority  
November 5, 2018  
Page 4

**Conclusions & Recommendations**

The August 9, 2018 and September 19, 2018 Hazardous Materials Sampling events confirmed the presence of lead, ACM, and PCB containing materials on the Site features surveyed by SCA. Sampling locations are depicted Figure 1 and Figure 2 (Appendix A), updated sampling results are documented in the November 2, 2018 Table 1 (Appendix A), and certified analytical reports are provided in Appendix B of the SCA Report.

Potential bidders must properly address the particulate dust contaminated with asbestos fiber on the diesel generator housekeeping concrete pads prior to the demolition of these concrete pads. Appropriate corrective actions should be conducted after both emergency generator units have been removed to prevent hazardous particulate dust from becoming airborne during demolition.

Burns & McDonnell concurs with SCA that the results and recommendations of this survey will be presented to potential demolition contractors, and that the recommendations presented within the SCA Report are to be adhered.

Sincerely,

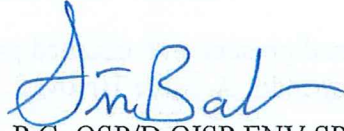

Simon Barber, P.G. QSP/D QISP ENV SP  
Senior Geologist



Attachments:

Figure 1: Site Location

Appendix A: SCA Environmental, Inc.- Limited Non-Destructive Hazardous materials  
Sampling: Santa Clara Valley Transportation Authority (VTA) Cerone Bus Yard-  
August 31, 2018.

SCA Environmental, Inc.- Limited Non-Destructive Hazardous materials  
Sampling: Santa Clara Valley Transportation Authority (VTA) Cerone Bus Yard-  
Updated November 2, 2018

Appendix B: Site Photographs

cc: Jorge Mares- SCVTA  
Karmjot Singh - SCVTA  
John O'Brien - SCVTA  
Chris D'Sa- Burns & McDonnell

**FIGURE 1- SITE LOCATION**



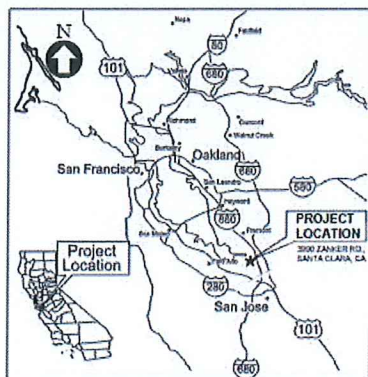

SOURCE:

KEY MAP



FACILITY:  
 Cerrone Bus Yard  
 SCVTA: Building F- Hazardous Material  
 Survey & Sampling

SCVTA Cerrone Bus Yard  
 Site Location  
 3990 Zanker Road  
 San Jose, California

PROJECT: 87119  
 FILE NAME:

FIGURE 1

**APPENDIX A -SCA ENVIRONMENTAL, INC., LIMITED NON-DESTRUCTIVE HAZARDOUS  
MATERIALS SAMPLING-SANTA CLARA VALLEY TRANSPORTATION  
AUTHORITY (VTA) CERONE BUS YARD,  
UPDATED NOVEMBER 2, 2018.**





ENVIRONMENTAL, INC.

Updated November 2, 2018

Mr. Simon Barber, PG  
Burns & McDonnell  
400 Oyster Point Blvd., Ste 533  
South San Francisco, CA 94080  
email: sbarber@burnsmcd.com

RE: Limited Non-Destructive Hazardous Materials Sampling  
Santa Clara Valley Transportation Authority (VTA) Cerone Bus Yard  
3990 Zanker Road, San Jose, CA 95134  
SCA Project No: F-12766

Dear Mr. Barber:

This report summarizes the results of a limited non-destructive hazardous materials investigation of the boilers and generators in Building F at the Santa Clara VTA Cerone Bus Yard, located in San Jose, CA. The Santa Clara VTA Cerone Bus Yard is in the process of upgrading some mechanical equipment, specifically:

- Removal of the decommissioned boilers (2)
- Removal of water pumps (2) and associated pipes and flues
- Decommissioning and removal of the diesel generators (2)
- Removal of dampers (3) and associated flues

SCA was tasked with non-destructive asbestos, lead, and polychlorinated biphenyls (PCBs) sampling. Sampling was conducted on August 9, 2018 and September 19, 2018 by Dan Leung, CIH, CSP, CAC, CDPH. SCA also conducted visual identification of suspect PCB lighting ballasts and mercury-containing lighting tubes.

The following sections summarize the results of the sampling.

### Asbestos

Sampling activities were conducted per Federal AHERA regulations (40 CFR Part 763). Samples of suspect materials were collected following modified AHERA sampling protocols, and sample locations were documented on field diagrams (Attachment A). Under these procedures, the first sample is analyzed. If it tests positive for asbestos (>1%), the analysis is suspended for further samples of that material. If the first sample tests only trace positive (between 0.1 to 1%), or negative, however, the second and/or third samples are analyzed sequentially, in order to determine the possible presence of asbestos. If all samples test negative, the material is considered as non-asbestos. If one or more samples test "trace" positive (<1%), the material is considered to be trace positive. Certain non-homogenous materials, multiple samples would be gathered at various points in the location, with all samples analyzed to determine the possible presence of asbestos.

All asbestos samples collected by SCA were submitted to Reservoirs Environmental, Inc. (REI Labs) for analysis by polarized light microscopy with dispersion staining (DS/PLM). REI is a NVLAP-accredited facility.

SCA has entered the sampling data into **Table 1: Material Matrix Report (MMR)** which shows detailed sample results, locations, and quantity estimates. Materials designated as AAA are assumed to contain asbestos and require destructive testing to confirm asbestos content or should be treated as asbestos containing. Sample locations are included on the sample location diagrams in **Attachment A** and Laboratory results in **Attachment B**. Note the following:

1. The MMR (**Table 1**) lists positive, assumed and negative materials, the locations where each material is present, and the quantity estimates in each location. Any suspect material not sampled (or not verified visually as negative) is listed as assumed (AAA) in the MMR.
2. Asbestos-Containing Materials: A total of nine (9) materials were identified as Asbestos-containing materials (>1%). These materials are summarized in Table 1.
3. Assumed Asbestos-Containing Materials: Three (3) materials were not accessible during the survey. These materials are assumed asbestos-containing and designated "AAA" in Table 1. Assumed asbestos-containing items will require additional "destructive testing" once the location is vacated.
4. Non-asbestos Materials – Nineteen (19) suspect materials were tested or visually determined to be non-asbestos. All non-asbestos containing materials are tabulated in **Table 1: Materials Matrix Report**.

SCA assumes that this survey report may be referenced by Abatement Contractors providing bids for abatement of materials prior to demolition at the surveyed site. SCA requests that this text portion of the report be provided to bidding contractors for review. Bidding Contractors are hereby notified that the quantities included herein are estimates only, and all quantities should be field verified by the Contractor for any budgeting, planning or bidding decisions.

### Lead

SCA performed bulk lead sampling of representative coatings on the boilers and generators to confirm the presence and extent of lead content in paints. Samples were analyzed by Reservoirs Environmental in Denver, CO by ICP/MS methodology.

The MMR (**Table 1**) shows detailed lead sample results and locations of the sampled materials. Sample locations are included on the sample location diagrams in **Attachment A** and laboratory reports in **Attachment C**. The following summarizes the results:

1. Results of paints ranged from 226 milligrams per kilogram (mg/kg) to 12,929 mg/kg.
2. Coatings on structural steel were not all sampled, but are assumed to contain >1000 mg/kg lead.

None of the applicable regulations require removal of lead paint prior to demolition if the paints are securely adhered to the substrates (i.e., non-flaking or non-peeling). Disposal of the demolition debris in this case can be handled as non-hazardous and non-RCRA waste after the loose and flaking paint have been removed, as long as demolition practices do not compromise worker safety and waste stream characterization testing has been performed by the Contractor on the entire waste stream for verification.



Conventional demolition techniques should be employed for all painted surfaces with the Contractor complying with applicable OSHA and Cal/OSHA statutes regarding:

- Worker awareness training;
- Exposure monitoring, as needed;
- Medical examinations, which may include blood lead level testing; and
- Establishing a written respiratory protection program.

As lead was identified in most paints and a detailed inventory of paints was not performed for the project, for the purpose of complying with the Cal/OSHA lead in construction regulation (8 CCR 1532.1), all coated surfaces shall be considered to contain some lead and require demolition dust control procedures and presumed respiratory protection usage for compliance with Cal/OSHA's Construction Lead Standard under 8 CCR 1532.1. The aforementioned regulation contains requirements for lead air monitoring, work practices, respiratory protection, etc., that are triggered by the presence of any detected levels of lead.

Furthermore, coated metal to be torched/welded is required by CalOSHA to be spot-abated, regardless of the lead-content.

#### **Polychlorinated Biphenyls (PCB) & Mercury-Containing Items**

SCA quantified lighting ballasts that were observed in conjunction with mercury-containing, fluorescent lighting fixtures in various locations. The fixtures were not disassembled for inspection. Prior to renovation activities, the fixtures should be disassembled and the ballasts inspected to verify PCB content. If a "No PCB" stamp is not evident on the ballasts, they are likely to contain PCB. SCA also collected representative samples of building materials to determine PCB content.

The MMR (**Table 1**) shows detailed PCB sample results and locations of the sampled materials and quantified lighting fixtures. Sample locations are included on the sample location diagrams in **Attachment A** and laboratory reports in **Attachment D**. The following summarizes the results:

1. Results of the caulking and expansion joints sampled ranged from less than the laboratory's detection limits of 0.50 mg/kg to 0.28 mg/kg.
2. The result of the corrugated galbestos panels sampled was 11 mg/kg.
3. Ballasts associated with lighting fixtures are assumed to contain >50 mg/kg PCBs.

Cal/EPA regulates disposal of both PCB and mercury-containing materials. To reduce liability concerns, many building owners opt to have PCB ballasts incinerated, with a record of destruction generated. A slightly less expensive approach involves recycling of the components (and incineration of the small amount of PCB separately). However, this method may pose liability concerns for building owners.

Cal/EPA allows disposal as regular waste of up to 25 lamps per day per facility, although recycling vendors for reclaiming the mercury vapor are commonly available for services at approximately \$0.15 per lineal foot. Note that costs for fluorescent tube disposal do not tend to be significant compared to overall abatement costs.

**Silica**

Although not sampled or tested, it is common knowledge that sand is an integral component in concrete, and crystalline silica is also a confirmed component of sand. Various construction techniques, including saw-cutting, drilling, jack hammering, etc. are expected to release respirable silica thus triggering the currently applicable CalOSHA respirable silica standard (8 CCR 1532.3).

The standard requires employers to limit worker exposures to respirable crystalline silica and to take steps to protect workers. All construction employers covered by the standard are required to:

- Establish and implement a written exposure control plan that identifies tasks that involve exposure and methods used to protect workers, including procedures to restrict access to work areas where high exposures may occur.
- Designate a competent person to implement the written exposure control plan.
- Restrict housekeeping practices that expose workers to silica feasible alternatives are available.
- Offer medical exams – including chest x-rays and lung function tests – every three years for workers who are required by the standard to wear a respirator for 30 or more days per year.
- Train workers on work operations that result in silica exposures and ways to limit exposure.
- Keep records of workers' silica exposure and medical exams.

If you have any questions or would like more information, please contact us.

Sincerely,  
SCA ENVIRONMENTAL, INC.

Reviewed by:



Christina Codemo, CHMM, REPA, CAC  
President  
415-867-9540  
ccodemo@sca-enviro.com



Dan Leung, CIH, CSP, CAC, CDPH  
Vice President  
415-867-9544  
dleung@sca-enviro.com



**Table 1: Materials Matrix Report**

**Appendices:**

- |             |                             |
|-------------|-----------------------------|
| Appendix A: | Sample Location Drawings    |
| Appendix B: | Asbestos Laboratory Reports |
| Appendix C: | Lead Laboratory Reports     |
| Appendix D: | PCB Laboratory Reports      |

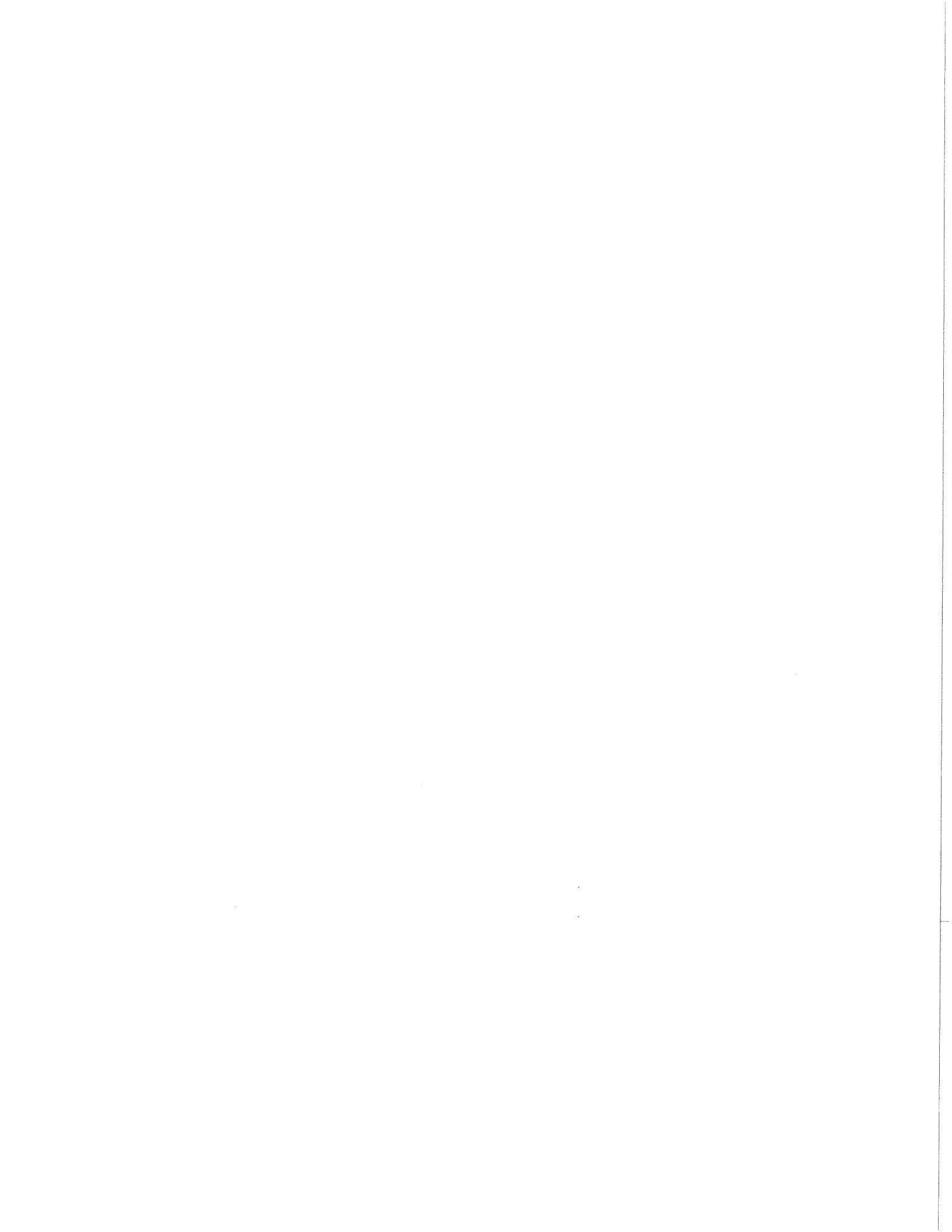



**Table 1: Materials Matrix Report-VTA Cerone Yard, Building F, 3990 Zanker Road, San Jose, CA 95134**

Material ID		Material Description		Sub-sample #			Asbestos? Positive. Trace. Assumed. Negative	UNITS (LF, SF, EA)	Interior	Exterior	TOTAL (+/-15%)
				A	B	C					
<b>ASBESTOS</b>											
CONC-2-1	Asbestos-containing gray resinous top layer over non-asbestos gray concrete pad for diesel generators [Sample #1 collected from top/side (SW corner) of SW generator pad]	4% CH resin			<b>Positive</b>	SF	225		225		
CONC-2-2	Asbestos-containing black tar top layer on non-asbestos gray concrete pad for diesel generators [Sample #2 collected from top/side (SE corner) of SE generator pad]		8% CH tar			SF	225		225		
GASKET-3	Beige gaskets at exhaust manifolds of diesel generators	75% CH	NA			EA	32		32		
GASKET-4	Beige gaskets between exhaust flanges near flue of diesel generators	85% CH	NA			EA	2		2		
GASKET-14	Black gasket between flanges of heating water pipes on boilers	60% CH	NA			EA	2		2		
GASKET-15	Beige gaskets at flanges of flue on boilers	70% CH	NA			EA	2		2		
GASKET-17	Off-white gasket between fan housing and ignition transformer on boilers	85% CH				EA	2		2		
WL-18	Off-white painted "galbestos" corrugated sheathing at dampers	60% CH	NA	NA		SF		500	500		
CAULK-20	Black caulking between fan shroud and metal wall panels	5% CH	NA			LF	80		80		
EXPJT-21	Non-asbestos gray caulking and asbestos-containing black tar over non-asbestos polystyrene around perimeter of non-asbestos gray concrete pads for diesel generators	3% CH	NA			LF	150		150		
<b>ASSUMED ASBESTOS (Destructive Testing Required to Confirm)</b>											
EL-AAA1	Electrical wiring in generator control panel (Not accessible at time of survey)				<b>Assumed</b>	LF	PNQ		PNQ		
EL-AAA2	Mounting plates in generator control panel (Not accessible at time of survey)					EA	PNQ		PNQ		
CONC-AAA3	Gray painted concrete stack bases (Not planned for demolition/removal)					SF		PNQ	PNQ		
<b>NON-ASBESTOS</b>											
FLUE-1	Off-white insulation w/canvas jacket on flues associated with diesel generators and boilers	ND	ND	ND	<b>Negative</b>	LF	200		200		
CONC-2-3	Gray concrete pad (-) for boiler pumps			ND		SF	30		30		
FLEX-5	Black canvas gaskets between air intake opening and fans of diesel generators	ND	ND			EA	2		2		
BLRIN-6	Off-white insulation on inside of doors of boilers	ND	ND			SF	100		100		
BLRIN-7	Off-white insulation on inside of boilers	ND	ND			SF	300		300		
GASKET-8	Off-white oven gasket around doors and openings of boilers	ND	ND	ND		EA	10		10		
PI-9	Fiberglass insulation w/paper and foil jacket on pipes near bottom of boilers	ND	ND			LF	10		10		
GASKET-10	Off-white gasket around view ports/access panels of boilers	ND				EA	8		8		
PLATE-11	Black fuse divider plates	ND				EA	6		6		
GASKET-12	Black rubber gasket between flanges of pipes on heating water supply and return pipes	ND				EA	12		12		
PIHW-13	Fiberglass insulation w/paper and foil jacket on heating water supply and return pipes and fittings	ND	ND	ND		LF	180	15	195		
STACK-16	Off-white insulation on inside of exterior metal stacks	ND	ND	ND		LF		200	200		
CAULK-19	Beige caulking around frames of air intakes (only observed around one damper)	ND				LF		20	20		
CONC-22	Gray concrete pad for diesel generators (samples collected on sides of concrete pad)	ND	ND			SF	450		450		
CONC-23	Gray concrete pad for electrical equipment (samples collected of top and sides of concrete pad)	ND	ND			SF	80		80		
CONC-24	Gray concrete pad for boilers (samples collected of top and sides of concrete pad)	ND	ND			SF	200		200		
CAULK-NNN	Red silicone at intake manifold area of diesel generators					LF	10		10		
CAULK-NNN	Clear silicone along seams of metal wall panels of dampers and around frames of air intakes					LF		250	250		
WL-NNN	Off-white painted metal damper double-layer wall panels with yellow foam between the two layers					SF		700	700		
					<b>Not Suspect</b>						



**Table 1: Materials Matrix Report-VTA Cerone Yard, Building F,  
3990 Zanker Road, San Jose, CA 95134**

Material ID		Material Description		Sub-sample #			Asbestos? Positive. Trace. Assumed. Negative	UNITS (LF, SF, EA)	Interior	Exterior	TOTAL (+/-15%)
				A	B	C					
<b>PCBs</b>											
<b>PPM</b>											
WL-18		Off-white painted "galbestos" corrugated panels at dampers					11	SF		500	500
CAULK-19		Beige caulking around frames of air intakes (only observed on one damper)					<0.50	LF		20	20
CAULK-20		Black caulking between fan shroud and metal wall panels					<0.50	LF	80		80
EXPJT-21		Non-asbestos gray caulking and asbestos-containing black tar over non-asbestos polystyrene around perimeter of non-asbestos gray concrete pads for diesel generators					0.28	LF	150		150
<b>LEAD</b>											
<b>PPM</b>											
OW-1		Off-white paint on hangers/bracing and supports for expansion tanks					226	SF	PNQ		PNQ
GR-2		Light olive-green paint on diesel generator 1					12452	SF	PNQ		PNQ
SI-3		Silver paint on air intake shroud of diesel generator 1					1728	SF	PNQ		PNQ
GY-4		Gray paint on diesel generator 2					2133	SF	PNQ		PNQ
GY-5		Dark gray paint on air intake shroud of diesel generator 2					1253	SF	PNQ		PNQ
GR-6		Dark green paint on boilers					3425	SF	PNQ		PNQ
RD-7		Red paint on boiler pumps					12929	SF	PNQ		PNQ
OW-8		Off-white paint on expansion tanks					307	SF	PNQ		PNQ
OW-9		Off-white paint on exterior metal stacks					6967	SF		PNQ	PNQ
OW-10		Off-white paint on exterior metal damper walls					4015	SF		PNQ	PNQ
Lead on steel		Lead Containing Coatings on Structural Steel (assumed >1000ppm)					Assumed, >1000	SF	PNQ		PNQ

**Notes:**

PNQ = Present, not quantified; CH = Chrysotile; ND = Not detected; NA = Not analyzed; pos = positive; neg = negative

## **Appendix A**

### **Sample Location Drawings**

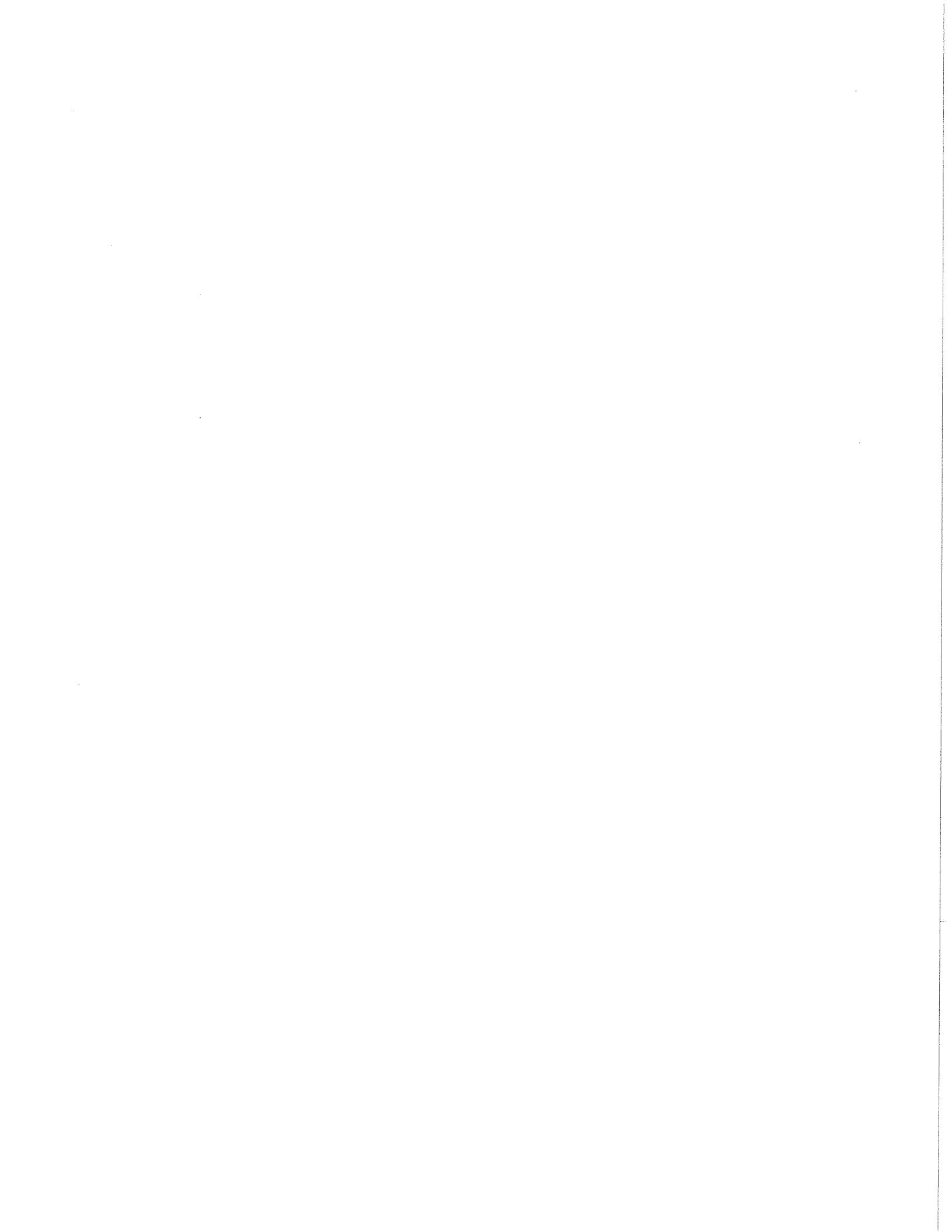



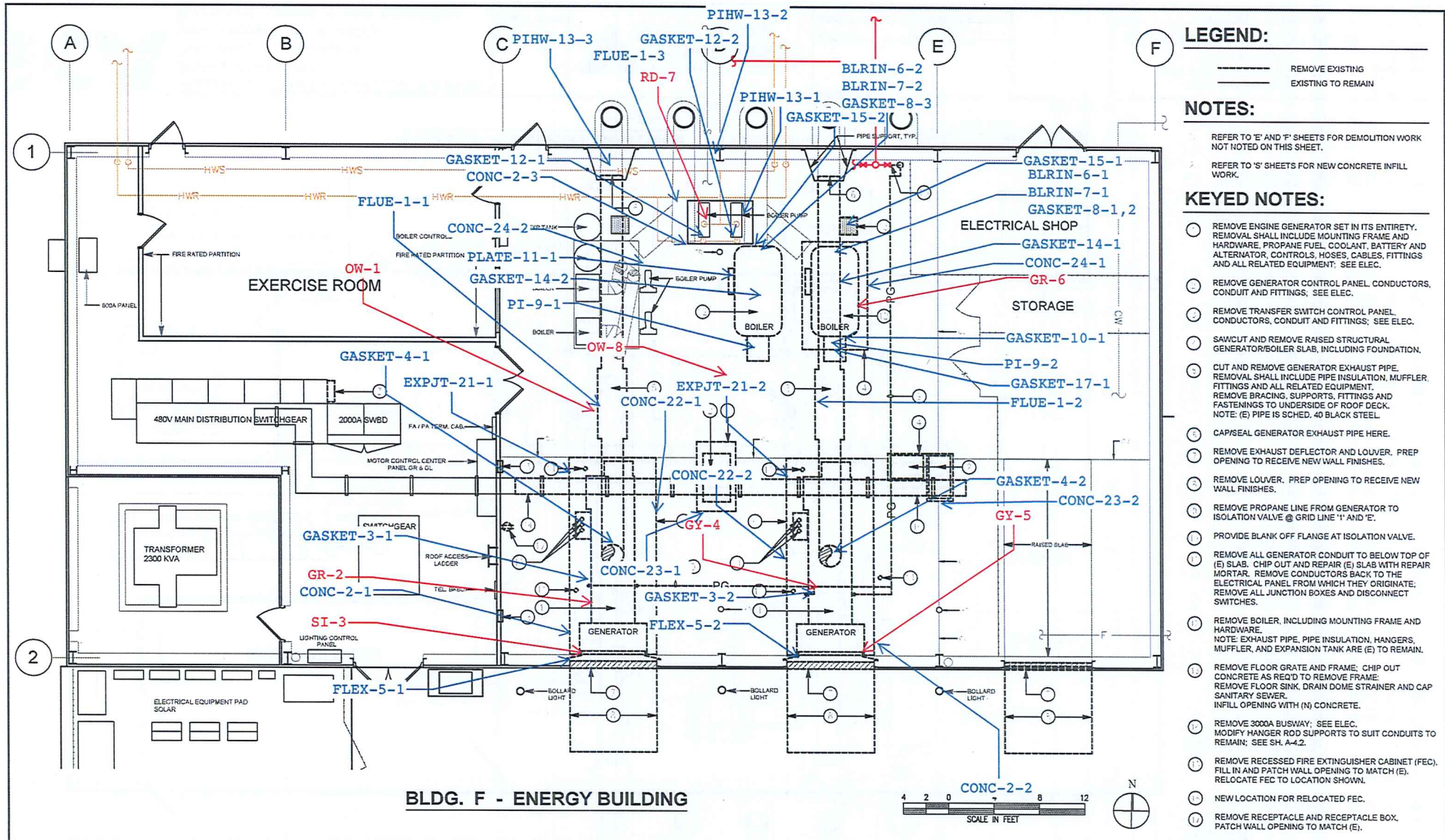

**LEGEND:**

- REMOVE EXISTING
- EXISTING TO REMAIN

**NOTES:**

- 1 REFER TO 'E' AND 'F' SHEETS FOR DEMOLITION WORK NOT NOTED ON THIS SHEET.
- 2 REFER TO 'S' SHEETS FOR NEW CONCRETE INFILL WORK.

**KEYED NOTES:**

- 1 REMOVE ENGINE GENERATOR SET IN ITS ENTIRETY. REMOVAL SHALL INCLUDE MOUNTING FRAME AND HARDWARE, PROPANE FUEL, COOLANT, BATTERY AND ALTERNATOR, CONTROLS, HOSES, CABLES, FITTINGS AND ALL RELATED EQUIPMENT; SEE ELEC.
- 2 REMOVE GENERATOR CONTROL PANEL, CONDUCTORS, CONDUIT AND FITTINGS; SEE ELEC.
- 3 REMOVE TRANSFER SWITCH CONTROL PANEL, CONDUCTORS, CONDUIT AND FITTINGS; SEE ELEC.
- 4 SAWCUT AND REMOVE RAISED STRUCTURAL GENERATOR/BOILER SLAB, INCLUDING FOUNDATION.
- 5 CUT AND REMOVE GENERATOR EXHAUST PIPE. REMOVAL SHALL INCLUDE PIPE INSULATION, MUFFLER, FITTINGS AND ALL RELATED EQUIPMENT. REMOVE BRACING, SUPPORTS, FITTINGS AND FASTENINGS TO UNDERSIDE OF ROOF DECK. NOTE: (E) PIPE IS SCHED. 40 BLACK STEEL
- 6 CAP/SEAL GENERATOR EXHAUST PIPE HERE.
- 7 REMOVE EXHAUST DEFLECTOR AND LOUVER. PREP OPENING TO RECEIVE NEW WALL FINISHES.
- 8 REMOVE LOUVER. PREP OPENING TO RECEIVE NEW WALL FINISHES.
- 9 REMOVE PROPANE LINE FROM GENERATOR TO ISOLATION VALVE @ GRID LINE '1' AND 'E'.
- 10 PROVIDE BLANK OFF FLANGE AT ISOLATION VALVE.
- 11 REMOVE ALL GENERATOR CONDUIT TO BELOW TOP OF (E) SLAB. CHIP OUT AND REPAIR (E) SLAB WITH REPAIR MORTAR. REMOVE CONDUCTORS BACK TO THE ELECTRICAL PANEL FROM WHICH THEY ORIGINATE. REMOVE ALL JUNCTION BOXES AND DISCONNECT SWITCHES.
- 12 REMOVE BOILER, INCLUDING MOUNTING FRAME AND HARDWARE. NOTE: EXHAUST PIPE, PIPE INSULATION, HANGERS, MUFFLER, AND EXPANSION TANK ARE (E), TO REMAIN.
- 13 REMOVE FLOOR GRATE AND FRAME. CHIP OUT CONCRETE AS REQ'D TO REMOVE FRAME. REMOVE FLOOR SINK. DRAIN DOME STRAINER AND CAP SANITARY SEWER. INFILL OPENING WITH (N) CONCRETE.
- 14 REMOVE 3000A BUSWAY; SEE ELEC. MODIFY HANGER ROD SUPPORTS TO SUIT CONDUITS TO REMAIN; SEE SH. A-4.2.
- 15 REMOVE RECESSED FIRE EXTINGUISHER CABINET (FEC). FILL IN AND PATCH WALL OPENING TO MATCH (E). RELOCATE FEC TO LOCATION SHOWN.
- 16 NEW LOCATION FOR RELOCATED FEC.
- 17 REMOVE RECEPTACLE AND RECEPTACLE BOX. PATCH WALL OPENING TO MATCH (E).



Figure 1. Sample Location Diagram  
 Santa Clara VTA  
 Building F, Interior  
 SCA Project #: F-12766  
 Surveyed August 9 and September 19, 2018



APPROVED	
DATE FILED	SCALE 1/4" = 1'-0"
FILED	BOUND OFFICIAL DATE

CERONE DIVISION  
 EMERGENCY GENERATOR  
 REPLACEMENT  
**DEMOLITION FLOOR PLAN**

SHEET	4
OF 33	
DATE	D-1.1
REVISION	

BAP NO. CONTRACT NO. C18063 FILE LOCATION



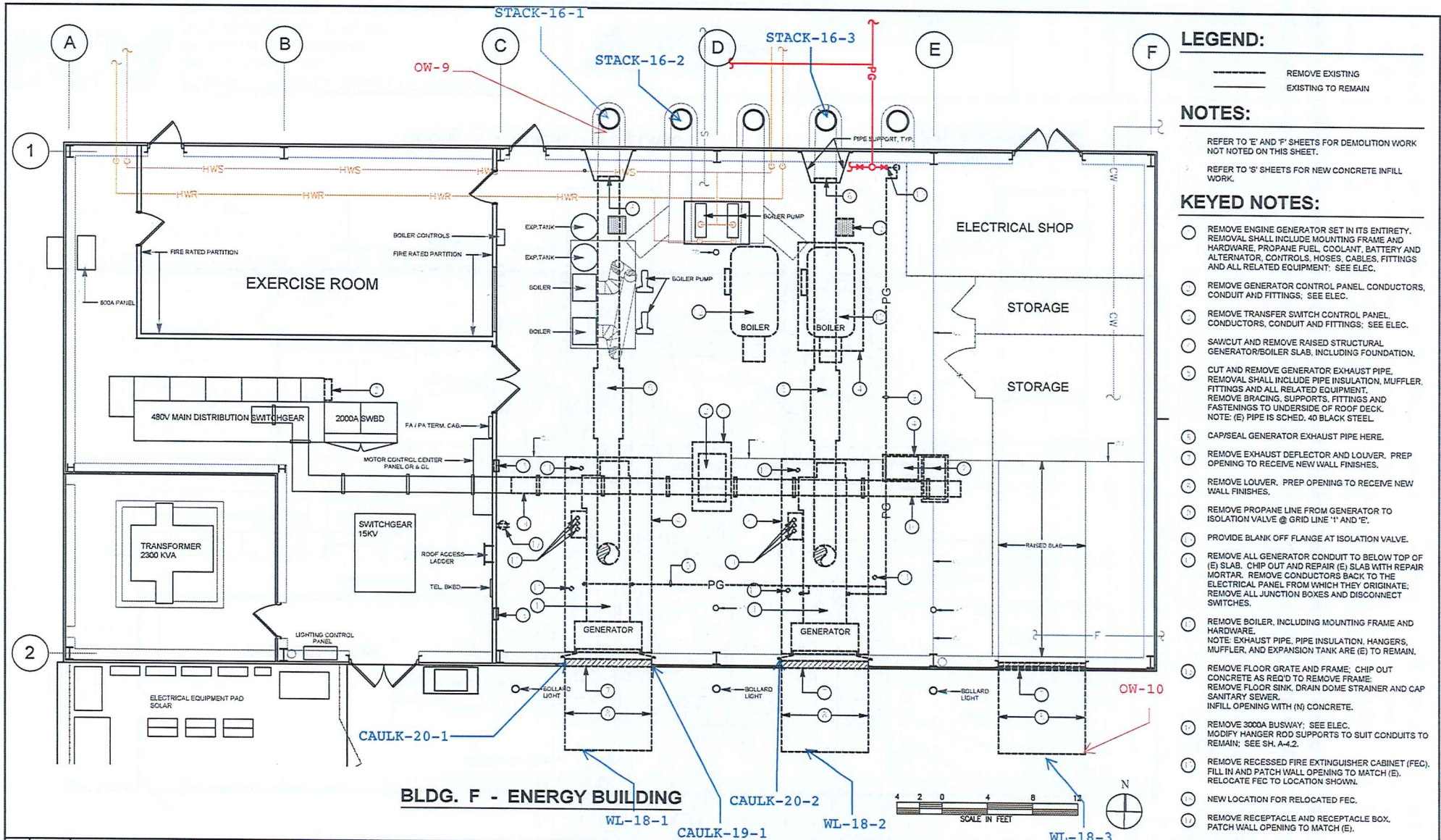

**LEGEND:**

- REMOVE EXISTING
- \_\_\_\_\_ EXISTING TO REMAIN

**NOTES:**

- 1 REFER TO 'E' AND 'F' SHEETS FOR DEMOLITION WORK NOT NOTED ON THIS SHEET.
- 2 REFER TO 'S' SHEETS FOR NEW CONCRETE INFILL WORK.

**KEYED NOTES:**

- 1 REMOVE ENGINE GENERATOR SET IN ITS ENTIRETY. REMOVAL SHALL INCLUDE MOUNTING FRAME AND HARDWARE, PROPANE FUEL, COOLANT, BATTERY AND ALTERNATOR, CONTROLS, HOSES, CABLES, FITTINGS AND ALL RELATED EQUIPMENT; SEE ELEC.
- 2 REMOVE GENERATOR CONTROL PANEL, CONDUCTORS, CONDUIT AND FITTINGS; SEE ELEC.
- 3 REMOVE TRANSFER SWITCH CONTROL PANEL, CONDUCTORS, CONDUIT AND FITTINGS; SEE ELEC.
- 4 SAWCUT AND REMOVE RAISED STRUCTURAL GENERATOR/BOILER SLAB, INCLUDING FOUNDATION.
- 5 CUT AND REMOVE GENERATOR EXHAUST PIPE. REMOVAL SHALL INCLUDE PIPE INSULATION, MUFFLER, FITTINGS AND ALL RELATED EQUIPMENT. REMOVE BRACING, SUPPORTS, FITTINGS AND FASTENINGS TO UNDERSIDE OF ROOF DECK. NOTE: (E) PIPE IS SCHED. 40 BLACK STEEL.
- 6 CAP/SEAL GENERATOR EXHAUST PIPE HERE.
- 7 REMOVE EXHAUST DEFLECTOR AND LOUVER. PREP OPENING TO RECEIVE NEW WALL FINISHES.
- 8 REMOVE LOUVER. PREP OPENING TO RECEIVE NEW WALL FINISHES.
- 9 REMOVE PROPANE LINE FROM GENERATOR TO ISOLATION VALVE @ GRID LINE '1' AND 'E'.
- 10 PROVIDE BLANK OFF FLANGE AT ISOLATION VALVE.
- 11 REMOVE ALL GENERATOR CONDUIT TO BELOW TOP OF (E) SLAB. CHIP OUT AND REPAIR (E) SLAB WITH REPAIR MORTAR. REMOVE CONDUCTORS BACK TO THE ELECTRICAL PANEL FROM WHICH THEY ORIGINATE. REMOVE ALL JUNCTION BOXES AND DISCONNECT SWITCHES.
- 12 REMOVE BOILER, INCLUDING MOUNTING FRAME AND HARDWARE. NOTE: EXHAUST PIPE, PIPE INSULATION, HANGERS, MUFFLER, AND EXPANSION TANK ARE (E) TO REMAIN.
- 13 REMOVE FLOOR GRATE AND FRAME. CHIP OUT CONCRETE AS REQ'D TO REMOVE FRAME. REMOVE FLOOR SINK, DRAIN DOME STRAINER AND CAP SANITARY SEWER. INFILL OPENING WITH (N) CONCRETE.
- 14 REMOVE 3000A BUSWAY; SEE ELEC. MODIFY HANGER ROD SUPPORTS TO SUIT CONDUITS TO REMAIN; SEE SH. A-4.2.
- 15 REMOVE RECESSED FIRE EXTINGUISHER CABINET (FEC). FILL IN AND PATCH WALL OPENING TO MATCH (E). RELOCATE FEC TO LOCATION SHOWN.
- 16 NEW LOCATION FOR RELOCATED FEC.
- 17 REMOVE RECEPTACLE AND RECEPTACLE BOX. PATCH WALL OPENING TO MATCH (E).

**BLDG. F - ENERGY BUILDING**



Figure 2. Sample Location Diagram  
 Santa Clara VTA  
 Building F, Exterior  
 SCA Project #: F-12766  
 Surveyed August 9 and September 19, 2018



JO  
 FILE NAME

APP'D	DATE
CHD FILE DATE	SCALE 1/4" = 1'-0"
PLD DATE	DESIGN APPROVAL DATE

CERONE DIVISION EMERGENCY GENERATOR REPLACEMENT			SHEET 4
DEMOLITION FLOOR PLAN			DATE D-1.1
MAP NO.	CONTRACT NO. C18053	FILE LOCATION	REVISION

## **Appendix B**

### **Asbestos Laboratory Reports**



September 14, 2018

**Subcontract Number:** NA  
**Laboratory Report:** RES 416021-1R  
**Project # / P.O. #** F-12766  
**Project Description:** SC VTA, Bldg. F, SJ

Christina Codemo  
SCA Environmental, Inc.  
650 Delancey St. Ste. 222  
San Francisco CA 94107

Dear Customer,

Reservoirs Environmental, Inc. is an analytical laboratory accredited for the analysis of Industrial Hygiene and Environmental matrices by the National Voluntary Laboratory Accreditation Program (NVLAP), Lab Code 101896-0 for Transmission Electron Microscopy (TEM) and Polarized Light Microscopy (PLM) analysis and the American Industrial Hygiene Association (AIHA), Lab ID 101533 - Accreditation Certificate #480 for Phase Contrast Microscopy (PCM) analysis. This laboratory is currently proficient in both Proficiency Testing and PAT programs respectively.

Reservoirs Environmental, Inc. has analyzed the following samples for asbestos content as per your request. The analysis has been completed in general accordance with the appropriate methodology as stated in the attached analysis table. The results have been submitted to your office.

**RES 416021-1R** is the job number assigned to this study. This report is considered highly confidential and the sole property of the customer. Reservoirs Environmental, Inc. will not discuss any part of this study with personnel other than those of the client. The results described in this report only apply to the samples analyzed. This report must not be used to claim endorsement of products or analytical results by NVLAP or any agency of the U.S. Government. This report shall not be reproduced except in full, without written approval from Reservoirs Environmental, Inc. Samples will be disposed of after sixty days unless longer storage is requested. If you have any questions about this report, please feel free to call 303-964-1986.

Sincerely,

A handwritten signature in blue ink, appearing to read "Jeanne Spencer". Below the signature, the name "Jeanne Spencer" is printed in a small, light blue font.

Jeanne Spencer  
President

## RESERVOIRS ENVIRONMENTAL INC.

NVLAP Lab Code 101896-0

**TABLE: PLM BULK ANALYSIS, PERCENTAGE COMPOSITION BY VOLUME**

RES Job Number: RES 416021-1R  
 Client: SCA Environmental, Inc.  
 Client Project Number / P.O.: F-12766  
 Client Project Description: SC VTA, Bldg. F, SJ  
 Date Samples Received: August 13, 2018  
 Method: EPA 600/R-93/116 - Short Report, Bulk  
 Turnaround: Standard  
 Date Samples Analyzed: August 16, 2018

ND=None Detected  
 TR=Trace, <1% Visual Estimate  
 Trem/Act=Tremolite/Actinolite

Client Sample Number	Lab ID Number	L A Y E R	Physical Description	Sub Part (%)	Asbestos Content		Non-Asbestos Fibrous Components (%)	Non-Fibrous Components (%)
					Mineral	Visual Estimate (%)		
FLUE-1-1	EM 2145921	A	Gray paint w/ white resinous material	5			0	100
		B	White woven material	12			95	5
		C	Gray fibrous plaster	83			35	65
FLUE-1-2	EM 2145922	A	Gray paint white resinous material	5			0	100
		B	White woven	12			95	5
		C	Gray fibrous plaster	83			35	65
FLUE-1-3	EM 2145923	A	Light gray paint	2			0	100
		B	White woven material	10			95	5
		C	Light gray-white fibrous plaster	88			35	65
CONC-2-1	EM 2145924	A	Gray resinous	1		Chrysotile	0	96
		B	Gray cementitious	99			0	100
CONC-2-2	EM 2145925	A	Black tar	1		Chrysotile	0	92
		B	Gray cementitious material	99			0	100
CONC-2-3	EM 2145926	A	Gray cementitious material	100			0	100

TEM Analysis recommended for organically bound material (i.e. floor tile) if PLM results are <1%.



## RESERVOIRS ENVIRONMENTAL INC.

NVLAP Lab Code 101896-0

**TABLE: PLM BULK ANALYSIS, PERCENTAGE COMPOSITION BY VOLUME**

RES Job Number: RES 416021-1R  
 Client: SCA Environmental, Inc.  
 Client Project Number / P.O.: F-12766  
 Client Project Description: SC VTA, Bldg. F, SJ  
 Date Samples Received: August 13, 2018  
 Method: EPA 600/R-93/116 - Short Report, Bulk  
 Turnaround: Standard  
 Date Samples Analyzed: August 16, 2018

ND=None Detected  
 TR=Trace, <1% Visual Estimate  
 Trem/Act=Tremolite/Actinolite

Client Sample Number	Lab ID Number	L A Y E R	Physical Description	Sub Part (%)	Asbestos Content		Non-Fibrous Components (%)
					Mineral	Visual Estimate (%)	
GASKET-3-1	EM 2145927	A	Silver paint	35	ND	0	100
GASKET-3-2	EM 2145928	B	Off white fibrous resinous material	65	75	0	25
GASKET-4-1	EM 2145929	Not Analyzed per Client Request.					
GASKET-4-2	EM 2145930	A	Grayish-off white fibrous material	100	85	0	15
FLEX-5-1	EM 2145931	Not Analyzed per Client Request.					
FLEX-5-2	EM 2145932	A	Black fibrous resinous material	100	ND	30	70
BLRIN-6-1	EM 2145933	A	White plaster	100	ND	30	70
BLRIN-6-2	EM 2145934	B	Pink-white fireproofing brick	2	ND	0	100
BLRIN-7-1	EM 2145935	A	Pink-white fireproofing brick	98	ND	0	100
BLRIN-7-2	EM 2145936	A	Light gray-brown granular material	100	ND	0	100
GASKET-8-1	EM 2145937	A	Pink fireproofing	40	ND	0	100
		B	Pink/orange-tan granular material	60	ND	0	100
		A	Tan-white fibrous material	100	ND	90	10

TEM Analysis recommended for organically bound material (i.e. floor tile) if PLM results are <1%.

## RESERVOIRS ENVIRONMENTAL INC.

NVLAP Lab Code 101896-0

**TABLE: PLM BULK ANALYSIS, PERCENTAGE COMPOSITION BY VOLUME**

RES Job Number: RES 416021-1R  
 Client: SCA Environmental, Inc.  
 Client Project Number / P.O.: F-12766  
 Client Project Description: SC VTA, Bldg. F, SJ  
 Date Samples Received: August 13, 2018  
 Method: EPA 600/R-93/116 - Short Report, Bulk  
 Turnaround: Standard  
 Date Samples Analyzed: August 16, 2018

ND=None Detected  
 TR=Trace, <1% Visual Estimate  
 Trem/Act=Tremolite/Actinolite

Client Sample Number	Lab ID Number	L A Y E R	Physical Description	Sub Part (%)	Asbestos Content		Non-Fibrous Components (%)
					Mineral	Visual Estimate (%)	
GASKET-8-2	EM 2145938	A	Brown-white fibrous material	100	ND	80	20
GASKET-8-3	EM 2145939	A	Brown/white fibrous material	100	ND	90	10
PI-9-1	EM 2145940	A	Tan/silver wrap	25	ND	50	50
		B	Tan fibrous material	75	ND	95	5
PI-9-2	EM 2145941	A	Tan/silver wrap w/ gray paint	20	ND	50	50
		B	Yellow fibrous material	80	ND	95	5
GASKET-10-1	EM 2145942	A	Brown-white fibrous material	100	ND	80	20
PLATE-11-1	EM 2145943	A	Black fibrous resinous material	100	ND	60	40
GASKET-12-1	EM 2145944	A	Black resinous material	100	ND	0	100
GASKET-12-2	EM 2145945	A	Black resinous material	100	ND	0	100
PIHW-13-1	EM 2145946	A	Light gray paint	1	ND	0	100
		B	White/silver wrap	5	ND	50	50
		C	Tan fibrous material	94	ND	95	5

TEM Analysis recommended for organically bound material (i.e. floor tile) if PLM results are <1%.

## RESERVOIRS ENVIRONMENTAL INC.

NVLAP Lab Code 101896-0

**TABLE: PLM BULK ANALYSIS, PERCENTAGE COMPOSITION BY VOLUME**

RES Job Number: RES 416021-1R  
 Client: SCA Environmental, Inc.  
 Client Project Number / P.O.: F-12766  
 Client Project Description: SC VTA, Bldg. F, SJ  
 Date Samples Received: August 13, 2018  
 Method: EPA 600/R-93/116 - Short Report, Bulk  
 Turnaround: Standard  
 Date Samples Analyzed: August 16, 2018

ND=None Detected  
 TR=Trace, <1% Visual Estimate  
 Trem/Act=Tremolite/Actinolite

Client Sample Number	Lab ID Number	Physical Description	Sub Part (%)	Asbestos Content		Non-Fibrous Components (%)
				Mineral	Visual Estimate (%)	
PIHW-13-2	EM 2145947	A Gray paint	1		ND	100
		B White/silver wrap	5		ND	50
		C Tan fibrous material	94		ND	95
PIHW-13-3	EM 2145948	A White/silver wrap	3		ND	50
		B Gray paint w/ off white resinous material	7		ND	0
		C Tan resinous material	90		ND	95
GASKET-14-1	EM 2145949	A Dark gray fibrous resinous material	100	Chrysotile	60	40
		Not Analyzed per Client Request.				
GASKET-14-2	EM 2145950	A Off white fibrous material	100	Chrysotile	70	10
		Not Analyzed per Client Request.				
GASKET-15-1	EM 2145951	A White/multi-colored paint	5		ND	100
		B Gray fibrous plaster	25		ND	80
GASKET-15-2	EM 2145952	C White plaster	70		ND	100
STACK-16-1	EM 2145953					

TEM Analysis recommended for organically bound material (i.e. floor tile) if PLM results are <1%.

# RESERVOIRS ENVIRONMENTAL INC.

NVLAP Lab Code 101896-0

**TABLE: PLM BULK ANALYSIS, PERCENTAGE COMPOSITION BY VOLUME**

RES Job Number: RES 416021-1R  
 Client: SCA Environmental, Inc.  
 Client Project Number / P.O.: F-12766  
 Client Project Description: SC VTA, Bldg. F, SJ  
 Date Samples Received: August 13, 2018  
 Method: EPA 600/R-93/116 - Short Report, Bulk Standard  
 Turnaround: August 16, 2018  
 Date Samples Analyzed:

ND=None Detected  
 TR=Trace, <1% Visual Estimate  
 Trem/Act=Tremolite/Actinolite

Client Sample Number	Lab ID Number	L A Y E R	Physical Description	Sub Part (%)	Asbestos Content		Non-Fibrous Components (%)	
					Mineral	Visual Estimate (%)		
STACK-16-2	EM 2145954	A	White paint	1		ND	0	100
		B	White paint w/ gray plaster	4		ND	0	100
		C	Purple-grayish fibrous resinous material	5		ND	95	5
		D	White plaster	90		ND	0	100
STACK-16-3	EM 2145955	A	Light gray-white paint w/ white plaster	100		ND	12	88
		A	Gray fibrous material	100		85	5	10
GASKET-17-1	EM 2145956	A	Black fibrous tar	40		60	10	30
		B	White/gray paint	60		ND	0	100
WL-18-2	EM 2145958		Not Analyzed per Client Request.					
WL-18-3	EM 2145959		Not Analyzed per Client Request.					
CAULK-19-1	EM 2145960	A	Gray resinous material w/ white paint	100		ND	0	100
CAULK-20-1	EM 2145961	A	Gray fibrous resinous material	100		5	0	95
CAULK-20-2	EM 2145962		Not Analyzed per Client Request.					

TEM Analysis recommended for organically bound material (i.e. floor tile) if PLM results are <1%.

*Anita Grigg*  
 Anita Grigg  
 Analyst / Data QA



# REILAB Reservoirs Environmental, Inc.

5801 Logan St. Denver, CO 80216 • Ph: 303 964-1986 • Fax: 303-477-4275 • Toll Free: 866-RES-ENV

After Hours Cell Phone: 720-339-9228

Due Date: \_\_\_\_\_  
Due Time: \_\_\_\_\_

**SUBMITTED BY:**

Company: **SCA Environmental, Inc.**  
Address: 650 Delancey St. Ste. 222  
San Francisco CA 94107

**CONTACT INFORMATION:**

Contact: **Christina Codemo**  
Phone: \_\_\_\_\_  
Fax: \_\_\_\_\_  
Cell/pager: \_\_\_\_\_

Final Data Deliverable Email Address: \_\_\_\_\_

**INVOICE TO: (IF DIFFERENT)**

Company: \_\_\_\_\_  
Address: \_\_\_\_\_  
Project Number and/or P.O. #: F-12766  
Project Description/Location: SC VTA, Bldg. F, SJ

Client sample ID number (Sample ID's must be unique)	REQUESTED ANALYSIS		VALID MATRIX CODES		LAB NOTES:												
	PLM - Short report, Point Count, Long report, Qualitative	TEM - AHERA, Level II, 7402, ISO +/- (Air, Bulk or Dust), Quant, Semi-Quant, Micro-vec, ISO-Indirect Preps	PCB - 7400A, 7400B, OSHA	DUST - Total, Respirable		METALS - Analyte(s) RCRA 8, TCLP, Welding Fume, Metals Scan, pH	ORGANICS - METH, TSS	Pathogens: Aerobic Plate Count, Salmonella, E. coli, O157:H7, Listeria, S. aureus, Campylobacter, +/- or Quantification	E. coli and/or Coliforms: +/- or Quantification	State Water (Phase Circle One) Yes / No	Microbial Growth: Aerobic Plate Count ID, Y & M or Bacteria, Fungal, +/- or Quantification	Legionella +/- or Quantification	Other: BioBurden, LAL or Environmental Mold, Spore Trap or Bulk +/-, Identification, Quantification, Viable or Non-Viable	SAMPLER'S INITIALS OR OTHER NOTES:	Matrix Code	Date Collected mm/dd/yyyy	Time Collected hh:mm:ap
1 FLUE-1-1	X																2145921
2 FLUE-1-2	X																2145922
3 FLUE-1-3	X																2145923
4 CONC-2-1	X																2145924
5 CONC-2-2	X																2145925
6 CONC-2-3	X																2145926
7 GASKET-3-1	X																2145927
8 GASKET-3-2	X																2145928
9 GASKET-4-1	X																2145929
10 GASKET-4-2	X																2145930

Number of samples received: 42 (Additional samples shall be listed on attached long form.)

NOTE: REI will analyze incoming samples based upon information received and will not be responsible for errors or omissions resulting from the inaccuracy of original data. By signing client/company representative agrees that submission of the following samples for requested analysis as indicated on this Chain of Custody shall constitute an analytical services agreement with payment terms of NET 30 days, failure to comply with payment terms may result in a 1.5% monthly interest surcharge.

Relinquished By:		Date/Time:		Date/Time:		Date/Time:		Date/Time:		Date/Time:		Date/Time:		Date/Time:		Date/Time:	
Contact	Initials	Phone	Time	Initials	Time	Phone	Time	Initials	Time	Phone	Time	Initials	Time	Phone	Time	Initials	Time
_____	_____	813	18:00	_____	_____	_____	_____	_____	_____	_____	_____	_____	_____	_____	_____	_____	_____
_____	_____	_____	_____	_____	_____	_____	_____	_____	_____	_____	_____	_____	_____	_____	_____	_____	_____



RES #: 416021-1

Page 2 of 3

Submitted by: SCA Environmental, Inc.

Client sample ID number (Sample ID's must be unique)	REQUESTED ANALYSIS										VALID MATRIX CODES					LAB NOTES:			
	PM - Short report, Long report, Point Count	TM - AHERA, Level II, 7402, ISO, +/-, Quant, Sem-quant, Micro-vac, ISO-Indirect Preps	PCM - 7400A, 7400B, OSHA	DUST - Total, Respirable	METALS - Analyte(s) RCRA 8, TCLP, Welding Fume, Metals Scan	ORGANICS - METH, TSS	Pathogens: Aerobic Plate Count, Salmonella, E. coli O157:H7, Listeria, S. aureus, Campylobacter, +/- or Quantification	E. coli and/or Coliforms: +/- or Quantification	State Water (Please Circle One) Yes / No	Microbial Growth: Aerobic Plate Count ID, Y & M or Bacteria, Fungal, +/- or Quantification	Legionella: +/- or Quantification	Other: Burden, LAL or Environmental	Mold, Spore Trap or Bulk: +/-, Identification, Quantification, Viable or Non-Viable	SAMPLER'S INITIALS OR OTHER NOTES:	Sample Volume (l) / Area		Matrix Code	# Containers	Date Collected mm/dd/yyyy
11 FLEX-5-1	X																		2145931
12 FLEX-5-2	X																		2145932
13 BLRIN-6-1	X																		2145933
14 BLRIN-6-2	X																		2145934
15 BLRIN-7-1	X																		2145935
16 BLRIN-7-2	X																		2145936
17 GASKET-8-1	X																		2145937
18 GASKET-8-2	X																		2145938
19 GASKET-8-3	X																		2145939
20 PI-9-1	X																		2145940
21 PI-9-2	X																		2145941
22 GASKET-10-1	X																		2145942
23 PLATE-11-1	X																		2145943
24 GASKET-12-1	X																		2145944
25 GASKET-12-2	X																		2145945
26 PIHW-13-1	X																		2145946
27 PIHW-13-2	X																		2145947
28 PIHW-13-3	X																		2145948
29 GASKET-14-1	X																		2145949
30 GASKET-14-2	X																		2145950
31 GASKET-15-1	X																		2145951
32 GASKET-15-2	X																		2145952
33 STACK-16-1	X																		2145953
34 STACK-16-2	X																		2145954
35 STACK-16-3	X																		2145955
36 GASKET-17-1	X																		2145956
37 WL-18-1	X																		2145957
38 WL-18-2	X																		2145958
39 WL-18-3	X																		2145959
40 CAULK-19-1	X																		2145960
41 CAULK-20-1	X																		2145961



RES #: 416021-1

Page 3 of 3

Submitted by: SCA Environmental, Inc.

Client sample ID number (Sample ID's must be unique)	REQUESTED ANALYSIS	VALID MATRIX CODES	LAB NOTES:
42 CAULK-20-2	<p><b>PLM</b> - Short report, Long report, Point Count</p> <p><b>TEM</b> - AHERA, Level II, 7402, ISO, +/-, Quant, Semi-quant, Micro-vac, ISO-Indirect Preps</p> <p><b>PCM</b> - 7400A, 7400B, OSHA</p> <p><b>DUST</b> - Total, Respirable</p> <p><b>METALS</b> - Analyte(s) _____</p> <p><b>RCRA 8, TCLP, Welding Fume, Metals Scan</b></p> <p><b>ORGANICS</b> - METH, TSS</p> <p><b>Pathogens:</b> Aerobic Plate Count, Salmonella, E. coli O157:H7, Listeria, Staphylococcus aureus, Campylobacter, +/- or Quantification</p> <p><b>E. coli and/or Coliforms:</b> +/- or Quantification</p> <p><b>State Water (Please Circle One)</b> Yes / No</p> <p><b>Microbial Growth:</b> Aerobic Plate Count ID, Y &amp; M or Bacteria, Fungal, +/- or Quantification</p> <p><b>Legionella:</b> +/- or Quantification</p> <p><b>Other Bioburden:</b> LAL or Environmental Mold: Spore Trap or Bulk: +/-, Identification, Quantification, Viable or Non-Viable</p> <p><b>SAMPLER'S INITIALS OR OTHER NOTES:</b></p>	<p>Air = A      Bulk = B</p> <p>Dust = D      Paint = P</p> <p>Soil = S      Wipe = W</p> <p>Swab = SW      F = Food</p> <p>Drinking Water = DW      Waste Water = WW</p> <p>O = Other</p> <p>**ASTM E1792 approved wipe media only**</p>	<p><b>EM Number</b> (Laboratory Use Only)</p> <p>2145962</p>
43			
44			
45			
46			
47			
48			
49			
50			
51			
52			
53			
54			
55			
56			
57			
58			
59			
60			
61			
62			
63			
64			
65			
66			
67			
68			
69			
70			
71			
72			



416021

**CHAIN OF CUSTODY FORM**

Bill to: GCA

Email report/COC/Invoice to:

CHRISTINA CODEMO (PROJ MGR)

EMAIL HEADING: (Project #) - (Project Manager Initials) - (Site Name/Address) (Date MMDD)  
BM SC VTA F-12766 CC SC VTA, BLDG. F, 8/9  
BLDG F SVY GS

Dan Leung (TECH)

LAB REI

labreports99@gmail.com (ACCT)

COURIER  
 LAB REP NOTIFIED \_\_\_\_\_ Notification DATE/TIME \_\_\_\_\_  
 AIRBILL/FLIGHT NO. \_\_\_\_\_ Shipper REFERENCE ID \_\_\_\_\_  
 EST ARRIVAL DATE \_\_\_\_\_ EST ARRIVAL TIME \_\_\_\_\_

INSTRUCTIONS TO LAB:

Method Reference 7400 PCM AHERA TEM (±0.005 s/cc Analen) CARB-AHERA TEM 0.001 s/cc Ana Sensitivity  
PLM (asbestos) Flame AA (Lead) ICP/MS (Lead)  
 Sample Media 25 37 mm 0.45 0.8 micron MCEF Bulk Water Wipe

RESULTS DUE: 3 DAYS AM / PM

CHAIN OF CUSTODY DATA:  
 Sending Info 42 samples submitted by DL on 8/10 at 4:00 P  
 Received by Lab: \_\_\_\_\_ samples received by \_\_\_\_\_ on \_\_\_\_\_ at \_\_\_\_\_  
 Received by Analyst: \_\_\_\_\_ samples received by \_\_\_\_\_ on \_\_\_\_\_ at \_\_\_\_\_

SAMPLE ID	LITERS	Results	Ins/Blanks/Outs
<u>FLUE-1-1,2,3</u>		<u>CAULK-20-1,2</u>	
<u>CONC-2-1,2,3</u>			
<u>GASKET-3-1,2</u>			
<u>GASKET-4-1,2</u>			
<u>FLEX-5-1,2</u>			
<u>BLRIW-6-1,2</u>			
<u>BLRIW-7-1,2</u>			
<u>GASKET-8-1,2,3</u>			
<u>PI-9-1,2</u>			
<u>GASKET-10-1</u>			
<u>PLATE-11-1</u>			
<u>GASKET-12-1,2</u>			
<u>PIHW-13-1,2,3</u>			
<u>GASKET-14-1,2</u>			
<u>GASKET-15-1,2</u>			
<u>STACK-16-1,2,3</u>			
<u>GASKET-17-1</u>	<u>0 LITERS</u>		<u>BLANK</u>
<u>WL-18-1,2,3</u>	<u>0 LITERS</u>		<u>BLANK</u>
<u>CAULK-19-1</u>	<u>0 LITERS</u>		<u>BLANK</u>

INSTRUCTIONS TO LAB (delete items not applicable AND circle items applicable):

- Pickup requested.  
 Contact \_\_\_\_\_ Time of Call \_\_\_\_\_
- Call contact to acknowledge receipt of samples.
- Analyze samples by PCM only.
- Analyze inside samples by PCM first; if any sample >0.01 f/cc, contact project manager.
- If all samples are <0.01 f/cc, proceed with items 6, 7 or 8, as noted.
- Analyze inside samples only, stop if Avg >70 str/mm<sup>2</sup>, contact PM before analyzing outsides or blanks
- Analyze all samples, including outside samples and blanks.
- Do NOT analyze outside or blank samples.
- Analyze by TEM only the inside air sample with the highest PCM result.
- Serial analysis; stop at first positive (>1%); first trace (<0.1%); except sheetrock and plaster samples
- Analyze all bulk samples, unless otherwise indicated.
- PCB: 1 PPM detection limit required. Authorized to perform Florisil cleanup and Soxhlet extraction to meet the detection limit.
- For AHERA TEM, only analyze for REGULATED ASBESTOS.
- \_\_\_\_\_

Report Number:	Supplies /Equipment	Qty
	Hi-Vol (3040)	
	Lo-Vol (3020)	
Invoice Number:	TEM / Pb cassettes (3520)	
	PCM cassettes (3500)	
	Bulk sampling supply (3710)	<u>42</u>



September 24, 2018

**Subcontract Number:** NA  
**Laboratory Report:** RES 418694-1  
**Project # / P.O. #** F12766.01  
**Project Description:** VTA, Cerone Yard, Bldg. F

Christina Codemo  
SCA Environmental, Inc.  
650 Delancey St. Ste. 222  
San Francisco CA 94107

Dear Customer,

Reservoirs Environmental, Inc. is an analytical laboratory accredited for the analysis of Industrial Hygiene and Environmental matrices by the National Voluntary Laboratory Accreditation Program (NVLAP), Lab Code 101896-0 for Transmission Electron Microscopy (TEM) and Polarized Light Microscopy (PLM) analysis and the American Industrial Hygiene Association (AIHA), Lab ID 101533 - Accreditation Certificate #480 for Phase Contrast Microscopy (PCM) analysis. This laboratory is currently proficient in both Proficiency Testing and PAT programs respectively.

Reservoirs Environmental, Inc. has analyzed the following samples for asbestos content as per your request. The analysis has been completed in general accordance with the appropriate methodology as stated in the attached analysis table. The results have been submitted to your office.

**RES 418694-1** is the job number assigned to this study. This report is considered highly confidential and the sole property of the customer. Reservoirs Environmental, Inc. will not discuss any part of this study with personnel other than those of the client. The results described in this report only apply to the samples analyzed. This report must not be used to claim endorsement of products or analytical results by NVLAP or any agency of the U.S. Government. This report shall not be reproduced except in full, without written approval from Reservoirs Environmental, Inc. Samples will be disposed of after sixty days unless longer storage is requested. If you have any questions about this report, please feel free to call 303-964-1986.

Sincerely,

A handwritten signature in blue ink, appearing to read "Jeanne Spencer".

*Jeanne Spencer*  
Jeanne Spencer for

Jeanne Spencer  
President



# RESERVOIRS ENVIRONMENTAL INC.

NVLAP Lab Code 101896-0

**TABLE: PLM BULK ANALYSIS, PERCENTAGE COMPOSITION BY VOLUME**

RES Job Number: RES 418694-1  
 Client: SCA Environmental, Inc.  
 Client Project Number / P.O.: F12766.01  
 Client Project Description: VTA, Cerone Yard, Bldg. F  
 Date Samples Received: September 20, 2018  
 Method: EPA 600/R-93/116 - Short Report, Bulk  
 Turnaround: Priority  
 Date Samples Analyzed: September 24, 2018

ND=None Detected  
 TR=Trace, <1% Visual Estimate  
 Trem/Act=Tremolite/Actinolite

Client Sample Number	Lab ID Number	L A Y E R	Physical Description	Sub Part (%)	Asbestos Content		Non-Fibrous Components (%)
					Mineral	Visual Estimate (%)	
EXPJT-21-1	EM 2167801	A	Black tar	TR	3	Chrysotile	97
EXPJT-21-2	EM 2167802	B	Gray resinous material	100	ND		100
CONC-22-1	EM 2167803	A	Not Analyzed per Client Request	5	ND		100
		B	Dark gray plaster	95	ND		100
CONC-22-2	EM 2167804	A	Gray cementitious material	10	ND		100
		B	Gray-brown plaster	90	ND		100
CONC-23-1	EM 2167805	A	Gray cementitious material	100	ND		100
CONC-23-2	EM 2167806	A	Gray cementitious material	100	ND		100
CONC-24-1	EM 2167807	A	Gray cementitious material	100	ND		100
CONC-24-2	EM 2167808	A	Gray cementitious material	100	ND		100

TEM Analysis recommended for organically bound material (i.e. floor tile) if PLM results are <1%.

*Anita Grigg*  
 Anita Grigg  
 Analyst / Data QA











## **Appendix C**

### **Lead Laboratory Reports**



August 16, 2018

Laboratory Code: RES  
Subcontract Number: NA  
Laboratory Report: RES 416020-1  
Project # / PO #: F12766  
Project Description: SC VTA, Bldg. F, SJ

Christina Codemo  
SCA Environmental, Inc.  
650 Delancey St. Ste. 222  
San Fransisco CA 94107

Dear Customer,

Reservoirs Environmental, Inc. is an analytical laboratory accredited for the analysis of Industrial Hygiene and Environmental matrices by the American Industrial Hygiene Association, Lab ID 101533 - Accreditation Certificate #480. The laboratory is currently proficient in both IHPAT & ELPAT programs respectively.

Reservoirs has analyzed the following sample(s) using Atomic Absorption Spectroscopy (AAS) / Atomic Emission Spectroscopy - Mass Spectrometry (ICP-MS) per your request. Reported sample results were not blank corrected. The analysis has been completed in general accordance with the appropriate methodology as stated in the analysis table. Results have been sent to your office.

**RES 416020-1** is the job number assigned to this study. This report is considered highly confidential and the sole property of the customer. Reservoirs Environmental, Inc. will not discuss any part of this study with personnel other than those authorized by the client. The results described in this report only apply to the samples analyzed. This report shall not be reproduced except in full, without written approval from Reservoirs Environmental, Inc. Samples will be disposed of after sixty days unless longer storage is requested. If you should have any questions about this report, please feel free to call me at 303-964-1986.

Sincerely,

A handwritten signature in blue ink that reads "Jeanne Spencer". The signature is written in a cursive, flowing style.

Jeanne Spencer  
President

**RESERVOIRS ENVIRONMENTAL, INC.**  
**5801 Logan St., Suite 100**  
**Denver CO 80216**

**TABLE ANALYSIS: LEAD IN BULK**

RES Job Number: **RES 416020-1**  
 Client: **SCA Environmental, Inc.**  
 Client Project Number / P.O.: **F12766**  
 Client Project Description: **SC VTA, Bldg. F, SJ**  
 Date Samples Received: **August 13, 2018**  
 Analysis Type: **USEPA SW846 3050B / 6020A**  
 Turnaround: **Priority**  
 Date Samples Analyzed: **August 16, 2018**

<b>Client ID Number</b>	<b>Lab ID Number</b>	<b>Reporting Limit (mg/kg)</b>	<b>LEAD CONCENTRATION (mg/kg)</b>
OW-1	EM 2145911	0.64	226
GR-2	EM 2145912	0.87	12,452
SI-3	EM 2145913	0.52	1,728
GY-4	EM 2145914	0.48	2,133
GY-5	EM 2145915	0.48	1,253
GR-6	EM 2145916	0.72	3,425
RD-7	EM 2145917	0.53	12,929
OW-8	EM 2145918	0.62	307
OW-9	EM 2145919	0.71	6,967
OW-10	EM 2145920	0.79	4,015

\* Unless otherwise noted all quality control samples performed within specifications established by the laboratory.

  
Renee A. Cortez

Analyst / Data QA: \_\_\_\_\_



# REILAB Reservoirs Environmental, Inc.

5901 Logan St. Denver, CO 80216 • Ph: 303-964-1986 • Fax: 303-477-4275 • Toll Free: 866-RES-ENV  
After Hours Cell Phone: 720-339-9228

**INVOICE TO: (IF DIFFERENT)**

Company: **SCA Environmental, Inc.**  
Address: 650 Delancey St. Ste. 222  
San Francisco CA 94107

Company: **Christina Codomo**  
Phone:  
Fax:  
Cell/pager:

Project Number and/or P.O. #: **F12766**  
Project Description/Location: **SC VTA, Bldg. F, SJ**

**CONTACT INFORMATION:**

Final Data Deliverable Email Address:

Client sample ID number (Sample ID's must be unique)	REQUESTED ANALYSIS		VALID MATRIX CODES		LAB NOTES:
	PLM - Short report, Point Count, Long report, Qualitative	ORGANICS - METH, TSS RCRA 8, TCLP, Welding Fume, Metals Scan, pH METALS - Analytes) Ph by ICP DUST - Total, Respirable PCM - 7400A, 7400B, OSHA TEM - AHERA, Level II, 7402, ISO, +/- (Air, Bulk or Dust), Quant, Semi-Quant, Micro-vac, ISO-Indirect Preps	Microbiology Viabiles Pathogens: Aerobic Plate Count, Salmonella, E. coli O157:H7, Listeria, S. aureus, Campylobacter, +/- or Quantification E. coli and/or Coliforms: +/- or Quantification State Water (Please Circle One) Yes / No Bacteria, Fungal, +/- or Quantification Mold, Spore Trap or Bulk: +/-, Identification, Quantification, Viable or Non-Viable Other: Bioburden, LAL or Environmental Legionella: +/- or Quantification	Air = A Bulk = B Dust = D Paint = P Soil = S Wipe = W Swab = SW F = Food Drinking Water = DW Waste Water = WW O = Other **ASTM E1792 approved wipe media only**	
1 OW-1	X				
2 GR-2	X				
3 SI-3	X				
4 GY-4	X				
5 GY-5	X				
6 GR-6	X				
7 RD-7	X				
8 OW-8	X				
9 OW-9	X				
10 OW-10	X				

Number of samples received: **10** (Additional samples shall be listed on attached long form.)

NOTE: REI will analyze incoming samples based upon information received and will not be responsible for errors or omissions in calculations resulting from the inaccuracy of original data. By signing client/company representative agrees that submission of the following samples for requested analysis as indicated on this Chain of Custody shall constitute an analytical services agreement with payment terms of NET 30 days, failure to comply with payment terms may result in a 1.5% monthly interest surcharge.

Relinquished By:	Date/Time:	Hand / FedEx / UPS / USPS / Drop Box / Courier	Sample Condition:	On Ice	Sealed	Intact
<i>[Signature]</i>	8/3/20	UPS	Temp. (F°)	Yes / No	Yes / No	Yes / No
Received By:	Date/Time:	Carrier:				
Data Entry Contact	Phone	Email	Fax	Time	Initials	
QA: Contact	Phone	Email	Fax	Time	Initials	





## **Appendix D**

### **PCB Laboratory Reports**



# McC Campbell Analytical, Inc.

*"When Quality Counts"*

## Analytical Report

**WorkOrder:** 1808527

**Report Created for:** SCA Environmental, Inc.

1 Lakeside Drive, Suite 215  
Oakland, CA 94612

**Project Contact:** Dan Leung

**Project P.O.:**

**Project:** F12766; BM SC VTA BLDG F SVY

**Project Received:** 08/13/2018

Analytical Report reviewed & approved for release on 08/16/2018 by:

Heidi Fruhlinger

Project Manager

*The report shall not be reproduced except in full, without the written approval of the laboratory. The analytical results relate only to the items tested. Results reported conform to the most current NELAP standards, where applicable, unless otherwise stated in the case narrative.*







## Glossary of Terms & Qualifier Definitions

**Client:** SCA Environmental, Inc.  
**Project:** F12766; BM SC VTA BLDG F SVY  
**WorkOrder:** 1808527

### Glossary Abbreviation

%D	Serial Dilution Percent Difference
95% Interval	95% Confident Interval
DF	Dilution Factor
DI WET	(DISTLC) Waste Extraction Test using DI water
DISS	Dissolved (direct analysis of 0.45 µm filtered and acidified water sample)
DLT	Dilution Test (Serial Dilution)
DUP	Duplicate
EDL	Estimated Detection Limit
ERS	External reference sample. Second source calibration verification.
ITEF	International Toxicity Equivalence Factor
LCS	Laboratory Control Sample
MB	Method Blank
MB % Rec	% Recovery of Surrogate in Method Blank, if applicable
MDL	Method Detection Limit
ML	Minimum Level of Quantitation
MS	Matrix Spike
MSD	Matrix Spike Duplicate
N/A	Not Applicable
ND	Not detected at or above the indicated MDL or RL
NR	Data Not Reported due to matrix interference or insufficient sample amount.
PDS	Post Digestion Spike
PDSD	Post Digestion Spike Duplicate
PF	Prep Factor
RD	Relative Difference
RL	Reporting Limit (The RL is the lowest calibration standard in a multipoint calibration.)
RPD	Relative Percent Deviation
RRT	Relative Retention Time
SPK Val	Spike Value
SPKRef Val	Spike Reference Value
SPLP	Synthetic Precipitation Leachate Procedure
ST	Sorbent Tube
TCLP	Toxicity Characteristic Leachate Procedure
TEQ	Toxicity Equivalents
WET (STLC)	Waste Extraction Test (Soluble Threshold Limit Concentration)





## Glossary of Terms & Qualifier Definitions

**Client:** SCA Environmental, Inc.  
**Project:** F12766; BM SC VTA BLDG F SVY  
**WorkOrder:** 1808527

### Analytical Qualifiers

- A The reported value is determined using a "single point" calibration by GC-ECD as allowed by the method.
- S Surrogate spike recovery outside accepted recovery limits
- a4 Reporting limits raised due to the sample's matrix prohibiting a full volume extraction.
- c1 Surrogate recovery outside of the control limits due to the dilution of the sample.
- c2 Surrogate recovery outside of the control limits due to matrix interference.
- c9 Internal standard is out of acceptance criteria due to matrix interference therefore values are estimated



## Analytical Report

**Client:** SCA Environmental, Inc.  
**Date Received:** 8/13/18 10:17  
**Date Prepared:** 8/13/18  
**Project:** F12766; BM SC VTA BLDG F SVY

**WorkOrder:** 1808527  
**Extraction Method:** SW3550B/3630C  
**Analytical Method:** SW8082  
**Unit:** mg/kg

### Polychlorinated Biphenyls (PCBs) Aroclors w/ Column Style Clean-up

Client ID	Lab ID	Matrix	Date Collected	Instrument	Batch ID
WL-18	1808527-001A	Solid	08/09/2018	GC23 08151808.D	163162

Analytes	Result	Qualifiers	MDL	RL	DF	Date Analyzed
Aroclor1016	ND		0.51	5.0	10	08/15/2018 16:36
Aroclor1221	ND		1.1	5.0	10	08/15/2018 16:36
Aroclor1232	ND		0.63	5.0	10	08/15/2018 16:36
Aroclor1242	ND		0.67	5.0	10	08/15/2018 16:36
Aroclor1248	ND		0.40	5.0	10	08/15/2018 16:36
Aroclor1254	11	A	0.68	5.0	10	08/15/2018 16:36
Aroclor1260	ND		0.61	5.0	10	08/15/2018 16:36
PCBs, total	11		0.40	5.0	10	08/15/2018 16:36

Surrogates	REC (%)	Qualifiers	Limits	Date Analyzed
Decachlorobiphenyl	33	S	70-130	08/15/2018 16:36

**Analyst(s):** LT **Analytical Comments:** a4,c1

Client ID	Lab ID	Matrix	Date Collected	Instrument	Batch ID
CAULK-20	1808527-003A	Solid	08/09/2018	GC23 08141832.D	163162

Analytes	Result	MDL	RL	DF	Date Analyzed
Aroclor1016	ND	0.051	0.50	1	08/15/2018 00:09
Aroclor1221	ND	0.11	0.50	1	08/15/2018 00:09
Aroclor1232	ND	0.063	0.50	1	08/15/2018 00:09
Aroclor1242	ND	0.067	0.50	1	08/15/2018 00:09
Aroclor1248	ND	0.040	0.50	1	08/15/2018 00:09
Aroclor1254	ND	0.068	0.50	1	08/15/2018 00:09
Aroclor1260	ND	0.061	0.50	1	08/15/2018 00:09
PCBs, total	ND	0.040	0.50	1	08/15/2018 00:09

Surrogates	REC (%)	Qualifiers	Limits	Date Analyzed
Decachlorobiphenyl	163	S	70-130	08/15/2018 00:09

**Analyst(s):** LT **Analytical Comments:** a4,c9,c2



## Quality Control Report

<b>Client:</b>	SCA Environmental, Inc.	<b>WorkOrder:</b>	1808527
<b>Date Prepared:</b>	8/13/18	<b>BatchID:</b>	163162
<b>Date Analyzed:</b>	8/14/18	<b>Extraction Method:</b>	SW3550B/3630C
<b>Instrument:</b>	GC20, GC23	<b>Analytical Method:</b>	SW8082
<b>Matrix:</b>	Soil	<b>Unit:</b>	mg/kg
<b>Project:</b>	F12766; BM SC VTA BLDG F SVY	<b>Sample ID:</b>	MB/LCS/LCSD-163162

### QC Summary Report for SW8082 w/ Column Clean-up

Analyte	MB Result	MDL	RL	SPK Val	MB SS %REC	MB SS Limits
Aroclor1016	ND	0.0051	0.050	-	-	-
Aroclor1221	ND	0.011	0.050	-	-	-
Aroclor1232	ND	0.0063	0.050	-	-	-
Aroclor1242	ND	0.0067	0.050	-	-	-
Aroclor1248	ND	0.0040	0.050	-	-	-
Aroclor1254	ND	0.0068	0.050	-	-	-
Aroclor1260	ND	0.0061	0.050	-	-	-
PCBs, total	ND	0.0040	0.050	-	-	-

#### Surrogate Recovery

Decachlorobiphenyl	0.0526		0.050	105	57-145
--------------------	--------	--	-------	-----	--------

Analyte	LCS Result	LCSD Result	SPK Val	LCS %REC	LCSD %REC	LCS/LCSD Limits	RPD	RPD Limit
Aroclor1016	0.172	0.182	0.15	114	122	61-124	6.08	20
Aroclor1260	0.156	0.163	0.15	104	109	53-172	4.33	20

#### Surrogate Recovery

Decachlorobiphenyl	0.0534	0.0548	0.050	107	110	57-145	2.69	20
--------------------	--------	--------	-------	-----	-----	--------	------	----



# CHAIN-OF-CUSTODY RECORD

WorkOrder: 1808527 ClientCode: SCAO

WaterTrax     WriteOn     EDF     Excel     EQuIS     Email     HardCopy     ThirdParty     J-flag  
 Detection Summary     Dry-Weight

**Report to:** Dan Leung    Accounts Payable    Requested TATs: 10 days;  
 SCA Environmental, Inc.    SCA Environmental, Inc.    5 days;  
 1 Lakeside Drive, Suite 215    1 Lakeside Drive, Suite 215    Date Received: 08/13/2018  
 Oakland, CA 94612    Oakland, CA 94612    Date Logged: 08/13/2018  
 415-378-4188    FAX: (510) 839-6200    emuise@sca-ic.com; pgervasio@scaeh

Lab ID	Client ID	Matrix	Collection Date	Hold	Requested Tests (See legend below)													
					1	2	3	4	5	6	7	8	9	10	11	12		
1808527-001	WL-18	Solid	8/9/2018 00:00	<input type="checkbox"/>	A													
1808527-002	CAULK-19	Solid	8/9/2018 00:00	<input type="checkbox"/>	A	A	A											
1808527-003	CAULK-20	Solid	8/9/2018 00:00	<input type="checkbox"/>	A	A	A											

**Test Legend:**

1	8082_PCB_ESL_S [J]	2	8082_PCB_SG_S	3	8082_PCB_SG_Solid [J]	4	8082_Soxhlet_SG_Solid
5		6		7		8	
9		10		11		12	

Prepared by: Jena Alfaro

**Comments:** 8082\_PCB Soxhlet\_SG extraction added 8/17/2018 RUSH TAT

NOTE: Soil samples are discarded 60 days after results are reported unless other arrangements are made (Water samples are 30 days). Hazardous samples will be returned to client or disposed of at client expense.





**McC Campbell Analytical, Inc.**  
 "When Quality Counts"

1534 Willow Pass Road, Pittsburg, CA 94565-1701  
 Toll Free Telephone: (877) 252-9262 / Fax: (925) 252-9269  
 http://www.mcccampbell.com / E-mail: main@mcccampbell.com

### WORK ORDER SUMMARY

**Client Name:** SCA ENVIRONMENTAL, INC. **Project:** F12766; BM SC VTA BLDG F SVY **Work Order:** 1808527  
**Client Contact:** Dan Leung **Comments:** 8082 PCB Soxhlet SG extraction added 8/17/2018 RUSH TAT **QC Level:** LEVEL 2  
**Contact's Email:** dleung@sca-enviro.com; labreports99@gmail.com **Date Logged:** 8/13/2018

WaterTrax  WriteOn  EDF  Excel  Fax  Email  HardCopy  ThirdParty  J-flag

Lab ID	Client ID	Matrix	Test Name	Containers /Composites	Bottle & Preservative	De-chlorinated	Collection Date & Time	TAT	Sediment Content	Hold	SubOut
1808527-001A	WL-18	Solid	SW8082 (PCBs w/ Column Style Clean-up) SW8082 (PCBs Only)	1	Small White Plastic Container	<input type="checkbox"/>	8/9/2018	5 days		<input type="checkbox"/>	
1808527-002A	CAULK-19	Solid	SW8082 (PCBs w/ Soxhlet Extraction & SG CU) SW8082 (PCBs w/ Column Style Clean-up) SW8082 (PCBs Only)	1	Small White Plastic Container	<input type="checkbox"/>	8/9/2018	5 days		<input checked="" type="checkbox"/>	
1808527-003A	CAULK-20	Solid	SW8082 (PCBs w/ Column Style Clean-up) SW8082 (PCBs Only)	1	Small White Plastic Container	<input type="checkbox"/>	8/9/2018	5 days		<input type="checkbox"/>	

**NOTES:** - STLC and TCLP extractions require 2 days to complete; therefore, all TATs begin after the extraction is completed (i.e., One-day TAT yields results in 3 days from sample submission).  
 - MAI assumes that all material present in the provided sampling container is considered part of the sample - MAI does not exclude any material from the sample prior to sample preparation unless requested in writing by the client.









### Sample Receipt Checklist

Client Name: SCA Environmental, Inc.  
Project: F12766; BM SC VTA BLDG F SVY  
WorkOrder No: 1808527 Matrix:  
Carrier: UPS

Date and Time Received 8/13/2018 10:17  
Date Logged: 8/13/2018  
Received by: Jena Alfaro  
Logged by: Jena Alfaro

#### Chain of Custody (COC) Information

Chain of custody present? Yes  No   
Chain of custody signed when relinquished and received? Yes  No   
Chain of custody agrees with sample labels? Yes  No   
Sample IDs noted by Client on COC? Yes  No   
Date and Time of collection noted by Client on COC? Yes  No   
Sampler's name noted on COC? Yes  No   
COC agrees with Quote? Yes  No  NA

#### Sample Receipt Information

Custody seals intact on shipping container/cooler? Yes  No  NA   
Shipping container/cooler in good condition? Yes  No   
Samples in proper containers/bottles? Yes  No   
Sample containers intact? Yes  No   
Sufficient sample volume for indicated test? Yes  No

#### Sample Preservation and Hold Time (HT) Information

All samples received within holding time? Yes  No  NA   
Samples Received on Ice? Yes  No   
Sample/Temp Blank temperature Temp: NA   
Water - VOA vials have zero headspace / no bubbles? Yes  No  NA   
Sample labels checked for correct preservation? Yes  No   
pH acceptable upon receipt (Metal: <2; 522: <4; 218.7: >8)? Yes  No  NA   
UCMR Samples:  
pH tested and acceptable upon receipt (200.8: ≤2; 525.3: ≤4; 530: ≤7; 541: <3; 544: <6.5 & 7.5)? Yes  No  NA   
Free Chlorine tested and acceptable upon receipt (<0.1mg/L)? Yes  No  NA

Comments: Method SW8082 (PCBs Only) was received with temperature condition not met.





McC Campbell Analytical, Inc.

"When Quality Counts"

## Analytical Report

**WorkOrder:** 1808527 A

**Report Created for:** SCA Environmental, Inc.

1 Lakeside Drive, Suite 215  
Oakland, CA 94612

**Project Contact:** Dan Leung

**Project P.O.:**

**Project:** F12766; BM SC VTA BLDG F SVY

**Project Received:** 08/13/2018

Analytical Report reviewed & approved for release on 08/21/2018 by:

Heidi Fruhlinger  
Project Manager

*The report shall not be reproduced except in full, without the written approval of the laboratory. The analytical results relate only to the items tested. Results reported conform to the most current NELAP standards, where applicable, unless otherwise stated in the case narrative.*





## Glossary of Terms & Qualifier Definitions

**Client:** SCA Environmental, Inc.  
**Project:** F12766; BM SC VTA BLDG F SVY  
**WorkOrder:** 1808527 A

### Glossary Abbreviation

%D	Serial Dilution Percent Difference
95% Interval	95% Confident Interval
DF	Dilution Factor
DI WET	(DISTLC) Waste Extraction Test using DI water
DISS	Dissolved (direct analysis of 0.45 µm filtered and acidified water sample)
DLT	Dilution Test (Serial Dilution)
DUP	Duplicate
EDL	Estimated Detection Limit
ERS	External reference sample. Second source calibration verification.
ITEF	International Toxicity Equivalence Factor
LCS	Laboratory Control Sample
MB	Method Blank
MB % Rec	% Recovery of Surrogate in Method Blank, if applicable
MDL	Method Detection Limit
ML	Minimum Level of Quantitation
MS	Matrix Spike
MSD	Matrix Spike Duplicate
N/A	Not Applicable
ND	Not detected at or above the indicated MDL or RL
NR	Data Not Reported due to matrix interference or insufficient sample amount.
PDS	Post Digestion Spike
PDSD	Post Digestion Spike Duplicate
PF	Prep Factor
RD	Relative Difference
RL	Reporting Limit (The RL is the lowest calibration standard in a multipoint calibration.)
RPD	Relative Percent Deviation
RRT	Relative Retention Time
SPK Val	Spike Value
SPKRef Val	Spike Reference Value
SPLP	Synthetic Precipitation Leachate Procedure
ST	Sorbent Tube
TCLP	Toxicity Characteristic Leachate Procedure
TEQ	Toxicity Equivalents
WET (STLC)	Waste Extraction Test (Soluble Threshold Limit Concentration)

### Analytical Qualifiers

a4 Reporting limits raised due to the sample's matrix prohibiting a full volume extraction.



McC Campbell Analytical, Inc.

"When Quality Counts"

1534 Willow Pass Road, Pittsburg, CA 94565-1701  
Toll Free Telephone: (877) 252-9262 / Fax: (925) 252-9269  
http://www.mcccampbell.com / E-mail: main@mcccampbell.com

# Analytical Report

**Client:** SCA Environmental, Inc.  
**Date Received:** 8/13/18 10:17  
**Date Prepared:** 8/20/18  
**Project:** F12766; BM SC VTA BLDG F SVY

**WorkOrder:** 1808527  
**Extraction Method:** SW3540C/3630C  
**Analytical Method:** SW8082  
**Unit:** mg/kg

## Polychlorinated Biphenyls (PCBs) Aroclors w/ Soxhlet Extraction and Silica Gel Clean-up

Client ID	Lab ID	Matrix	Date Collected	Instrument	Batch ID
CAULK-19	1808527-002A	Solid	08/09/2018	GC40 08211805.d	163580

Analytes	Result	RL	DF	Date Analyzed
Aroclor1016	ND	0.50	1	08/21/2018 14:29
Aroclor1221	ND	0.50	1	08/21/2018 14:29
Aroclor1232	ND	0.50	1	08/21/2018 14:29
Aroclor1242	ND	0.50	1	08/21/2018 14:29
Aroclor1248	ND	0.50	1	08/21/2018 14:29
Aroclor1254	ND	0.50	1	08/21/2018 14:29
Aroclor1260	ND	0.50	1	08/21/2018 14:29
PCBs, total	ND	0.50	1	08/21/2018 14:29

Surrogates	REC (%)	Limits	Date Analyzed
Decachlorobiphenyl	81	70-130	08/21/2018 14:29

**Analyst(s):** LT

**Analytical Comments:** a4





# Quality Control Report

Client: SCA Environmental, Inc.

WorkOrder: 1808527

Date Prepared: 8/20/18

BatchID: 163580

Date Analyzed: 8/20/18

Extraction Method: SW3540C/3630C

Instrument: GC23

Analytical Method: SW8082

Matrix: Solid

Unit: mg/kg

Project: F12766; BM SC VTA BLDG F SVY

Sample ID: MB/LCS/LCSD-163580

## QC Summary for SW8082

Analyte	MB Result	RL	SPK Val	MB SS %REC	MB SS Limits
Aroclor1016	ND	0.050	-	-	-
Aroclor1221	ND	0.050	-	-	-
Aroclor1232	ND	0.050	-	-	-
Aroclor1242	ND	0.050	-	-	-
Aroclor1248	ND	0.050	-	-	-
Aroclor1254	ND	0.050	-	-	-
Aroclor1260	ND	0.050	-	-	-
PCBs, total	ND	0.050	-	-	-

### Surrogate Recovery

Decachlorobiphenyl	0.0348	0.050	70	70-130
--------------------	--------	-------	----	--------

Analyte	LCS Result	LCSD Result	SPK Val	LCS %REC	LCSD %REC	LCS/LCSD Limits	RPD	RPD Limit
Aroclor1016	0.118	0.130	0.15	79	86	70-130	9.47	20
Aroclor1260	0.126	0.132	0.15	84	88	70-130	4.11	20

### Surrogate Recovery

Decachlorobiphenyl	0.0387	0.0379	0.050	77	76	70-130	2.05	20
--------------------	--------	--------	-------	----	----	--------	------	----

# CHAIN-OF-CUSTODY RECORD

WorkOrder: 1808527 A ClientCode: SCAO

WaterTrax     WriteOn     EDF     Excel     Fax     Email     HardCopy     ThirdParty     J-flag  
 Detection Summary     Dry-Weight

**Report to:** Dan Leung    Accounts Payable    Requested TAT: 10 days;  
 SCA Environmental, Inc.    SCA Environmental, Inc.    Date Received: 08/13/2018  
 1 Lakeside Drive, Suite 215    1 Lakeside Drive, Suite 215    Date Logged: 08/13/2018  
 Oakland, CA 94612    Oakland, CA 94612    Date Add-On: 08/17/2018  
 415-378-4188    FAX: (510) 839- 6200    emuise@sca-ic.com; pgevasio@scaeh

Lab ID	Client ID	Matrix	Collection Date	Hold	1	2	3	4	5	6	7	8	9	10	11	12
1808527-002	CAULK-19	Solid	8/9/2018 00:00	<input type="checkbox"/>	A											

Requested Tests (See legend below)

**Test Legend:**

1	8082_Soxhlet_SG_Solid	3	4
5		7	8
9		11	12

Prepared by: Jena Alfaro  
 Add-On Prepared By: Jena Alfaro

Comments: 8082\_PCB Soxhlet\_SG extraction added 8/17/2018 RUSH TAT

NOTE: Soil samples are discarded 60 days after results are reported unless other arrangements are made (Water samples are 30 days).  
 Hazardous samples will be returned to client or disposed of at client expense.



**McC Campbell Analytical, Inc.**

*"When Quality Counts"*

1534 Willow Pass Road, Pittsburg, CA 94565-1701  
Toll Free Telephone: (877) 252-9262 / Fax: (925) 252-9269  
http://www.mcccampbell.com / E-mail: [main@mcccampbell.com](mailto:main@mcccampbell.com)

### WORK ORDER SUMMARY

**Client Name:** SCA ENVIRONMENTAL, INC.  
**Client Contact:** Dan Leung  
**Contact's Email:** [dleung@sca-enviro.com](mailto:dleung@sca-enviro.com); [labreports99@gmail.com](mailto:labreports99@gmail.com)

**Project:** F12766; BM SC VTA BLDG F SVY

**Work Order:** 1808527  
**QC Level:** LEVEL 2  
**Date Logged:** 8/13/2018  
**Date Add-On:** 8/17/2018

**Comments:** 8082 PCB Soxhlet SG extraction added 8/17/2018 RUSH TAT

Lab ID	Client ID	Matrix	Test Name	Containers /Composites	Bottle & Preservative	Collection Date & Time	TAT	Sediment Content	Hold SubOut
1808527-002A	CAULK-19	Solid	SW8082 (PCBs w/ Soxhlet Extraction & SG CU)	1	Small White Plastic Container	8/9/2018	5 days		<input type="checkbox"/>

**NOTES:** - STLC and TCLP extractions require 2 days to complete; therefore, all TATs begin after the extraction is completed (i.e., One-day TAT yields results in 3 days from sample submission).

- MAI assumes that all material present in the provided sampling container is considered part of the sample - MAI does not exclude any material from the sample prior to sample preparation unless requested in writing by the client.









# McC Campbell Analytical, Inc.

"When Quality Counts"

## Analytical Report

**WorkOrder:** 1809776

**Report Created for:** SCA Environmental, Inc.

1 Lakeside Drive, Suite 215  
Oakland, CA 94612

**Project Contact:** Dan Leung

**Project P.O.:**

**Project:** F12766.01; SC VTA BLR SVY

**Project Received:** 09/19/2018

Analytical Report reviewed & approved for release on 09/26/2018 by:

Yen Cao

Project Manager

*The report shall not be reproduced except in full, without the written approval of the laboratory. The analytical results relate only to the items tested. Results reported conform to the most current NELAP standards, where applicable, unless otherwise stated in the case narrative.*





## Glossary of Terms & Qualifier Definitions

**Client:** SCA Environmental, Inc.  
**Project:** F12766.01; SC VTA BLR SVY  
**WorkOrder:** 1809776

### Glossary Abbreviation

%D	Serial Dilution Percent Difference
95% Interval	95% Confident Interval
DF	Dilution Factor
DI WET	(DISTLC) Waste Extraction Test using DI water
DISS	Dissolved (direct analysis of 0.45 µm filtered and acidified water sample)
DLT	Dilution Test (Serial Dilution)
DUP	Duplicate
EDL	Estimated Detection Limit
ERS	External reference sample. Second source calibration verification.
ITEF	International Toxicity Equivalence Factor
LCS	Laboratory Control Sample
MB	Method Blank
MB % Rec	% Recovery of Surrogate in Method Blank, if applicable
MDL	Method Detection Limit
ML	Minimum Level of Quantitation
MS	Matrix Spike
MSD	Matrix Spike Duplicate
N/A	Not Applicable
ND	Not detected at or above the indicated MDL or RL
NR	Data Not Reported due to matrix interference or insufficient sample amount.
PDS	Post Digestion Spike
PDSD	Post Digestion Spike Duplicate
PF	Prep Factor
RD	Relative Difference
RL	Reporting Limit (The RL is the lowest calibration standard in a multipoint calibration.)
RPD	Relative Percent Deviation
RRT	Relative Retention Time
SPK Val	Spike Value
SPKRef Val	Spike Reference Value
SPLP	Synthetic Precipitation Leachate Procedure
ST	Sorbent Tube
TCLP	Toxicity Characteristic Leachate Procedure
TEQ	Toxicity Equivalents
WET (STLC)	Waste Extraction Test (Soluble Threshold Limit Concentration)

### Analytical Qualifiers

A The reported value is determined using a "single point" calibration by GC-ECD as allowed by the method.



# Analytical Report

**Client:** SCA Environmental, Inc.  
**Date Received:** 9/19/18 13:18  
**Date Prepared:** 9/20/18  
**Project:** F12766.01; SC VTA BLR SVY

**WorkOrder:** 1809776  
**Extraction Method:** SW3540C/3630C  
**Analytical Method:** SW8082  
**Unit:** mg/kg

## Polychlorinated Biphenyls (PCBs) Aroclors w/ Soxhlet Extraction and Silica Gel Clean-up

Client ID	Lab ID	Matrix	Date Collected	Instrument	Batch ID
EXPJT-21	1809776-001A	Solid	09/19/2018	GC23 09211807.D	165308

Analytes	Result	Qualifiers	RL	DF	Date Analyzed
Aroclor1016	ND		0.050	1	09/21/2018 15:33
Aroclor1221	ND		0.050	1	09/21/2018 15:33
Aroclor1232	ND		0.050	1	09/21/2018 15:33
Aroclor1242	ND		0.050	1	09/21/2018 15:33
Aroclor1248	ND		0.050	1	09/21/2018 15:33
Aroclor1254	0.28	A	0.050	1	09/21/2018 15:33
Aroclor1260	ND		0.050	1	09/21/2018 15:33
PCBs, total	0.28		0.050	1	09/21/2018 15:33

Surrogates	REC (%)	Limits	Date Analyzed
Decachlorobiphenyl	101	70-130	09/21/2018 15:33

**Analyst(s):** LT





## Quality Control Report

<b>Client:</b> SCA Environmental, Inc.	<b>WorkOrder:</b> 1809776
<b>Date Prepared:</b> 9/20/18	<b>BatchID:</b> 165308
<b>Date Analyzed:</b> 9/25/18	<b>Extraction Method:</b> SW3540C/3630C
<b>Instrument:</b> GC23	<b>Analytical Method:</b> SW8082
<b>Matrix:</b> Solid	<b>Unit:</b> mg/kg
<b>Project:</b> F12766.01; SC VTA BLR SVY	<b>Sample ID:</b> MB/LCS/LCSD-165308

### QC Summary for SW8082

Analyte	MB Result	RL	SPK Val	MB SS %REC	MB SS Limits
Aroclor1016	ND	0.050	-	-	-
Aroclor1221	ND	0.050	-	-	-
Aroclor1232	ND	0.050	-	-	-
Aroclor1242	ND	0.050	-	-	-
Aroclor1248	ND	0.050	-	-	-
Aroclor1254	ND	0.050	-	-	-
Aroclor1260	ND	0.050	-	-	-
PCBs, total	ND	0.050	-	-	-

**Surrogate Recovery**

Decachlorobiphenyl	0.0469	0.050	94	70-130
--------------------	--------	-------	----	--------

Analyte	LCS Result	LCSD Result	SPK Val	LCS %REC	LCSD %REC	LCS/LCSD Limits	RPD	RPD Limit
Aroclor1016	0.138	0.135	0.15	92	90	70-130	2.08	20
Aroclor1260	0.141	0.143	0.15	94	95	70-130	1.79	20

**Surrogate Recovery**

Decachlorobiphenyl	0.0421	0.0440	0.050	84	88	70-130	4.56	20
--------------------	--------	--------	-------	----	----	--------	------	----





McC Campbell Analytical, Inc.

"When Quality Counts"

1534 Willow Pass Road, Pittsburg, CA 94565-1701  
Toll Free Telephone: (877) 252-9262 / Fax: (925) 252-9269  
http://www.mccampbell.com / E-mail: main@mccampbell.com

### WORK ORDER SUMMARY

Client Name: SCA ENVIRONMENTAL, INC.      Project: F12766.01; SC VTA BLR SVY      Work Order: 1809776  
 Client Contact: Dan Leung      Comments:      QC Level: LEVEL 2  
 Contact's Email: dleung@sca-enviro.com; labreports99@gmail.com      Date Logged: 9/19/2018

WaterTrax     WriteOn     EDF     Excel     Fax     Email     HardCopy     ThirdParty     J-flag

Lab ID	Client ID	Matrix	Test Name	Containers /Composites	Bottle & Preservative	De-chlorinated	Collection Date & Time	TAT	Sediment Hold Content	SubOut
1809776-001A	EXPT-21	Solid	SW8082 (PCBs w/ Soxhlet Extraction & SG CU)	1	2OZ PJ	<input type="checkbox"/>	9/19/2018	3 days	<input type="checkbox"/>	

**NOTES:** - STLC and TCLP extractions require 2 days to complete; therefore, all TATs begin after the extraction is completed (i.e., One-day TAT yields results in 3 days from sample submission).  
 - MAI assumes that all material present in the provided sampling container is considered part of the sample - MAI does not exclude any material from the sample prior to sample preparation unless requested in writing by the client.









## Sample Receipt Checklist

Client Name: **SCA Environmental, Inc.**  
 Project: **F12766.01; SC VTA BLR SVY**  
 WorkOrder No: **1809776** Matrix: Solid  
 Carrier: Client Drop-In

Date and Time Received: **9/19/2018 13:18**  
 Date Logged: **9/19/2018**  
 Received by: **Agustina Venegas**  
 Logged by: **Agustina Venegas**

### Chain of Custody (COC) Information

Chain of custody present?	Yes <input checked="" type="checkbox"/>	No <input type="checkbox"/>	
Chain of custody signed when relinquished and received?	Yes <input checked="" type="checkbox"/>	No <input type="checkbox"/>	
Chain of custody agrees with sample labels?	Yes <input checked="" type="checkbox"/>	No <input type="checkbox"/>	
Sample IDs noted by Client on COC?	Yes <input checked="" type="checkbox"/>	No <input type="checkbox"/>	
Date and Time of collection noted by Client on COC?	Yes <input checked="" type="checkbox"/>	No <input type="checkbox"/>	
Sampler's name noted on COC?	Yes <input checked="" type="checkbox"/>	No <input type="checkbox"/>	
COC agrees with Quote?	Yes <input type="checkbox"/>	No <input type="checkbox"/>	NA <input checked="" type="checkbox"/>

### Sample Receipt Information

Custody seals intact on shipping container/cooler?	Yes <input type="checkbox"/>	No <input type="checkbox"/>	NA <input checked="" type="checkbox"/>
Shipping container/cooler in good condition?	Yes <input checked="" type="checkbox"/>	No <input type="checkbox"/>	
Samples in proper containers/bottles?	Yes <input checked="" type="checkbox"/>	No <input type="checkbox"/>	
Sample containers intact?	Yes <input checked="" type="checkbox"/>	No <input type="checkbox"/>	
Sufficient sample volume for indicated test?	Yes <input checked="" type="checkbox"/>	No <input type="checkbox"/>	

### Sample Preservation and Hold Time (HT) Information

All samples received within holding time?	Yes <input checked="" type="checkbox"/>	No <input type="checkbox"/>	NA <input type="checkbox"/>
Samples Received on Ice?	Yes <input type="checkbox"/>	No <input checked="" type="checkbox"/>	
Sample/Temp Blank temperature		Temp:	NA <input checked="" type="checkbox"/>
Water - VOA vials have zero headspace / no bubbles?	Yes <input type="checkbox"/>	No <input type="checkbox"/>	NA <input checked="" type="checkbox"/>
Sample labels checked for correct preservation?	Yes <input checked="" type="checkbox"/>	No <input type="checkbox"/>	
pH acceptable upon receipt (Metal: <2; 522: <4; 218.7: >8)?	Yes <input type="checkbox"/>	No <input type="checkbox"/>	NA <input checked="" type="checkbox"/>
<u>UCMR Samples:</u>			
pH tested and acceptable upon receipt (200.8: ≤2; 525.3: ≤4; 530: ≤7; 541: <3; 544: <6.5 & 7.5)?	Yes <input type="checkbox"/>	No <input type="checkbox"/>	NA <input checked="" type="checkbox"/>
Free Chlorine tested and acceptable upon receipt (<0.1mg/L)?	Yes <input type="checkbox"/>	No <input type="checkbox"/>	NA <input checked="" type="checkbox"/>

-----  
 Comments:

## **Appendix E**

### **Sample Photos September 19, 2018**



An aerial photograph showing a network of roads and paths in a rural, hilly area. The terrain is a mix of brown and green, suggesting a mix of dry and vegetated land. A prominent road runs diagonally from the upper left towards the lower right. Other smaller roads and paths branch off from this main road. The overall scene is a top-down view of a road layout in a natural setting.

EXPJT-21



CONC-22





CONC-23







CONC-24

**APPENDIX B -SITE PHOTOGRAPHS**





Photograph 1: Exterior Dampers



Photograph 2: Exterior Dampers: Exterior Samples WL-18-2 & WL-18-3

SCVTA- Cerone Bus Yard  
Bldg. F Hazardous Materials  
Survey

 **BURNS  
& MCDONNELL**

Photographs  
July/August 2018  
Bldg. F

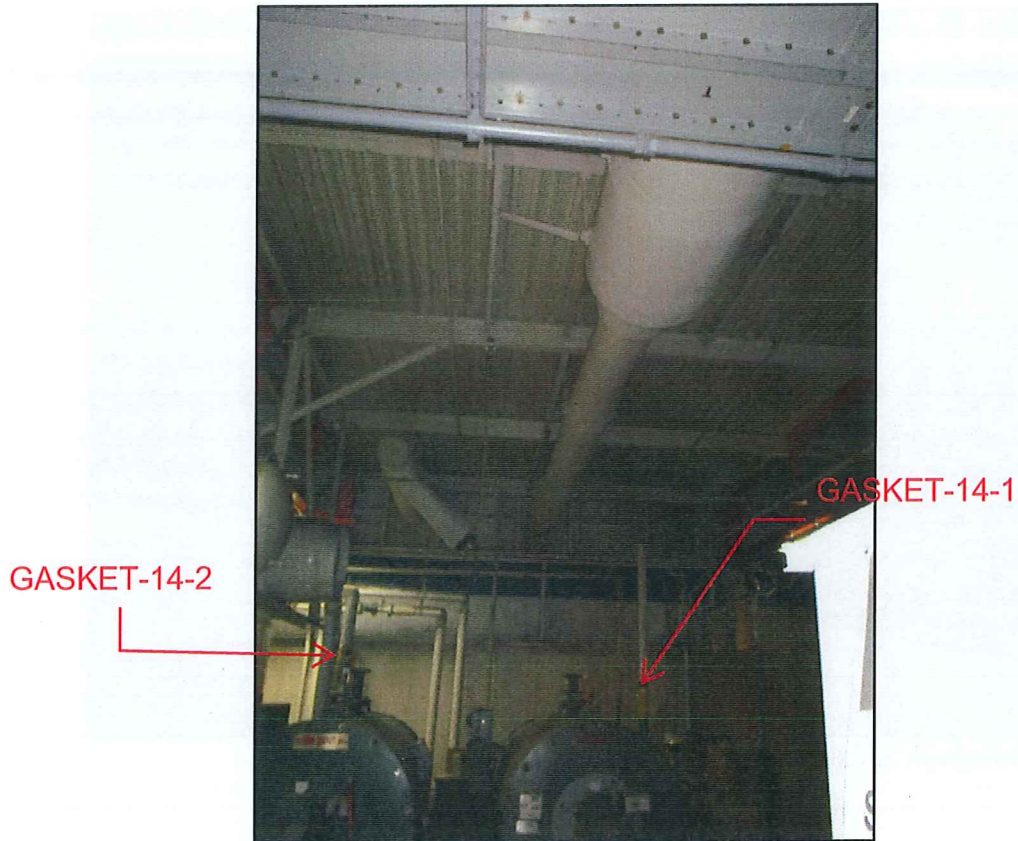

Photograph 3: Decommissioned Boilers- Heating Water Pipes



Photograph 4: Boiler Insulation Sampling

SCVTA- Cerone Bus Yard  
Bldg. F Hazardous Materials  
Survey



Photographs  
July/August 2018  
Bldg. F



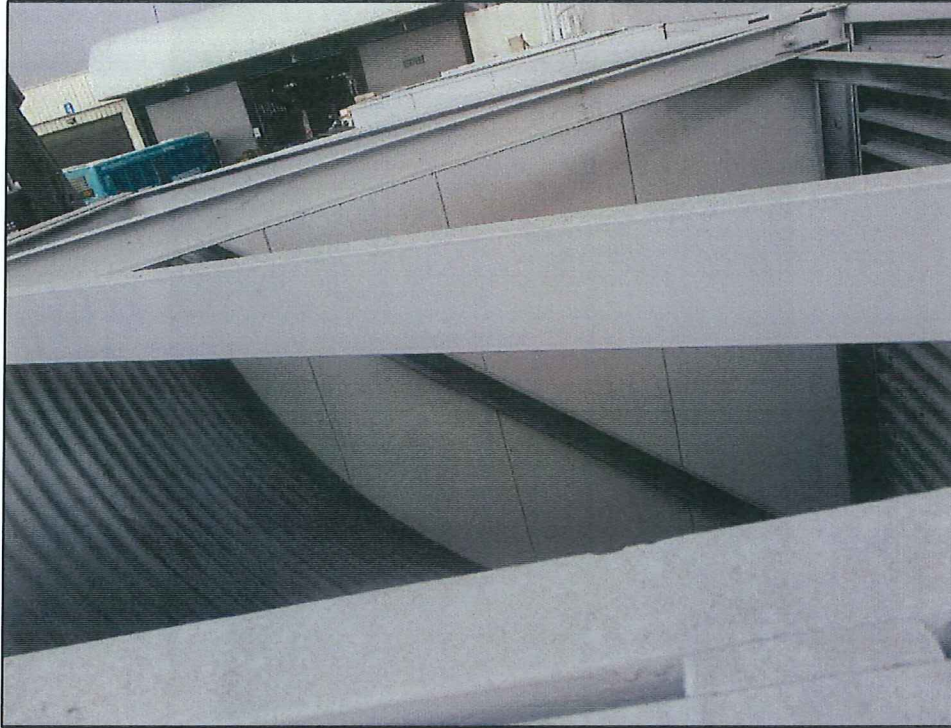

Photograph 5: Exterior Dampers: Interior of Damper

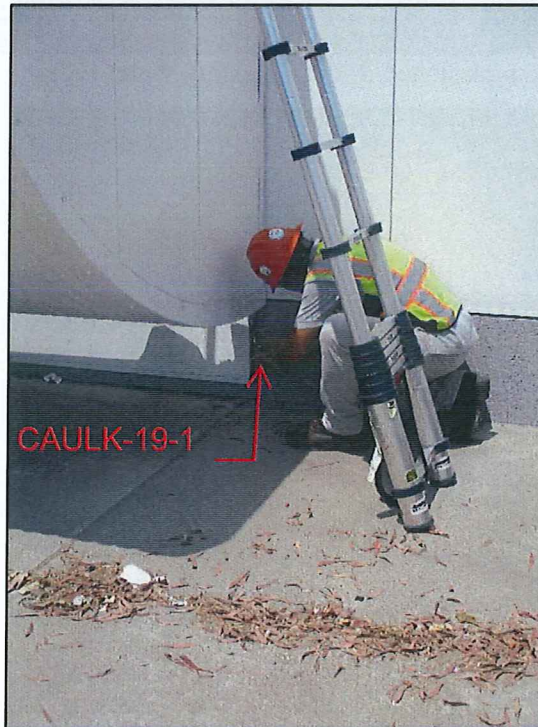

Photograph 6: Exterior Dampers: Exterior Samples Caulk-19

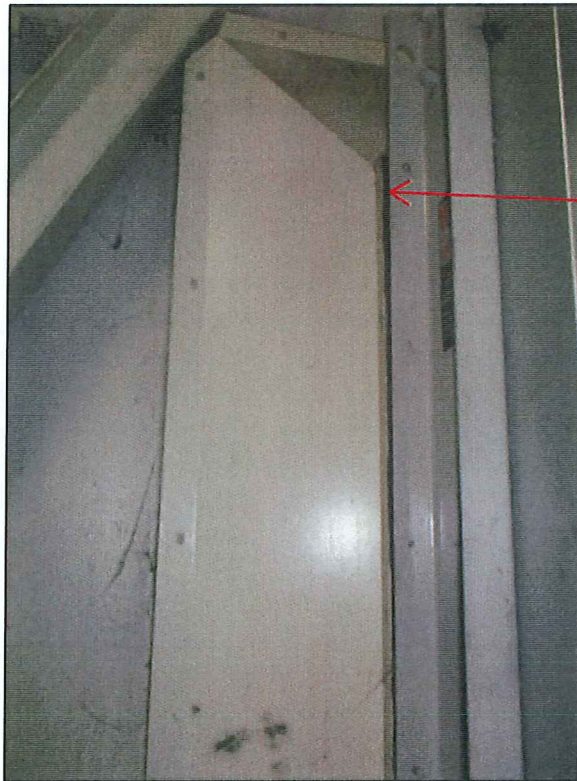

Photograph 7: Caulk -20



Photograph 8: Boiler Insulation Sampling

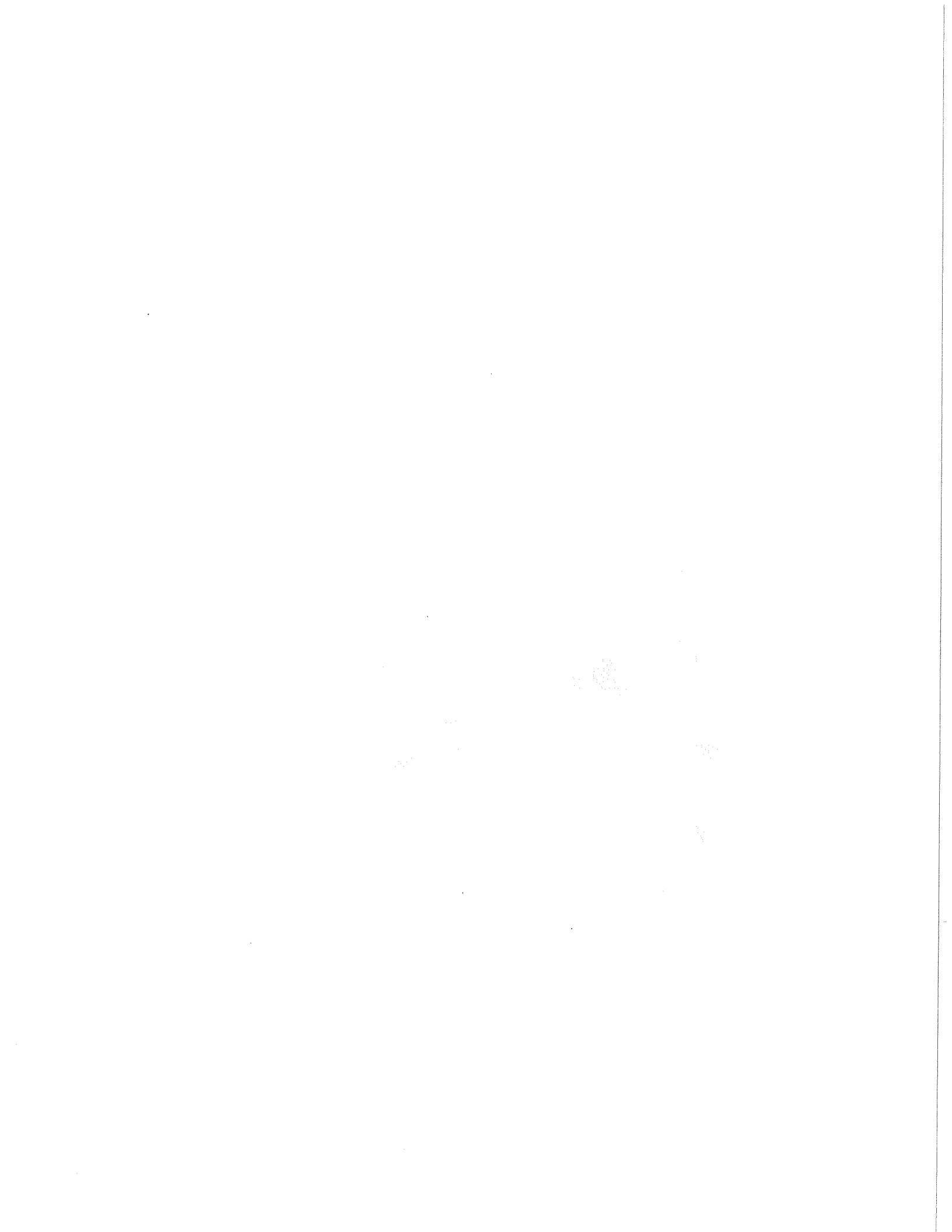





Photograph 9: Expansion Tanks/Piping



Photograph 10: Expansion Tanks/Brackets

SCVTA- Cerone Bus Yard  
Bldg. F Hazardous Materials  
Survey

 **BURNS  
MCDONNELL**

Photographs  
July/August 2018  
Bldg. F



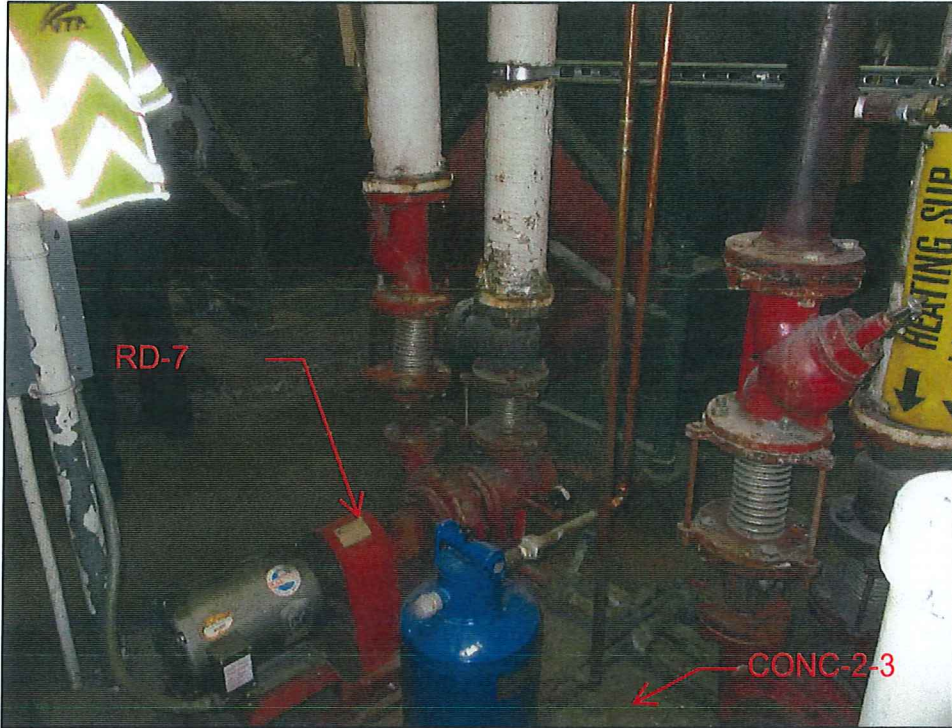

Photograph 11: Red Paint on Boiler Pumps

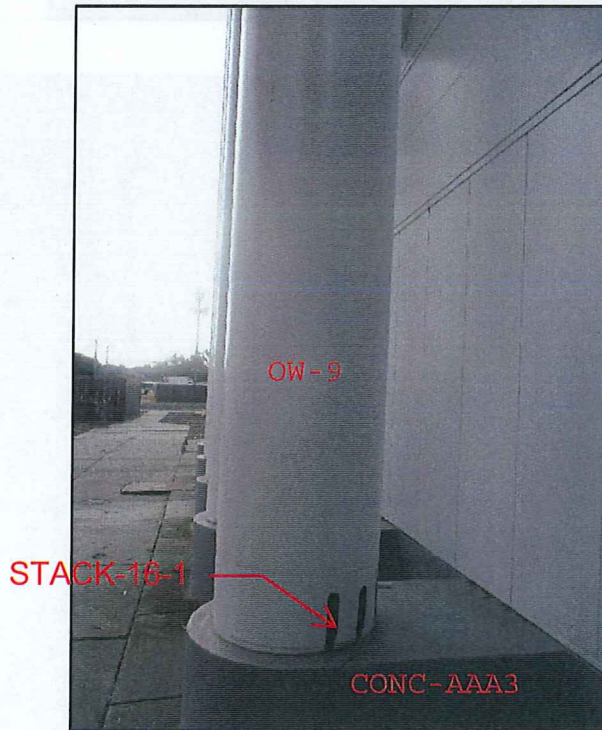

Photograph 12: Boiler Outside Stack, Insulation



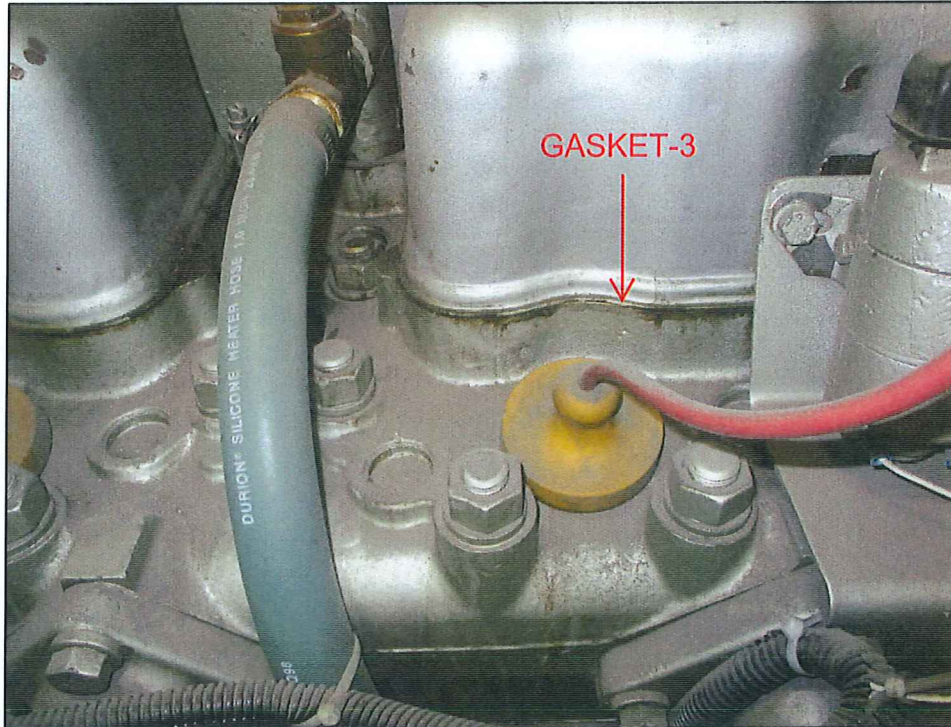
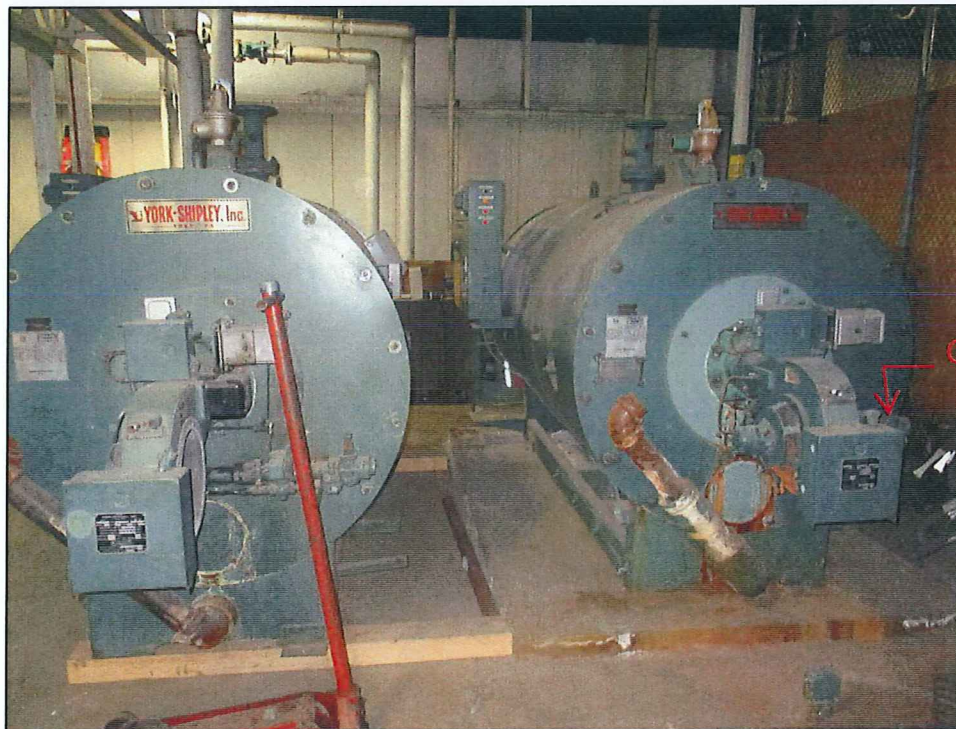
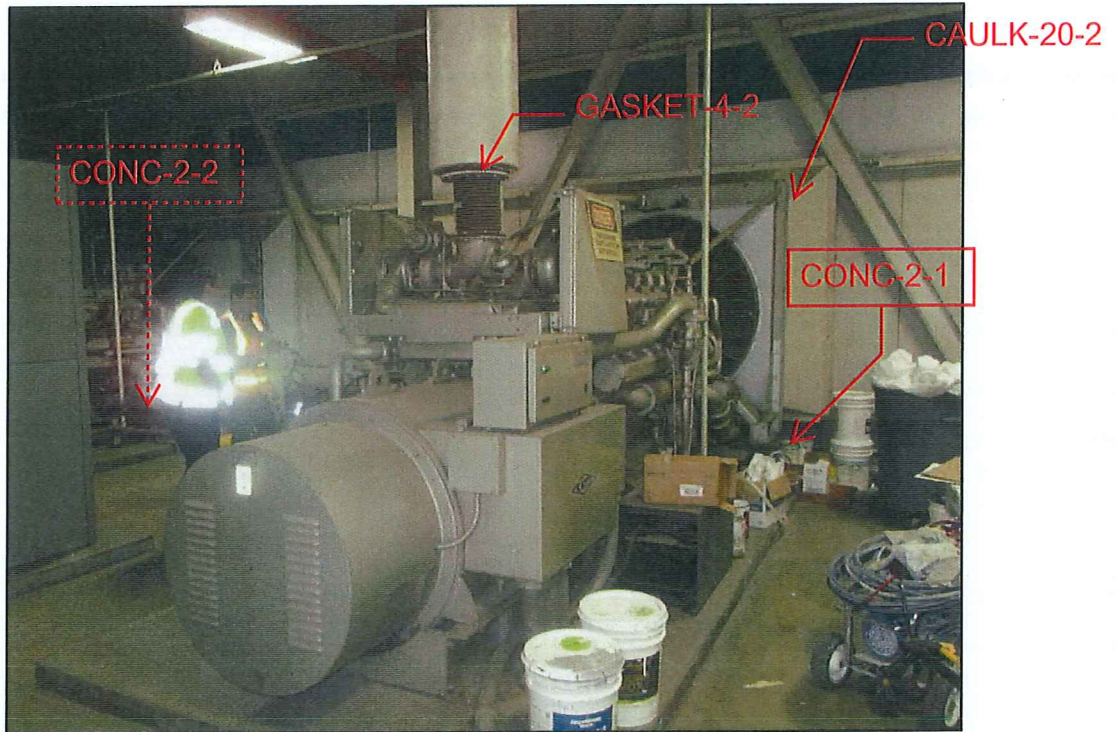

Photo 13: Generator Exhaust Manifolds



Photograph 14: Gasket-17: on Fan Assemblies of Boilers





Photograph 15: East Generator-with Exhaust Fan Assembly

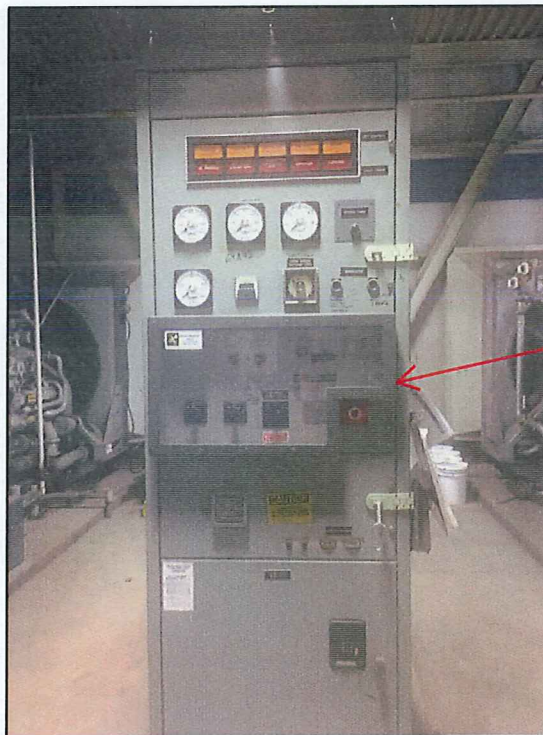

EL-AAA1/  
EL-AAA2

Photograph 16: Generator Control Panel





Photo 17: Expansion Joints Caulking



Photograph 18: Boiler Gray Concrete Pads.





CONC-22

Photograph 19: Gray Concrete Pads- Diesel Generators

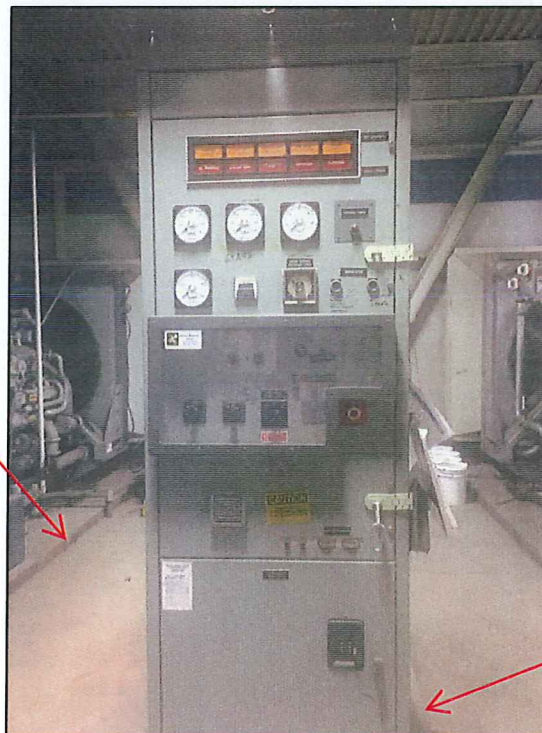

CONC-22

CONC-23

Photograph 20: Gray Concrete Pad: Electrical Equipment

**APPENDIX P**  
**VTA CONTRACT C19010 REFERENCE DRAWINGS**

VTA Contract C19010 Reference drawings are provided in the following pages.



*[This Page Intentionally Left Blank]*

**CONTRACT C19010**

# **CERONE DIVISION EMERGENCY GENERATOR REPLACEMENT**

**Volume 3 – CONTRACT DRAWINGS / PLANS**

The following are selected contract drawings from VTA's C19010 contract.

These drawings do not represent the complete C19010 contract documents and are subject to revision without notice. The information is accurate only as of the date indicated thereon. To receive additional or updated information, Contractor must submit a formal Request For Information (RFI) via the C19123 Contract.

These drawings are provided for reference information only, to provide the C19123 Contractor with general information regarding the scope of work, and area of work, for the C19010 contract. The C19010 contractor may, or may not, be mobilized at the time of construction for the C19123 Contract. C19123 Contractor is reminded of the requirements contained in Contract Section 6.11 - Work Sequence and Constraints, and Section 7.39 - Cooperation / Coordination and Work by Other.

**Issued for Bid**

June 12, 2019

# SANTA CLARA VALLEY TRANSPORTATION AUTHORITY

## CERONE DIVISION EMERGENCY GENERATOR REPLACEMENT

### CONTRACT C19010

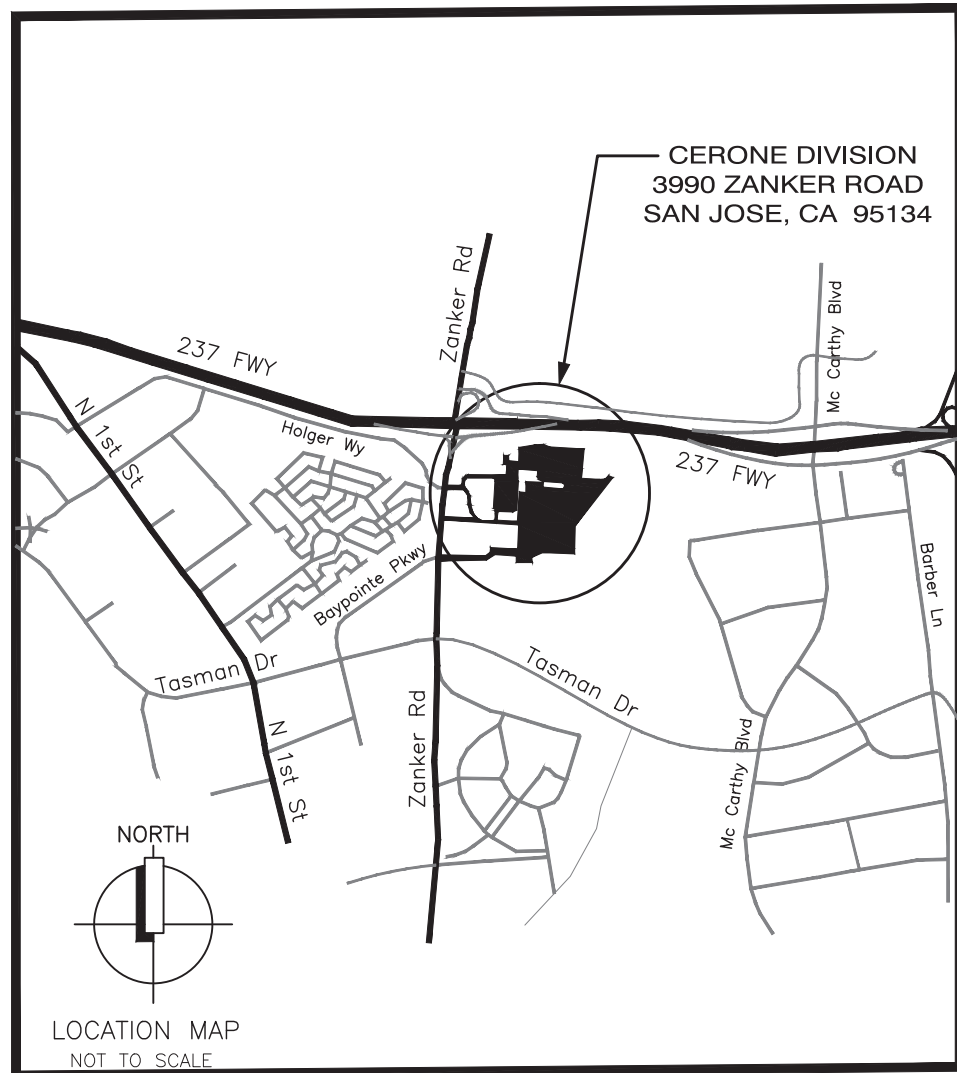

DRAWING INDEX		
SHEET	DWG NO	SHEET TITLE
1	T-1.0	TITLE SHEET
2	G-1.0	STAGING AND ACCESS PLAN
3	D-1.0	DEMOLITION SITE PLAN, NEW SITE PLAN
4	D-1.1	DEMOLITION FLOOR PLAN
5	A-4.0	BUILDING F SECTIONS & EXTERIOR ELEVATIONS
6	A-4.1	ARCHITECTURAL DETAILS
7	A-4.2	ARCHITECTURAL DETAILS
8	S-0.0	STRUCTURAL GENERAL NOTES & SPECIAL INSPECTION
9	S-1.0	BLDG F FLOOR PLAN
10	S-1.1	GENERATOR PAD AND PARTIAL SITE PLAN
11	S-2.0	STRUCTURAL DETAILS
12	S-2.1	STRUCTURAL DETAILS
13	E-1.0	ELECTRICAL NOTES & SYMBOLS
14	E-2.0	SINGLE LINE
15	E-2.1	GENERATOR SINGLE LINE
16	E-3.0	ELECTRICAL PLAN
17	E-3.1	GENERATOR ELECTRICAL SITE PLAN
18	-	<del>ELECTRICAL PLAN</del> <b>NOT USED</b>
19	E-4.0	ELECTRICAL DETAILS
20	E-4.1	GENERATOR & FUELING PANEL SCHEDULE
21	E-4.2	ATS SWITCH DIMENSIONS (ASCO 300)
22	E-4.3	ATS FRAME OUTLINE (ASCO 300)
23	E-4.4	(E) SWBD BUS CONFIGURATION
24	E-5.0	ELECTRICAL DETAILS
25	E-5.1	GENERATOR DETAILS
26	E-5.2	ELECTRICAL DETAILS
27	FE-2.0	FUEL ELECTRICAL PLAN
28	FS-2.0	FUEL PIPING PLAN
29	FS-5.0	P&I DIAGRAM
30	FS-6.0	FUEL EQUIPMENT SCHEDULE
31	FS-7.0	FUEL DETAILS
32	R-1.0	REFERENCE SHEET - TOPOGRAPHIC SURVEY
33	FS-1.1	REFERENCE SHEET - EXISTING SITE PLAN

ISSUED FOR BID

					<b>NOT USED</b>	CERONE DIVISION EMERGENCY GENERATOR REPLACEMENT	SHEET 1 OF 33 DRAWING NO. <b>T-10</b> REVISION		
NO.	DATE	REVISIONS	DESIGNED RP	CHECKED LM	CADD FILE DATE	SCALE NONE	SAP NO.	CONTRACT NO. C19010	FILE LOCATION
			DRAWN RP	CADD FILE NAME	PLOT DATE	BOARD APPROVAL DATE			



HIGHWAY 237

# PROJECT DESCRIPTION

1. SCOPE OF WORK: PROJECT CONSISTS OF THE REMOVAL OF TWO PROPANE FUELED STANDBY GENERATORS LOCATED INSIDE THE ENERGY BUILDING (BLDG. F) AT CERONE DIVISION, AND REPLACEMENT WITH A SINGLE DIESEL FUELED GENERATOR LOCATED OUTDOORS. PROJECT ALSO INCLUDES MODIFICATIONS TO AN EXISTING UNDERGROUND DIESEL STORAGE TANK, UNDERGROUND PIPING AND CONTROLS USED FOR BUS FUELING OPERATIONS. MODIFICATIONS TO BLDG. F INCLUDING STRUCTURAL, ELECTRICAL, MECHANICAL AND PLUMBING NECESSARY TO FACILITATE EQUIPMENT REMOVALS AND INSTALLATION. THE NEW GENERATOR SHALL SERVE AS THE PRIMARY ENERGY SOURCE BACK-UP SYSTEM DURING ENERGY INTERRUPTION. MAJOR COMPONENTS INCLUDE THE GENERATOR AND BELLY TANK, EQUIPMENT PAD AND FOUNDATION, FUEL PIPING, CONDUIT, WIRING AND AUTOMATIC TRANSFER SWITCH.

CAREFULLY EXAMINE THE CONTRACT DOCUMENTS FOR COMPLETE SCOPE OF WORK.

2. HAZARDOUS MATERIALS: HAZARDOUS MATERIALS ARE PRESENT IN BUILDING 'F' (ENERGY BUILDING). A REPORT ON THE PRESENCE OF HAZARDOUS MATERIALS IS INCLUDED IN THE APPENDIX. EXAMINE REPORT TO BECOME AWARE OF LOCATIONS WHERE HAZARDOUS MATERIALS ARE PRESENT, PRIOR TO COMMENCING DEMOLITION. CONTRACTOR'S WORK INCLUDES REMOVAL OF ALL ITEMS SHOWN ON THE CONTRACT DRAWINGS.

3. HAZMAT / ENVIRONMENTAL REGULATORY CLEARANCES: COMPLY WITH SPECIAL CONDITIONS - 6.7 "PERMITS, FEES AND INSPECTIONS". CONTRACTOR SHALL PROVIDE TO THE AUTHORITIES HAVING JURISDICTION (AHJ) ALL INFORMATION NECESSARY FOR HAZMAT / ENVIRONMENTAL PERMITS, CLEARANCES AND AUTHORIZATIONS NECESSARY FOR THIS PROJECT. CONTRACTOR SHALL COMPLY WITH ALL AHJ PROVISIONS, INCLUDING GIVING NOTICES FOR INSPECTIONS DURING CONSTRUCTION WHEN SO REQUIRED.

IDENTIFIED AUTHORITIES HAVING JURISDICTION:  
 SANTA CLARA COUNTY DEPARTMENT OF ENVIRONMENTAL HEALTH - HAZARDOUS MATERIALS COMPLIANCE DIVISION (HMCD). HMCD IS THE CERTIFIED UNIFIED PROGRAM AGENCY (CUPA) FOR THIS PROJECT.  
 BAY AREA AIR QUALITY MANAGEMENT DISTRICT (BAAQMD). CALIFORNIA DIVISION OF OCCUPATIONAL SAFETY AND HEALTH (DOSH)

4. PARKING: CONTRACTOR SHALL PROVIDE PARKING FACILITIES FOR CONTRACTOR PERSONNEL AND SUBCONTRACTORS. CONTRACTOR AND SUBCONTRACTOR ARE PROHIBITED FROM PARKING PERSONAL VEHICLES AT CERONE DIVISION, INCLUDING AREAS INDICATED ON THIS DRAWING AS VTA EMPLOYEE PARKING LOTS.

5. SITE ACCESS AND EGRESS: THE MAIN VEHICULAR AND PEDESTRIAN ACCESS TO THE SITE SHALL BE THE ENTRANCE GATE AT VTA SECURITY, AS INDICATED ON THIS SHEET.

6. CONTRACTOR USE OF PREMISES: COMPLY WITH SPECIAL CONDITIONS - 6.10 "WORK SEQUENCE AND CONSTRAINTS". CONSTRUCTION WILL BE PERFORMED ON AN ACTIVE SITE WITH ONGOING 24 HOURS A DAY BUS MAINTENANCE AND OPERATIONS ACTIVITY. COORDINATE, PHASE, SCHEDULE AND PERFORM WORK IN SUCH A MANNER THAT ONGOING VTA ACTIVITIES CONTINUE WITHOUT DISRUPTION.

# GENERAL NOTES

- NO DEVIATION FROM CONTRACT DOCUMENTS SHALL BE MADE WITHOUT PRIOR APPROVAL OF THE VTA RESIDENT INSPECTOR.
- DO NOT SCALE THE DRAWINGS. DIMENSIONS SHALL BE GOVERNED BY ACTUAL CONDITIONS AT THE SITE AND SHALL BE FIELD VERIFIED PRIOR TO COMMENCING CONSTRUCTION.
- WORK SHALL CONFORM TO ALL LOCAL, STATE, AND FEDERAL CODES AND ORDINANCES IN EFFECT. ALL SAFETY PROVISIONS SHALL BE STRICTLY ADHERED TO IN EVERY DETAIL. CONTRACTOR SHALL PROVIDE AND MAINTAIN PROPER BARRICADES, DUST CONTROL, LIGHTING AND ANY OTHER TEMPORARY DEVICES NECESSARY FOR THE PROTECTION OF LIFE AND PROPERTY, AND OF ONGOING BUS MAINTENANCE OPERATIONS.

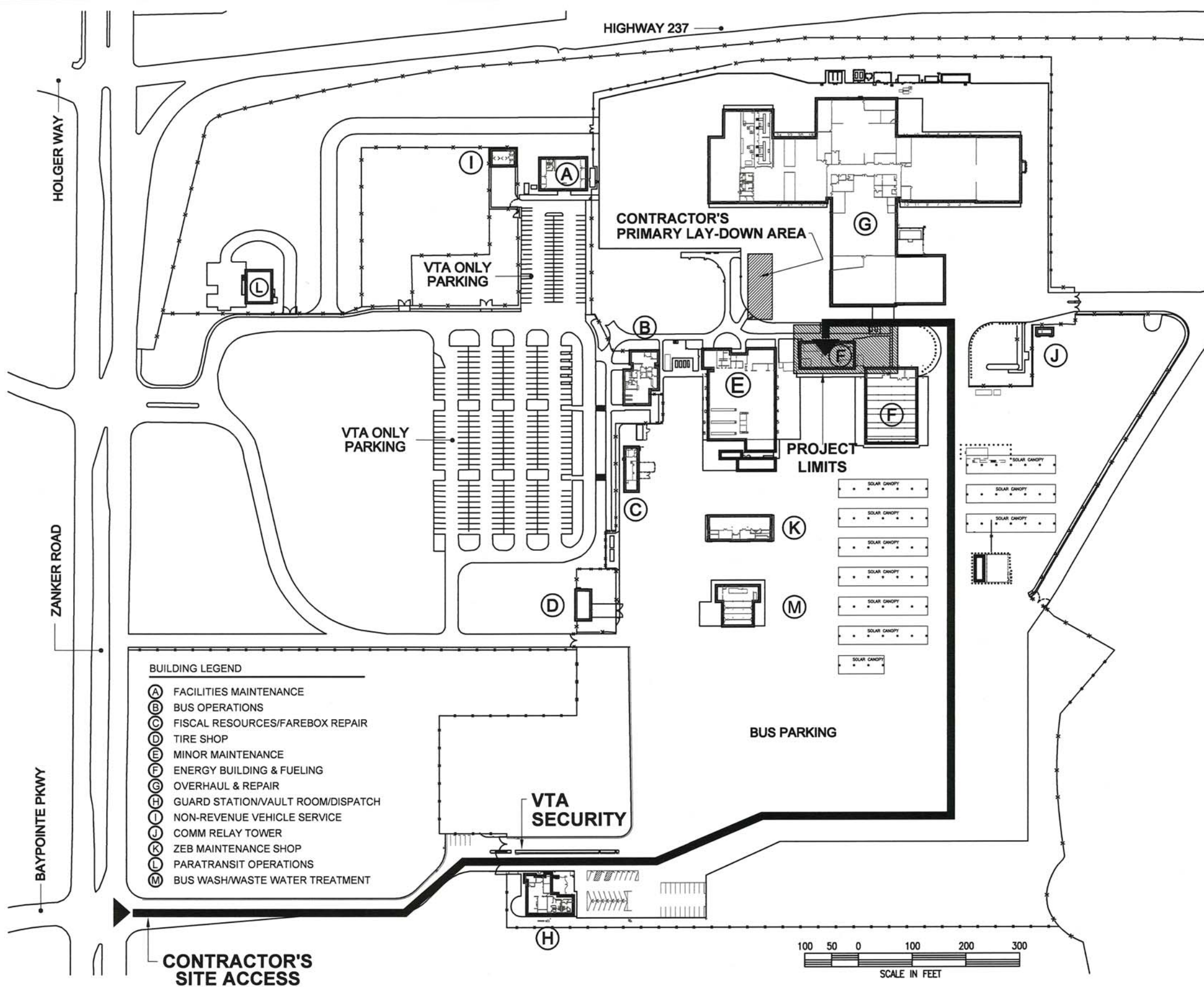

**BUILDING LEGEND**

(A)	FACILITIES MAINTENANCE
(B)	BUS OPERATIONS
(C)	FISCAL RESOURCES/FAREBOX REPAIR
(D)	TIRE SHOP
(E)	MINOR MAINTENANCE
(F)	ENERGY BUILDING & FUELING
(G)	OVERHAUL & REPAIR
(H)	GUARD STATION/VAULT ROOM/DISPATCH
(I)	NON-REVENUE VEHICLE SERVICE
(J)	COMM RELAY TOWER
(K)	ZEB MAINTENANCE SHOP
(L)	PARATRANSIT OPERATIONS
(M)	BUS WASH/WASTE WATER TREATMENT

**CONTRACTOR'S SITE ACCESS**

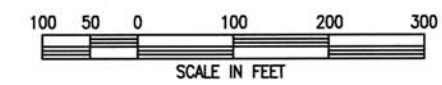

NO.	DATE	REVISIONS
1		ISSUED FOR BID



SUBMITTED		
DESIGNED	JO	CHECKED JO
DRAWN	JO	CADD FILE NAME



APPROVED	
CADD FILE DATE	SCALE 1" = 100'
PLLOT DATE	BOARD APPROVAL DATE

CERONE DIVISION EMERGENCY GENERATOR REPLACEMENT			SHEET 2 OF 33 DRAWING NO. G-1.0
<b>STAGING AND ACCESS PLAN</b>			REVISION
SAP NO.	CONTRACT NO. C19010	FILE LOCATION	



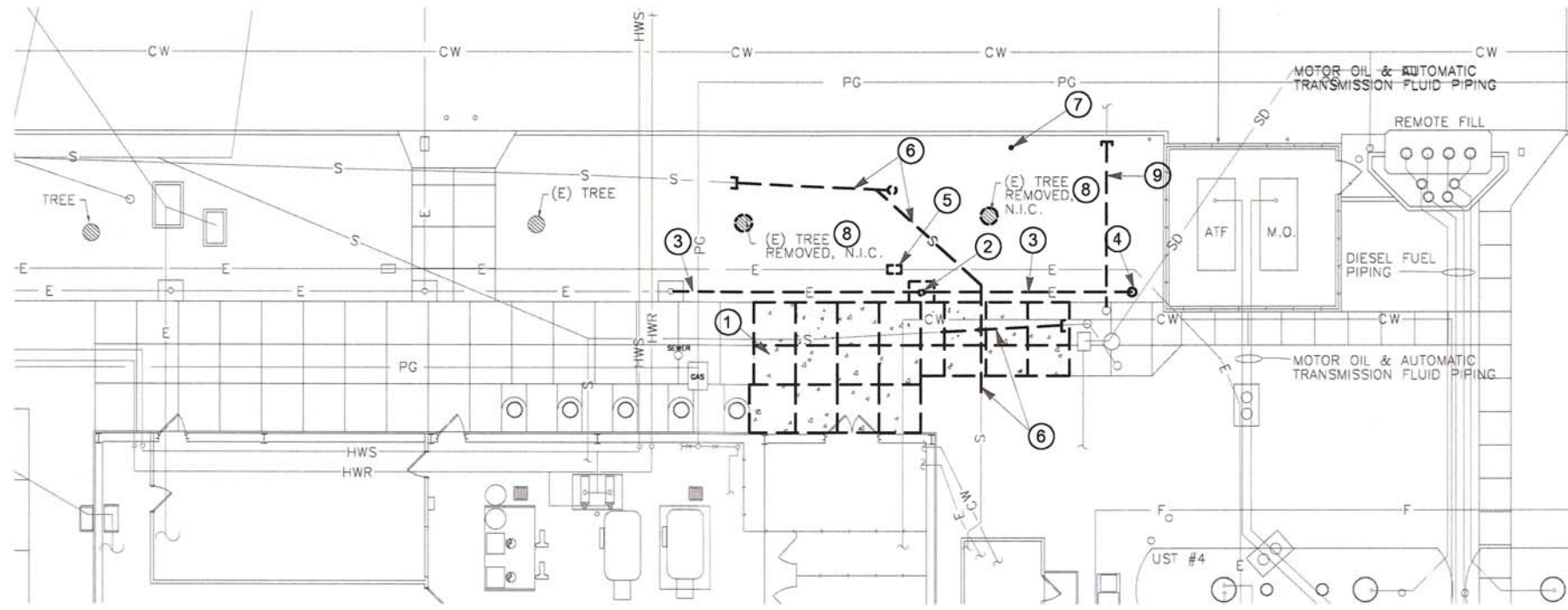

**DEMOLITION**

--- REMOVE EXISTING  
 ——— EXISTING TO REMAIN

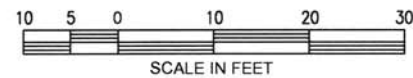

SEE ENLARGED PLAN

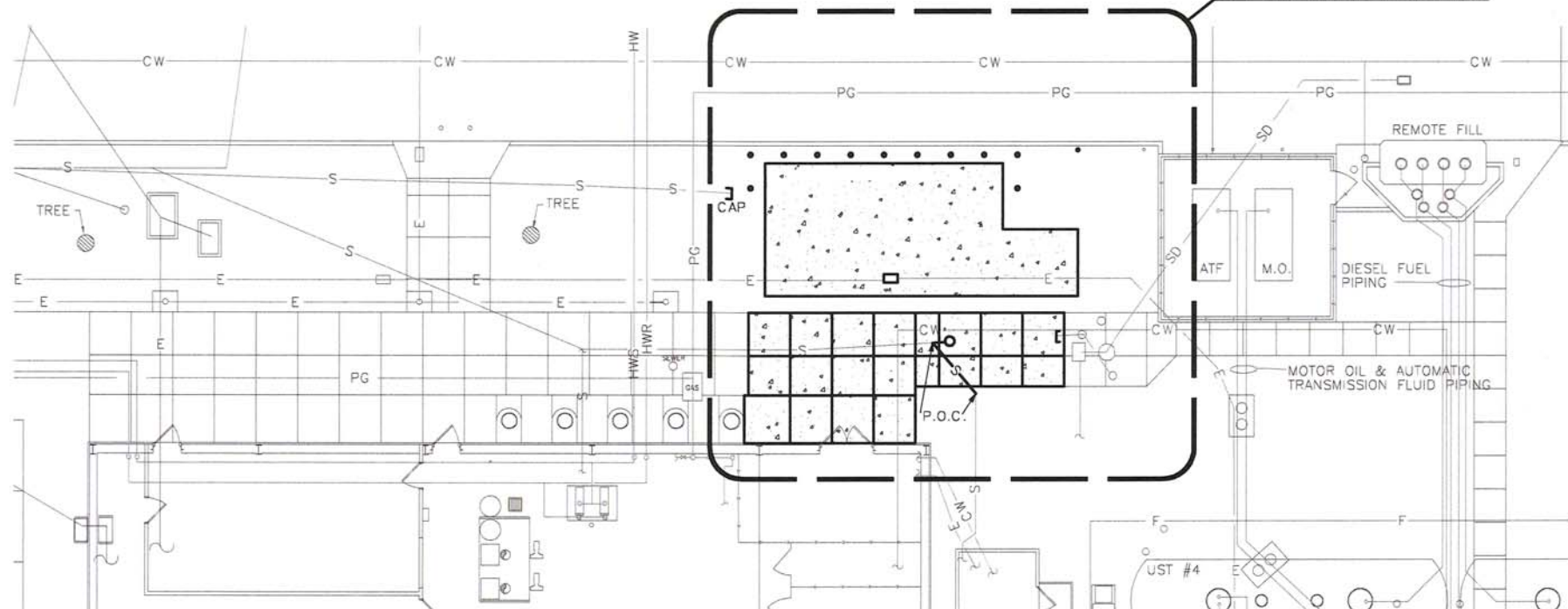

**(N) WORK**



**GENERAL NOTES:**

- REFER TO 'E' AND 'F' SHEETS FOR ELECTRICAL AND FUELING WORK NOT NOTED ON THIS SHEET.
- REFER TO 'E' AND 'F' SHEETS FOR ADDITIONAL LOCATIONS REQUIRING SAWCUT AND REMOVAL OF (E) CONCRETE FOR TRENCHING AND PIPING WORK.

**KEYED NOTES:**

- SAWCUT AND REMOVE CONCRETE SIDEWALK.
- REMOVE LIGHT BOLLARD, INCLUDING CONCRETE FOUNDATION.
- REMOVE CONDUIT AND CONDUCTORS BACK TO NEAREST OPERATING LIGHT BOLLARD.
- REMOVE ELECTRICAL PULL BOX.
- REPLACE ELECTRICAL CHRISTY BOX WITH (N), MATCH (E) SIZE; RAISE TOP OF BOX TO (N) ELEVATION.
- REMOVE (E) SEWER PIPE AND CLEANOUT; CAP (E) PIPE AT LOCATION SHOWN.
- REMOVE SIGNAGE, POST AND FOUNDATION; REATTACH SIGNAGE TO (N) POST AND FOUNDATION, MATCH (E) POST SIZE AND MOUNTING HEIGHT.
- REMOVE TREE ROOTS IN WAY OF (N) WORK.
- CAP AND REMOVE (E) ABANDONED STORM DRAIN PIPING.
- (N) CONCRETE SIDEWALK TO MATCH (E) THICKNESS AND FINISH, SEE STRUCT; PROVIDE JOINT SPACING TO MATCH (E).
- (N) CONCRETE GENERATOR SLAB, SEE STRUCT.
- (N) BOLLARD @ 4' O.C., TYP. OF 11, SEE STRUCT. PRIME AND PAINT SAFETY YELLOW.
- (N) SIGNPOST AND CONCRETE FOUNDATION; REATTACH (E) SIGNAGE.
- (N) SANITARY SEWER CLEANOUT.
- (N) SEWER PIPE; MATCH (E) DIAMETER/ PROVIDE TRANSITION COUPLING WHEN JOINING DIFFERENT TYPES OF PIPING TOGETHER.

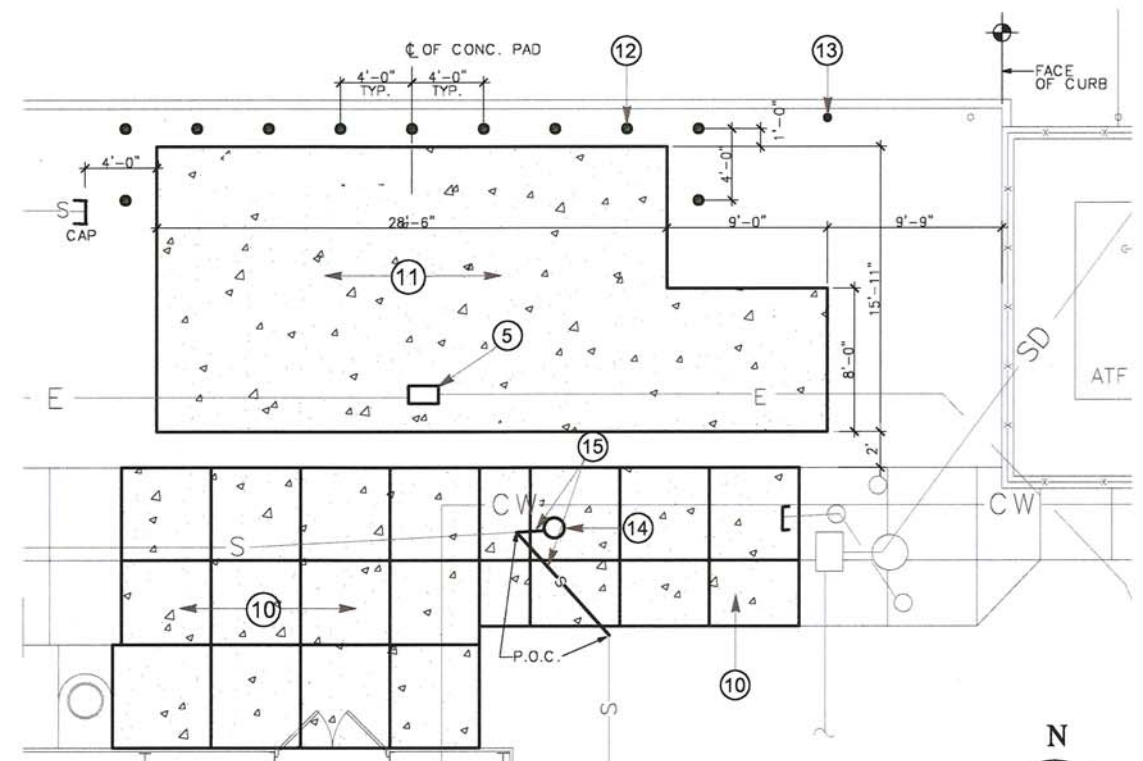

**(N) WORK - ENLARGED PLAN**



		SUBMITTED DESIGNED RB CHECKED JO DRAWN RB CADD FILE NAME				APPROVED CADD FILE DATE PLOT DATE SCALE 1" = 10' BOARD APPROVAL DATE		CERONE DIVISION BOILER AND PROPANE TANK REPLACEMENT PARTIAL SITE PLAN SAP NO. CONTRACT NO. C19010 FILE LOCATION		SHEET 3 OF 33 DRAWING NO. D-1.0 REVISION
1	ISSUED FOR BID									
NO.	DATE	REVISIONS								



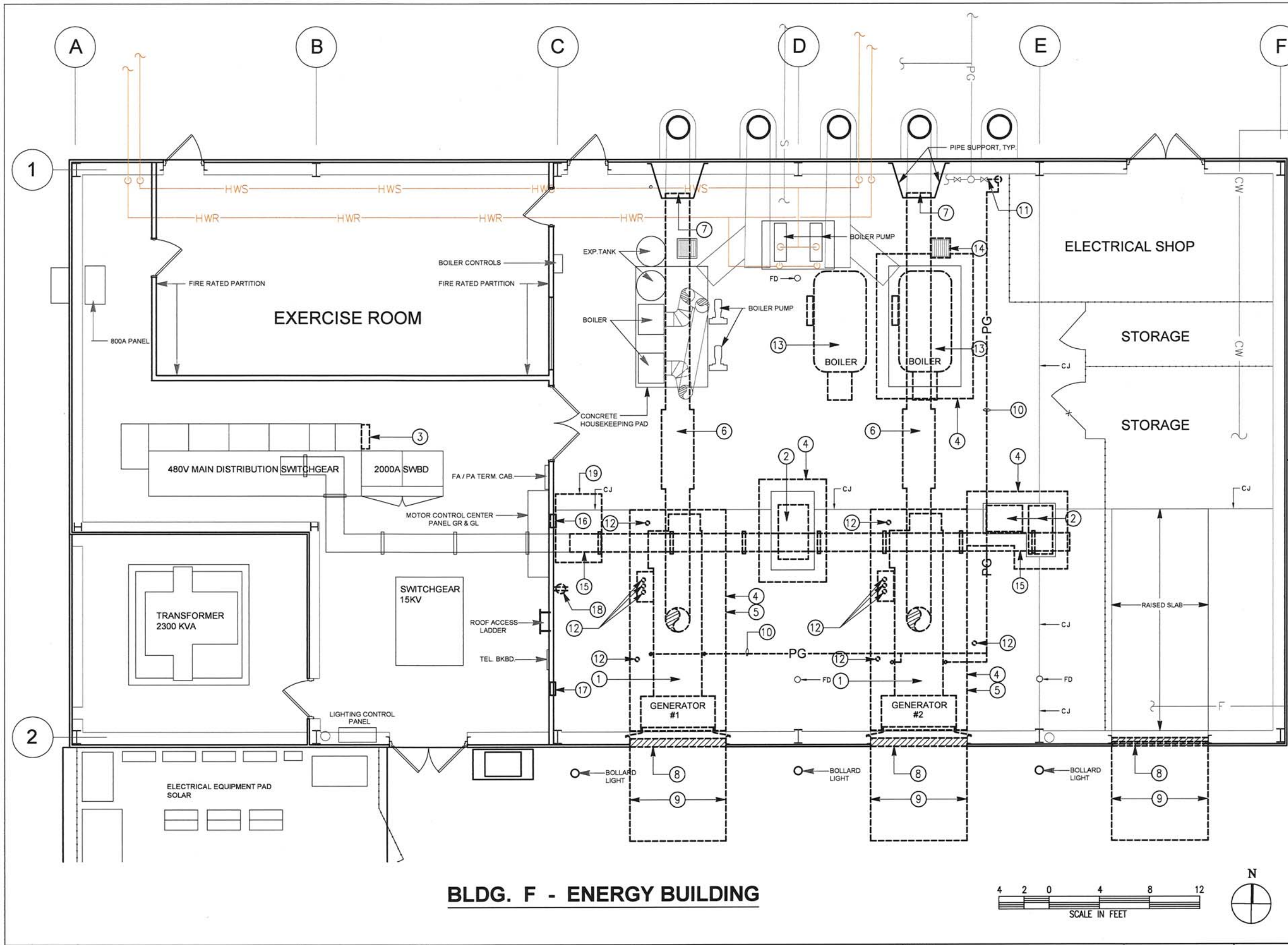

**LEGEND:**

- REMOVE EXISTING
- \_\_\_\_\_ EXISTING TO REMAIN

**NOTES:**

1. REFER TO 'E' AND 'F' SHEETS FOR DEMOLITION WORK NOT NOTED ON THIS SHEET.
2. REFER TO 'S' SHEETS FOR NEW CONCRETE INFILL WORK.

**KEYED NOTES:**

- 1 REMOVE ENGINE GENERATOR SET IN ITS ENTIRETY. REMOVALS INCLUDE MOUNTING FRAME AND HARDWARE, PROPANE FUEL, COOLANT, BATTERY AND ALTERNATOR, CONTROLS, HOSES, CABLES, FITTINGS AND ALL RELATED EQUIPMENT; SEE ELEC.
- 2 REMOVE GENERATOR CONTROL PANEL, CONDUCTORS, CONDUIT AND FITTINGS; SEE ELEC.
- 3 REMOVE TRANSFER SWITCH CONTROL PANEL, CONDUCTORS, CONDUIT AND FITTINGS; SEE ELEC.
- 4 SAWCUT AND REMOVE RAISED STRUCTURAL GENERATOR/BOILER SLAB, INCLUDING FOUNDATION; SEE STRUCT., 6/S2.0  
NOTE: (E) REBARS ARE CONTINUOUS AT TRANSITION FROM FINISHED FLOOR SLAB TO RAISED SLAB, TYP. AT ALL RAISED SLAB LOCATIONS, EXCEPT AT GENERATOR #1 AND #2.
- 5 REMOVE POLYSTYRENE EXPANSION JOINT MATERIAL, TYP. OCCURS ALONG ENTIRE PERIMETER OF GENERATOR SLAB; SEE STRUCT., 6/S2.0.
- 6 CUT AND REMOVE GENERATOR EXHAUST PIPE. REMOVAL SHALL INCLUDE PIPE INSULATION, MUFFLER, FITTINGS AND ALL RELATED EQUIPMENT. REMOVE BRACING, SUPPORTS, FITTINGS AND FASTENINGS TO UNDERSIDE OF ROOF DECK.  
NOTE: (E) PIPE IS SCHED. 40 BLACK STEEL.
- 7 CAP/SEAL GENERATOR EXHAUST PIPE HERE.
- 8 REMOVE EXHAUST DEFLECTOR AND LOUVER. PREP OPENING TO RECEIVE NEW WALL FINISHES.
- 9 REMOVE LOUVER. PREP OPENING TO RECEIVE NEW WALL FINISHES.
- 10 REMOVE PROPANE LINE FROM GENERATOR TO ISOLATION VALVE @ GRID LINE '1' AND 'E'.
- 11 PROVIDE BLANK OFF FLANGE AT ISOLATION VALVE.
- 12 REMOVE ALL GENERATOR CONDUIT TO BELOW TOP OF (E) SLAB. CHIP OUT AND REPAIR (E) SLAB WITH REPAIR MORTAR. REMOVE CONDUCTORS BACK TO THE ELECTRICAL PANEL FROM WHICH THEY ORIGINATE; REMOVE ALL JUNCTION BOXES AND DISCONNECT SWITCHES.
- 13 REMOVE BOILER, INCLUDING MOUNTING FRAME AND HARDWARE.  
NOTE: EXHAUST PIPE, PIPE INSULATION, HANGERS, MUFFLER, AND EXPANSION TANK ARE (E) TO REMAIN.
- 14 REMOVE FLOOR GRATE AND FRAME; CHIP OUT CONCRETE AS REQ'D TO REMOVE FRAME; REMOVE FLOOR SINK, DRAIN DOME STRAINER AND CAP SANITARY SEWER. INFILL OPENING WITH (N) CONCRETE; SEE STRUCT.
- 15 REMOVE 3000A BUSWAY; SEE ELEC. MODIFY HANGER ROD SUPPORTS TO SUIT CONDUITS TO REMAIN; SEE SH. A-4.2.
- 16 REMOVE RECESSED FIRE EXTINGUISHER CABINET (FEC). FILL IN AND PATCH WALL OPENING TO MATCH (E). RELOCATE FEC TO LOCATION SHOWN.
- 17 NEW LOCATION FOR RELOCATED FEC.
- 18 REMOVE RECEPTACLE AND RECEPTACLE BOX. PATCH WALL OPENING TO MATCH (E).
- 19 SAWCUT AND REMOVE FOR (N) TRANSFER SWITCH HOUSEKEEPING PAD; SEE ELEC.

**BLDG. F - ENERGY BUILDING**

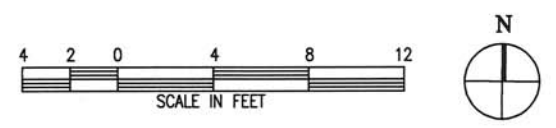

NO.	DATE	REVISIONS
1		ISSUED FOR BID



SUBMITTED	
DESIGNED	JO
CHECKED	JO
DRAWN	JO
CADD FILE NAME	



APPROVED	
CADD FILE DATE	SCALE 1/4" = 1'-0"
PLT DATE	BOARD APPROVAL DATE

CERONE DIVISION EMERGENCY GENERATOR REPLACEMENT <b>DEMOLITION FLOOR PLAN</b>			SHEET 4 OF 33 DRAWING NO. D-1.1 REVISION
BAP NO.	CONTRACT NO. C19010	FILE LOCATION	



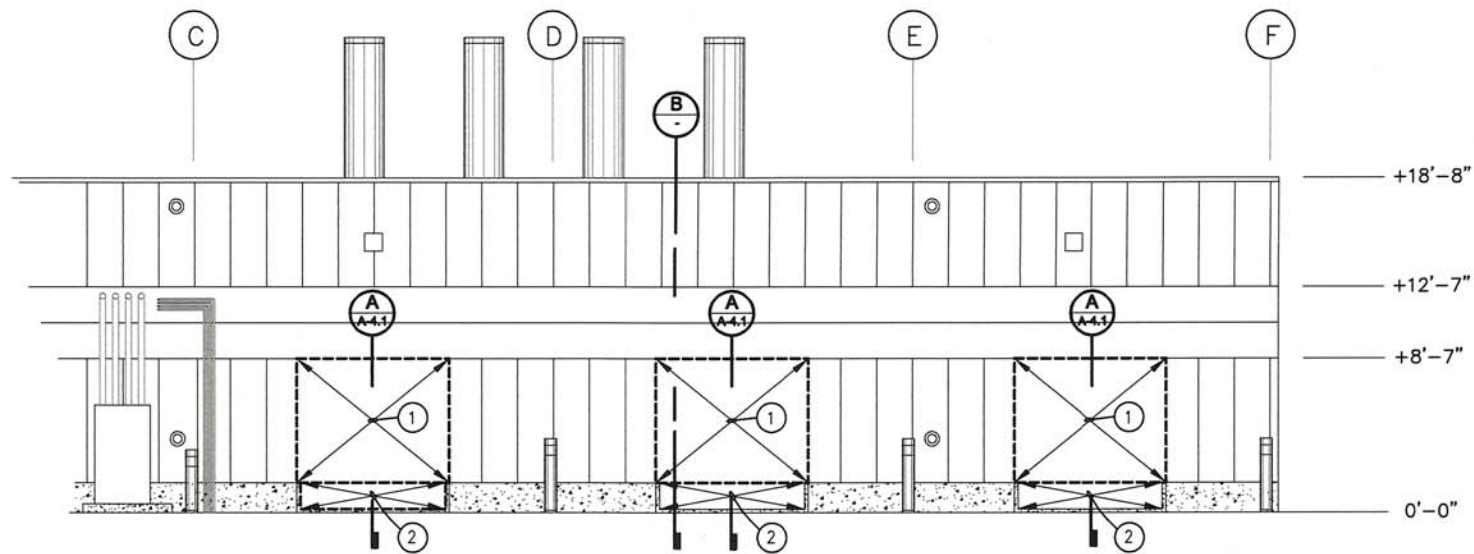

**A** EXT. ELEVATION - DEMOLITION

- ① REMOVE EXHAUST DEFLECTOR AND LOUVER; SEE DTL. A, SH. A-4.1
- ② REMOVE INSULATED METAL SIDING; SEE DTL. A, SH. A-4.1
- ③ REMOVE GENERATOR SET IN ITS ENTIRETY; SEE ELEC.
- ④ REMOVE GENERATOR EXHAUST PIPE, FITTINGS AND INSULATION.
- ⑤ REMOVE RAISED CONCRETE EQUIPMENT PAD AND EXPANSION JOINT MATERIAL; SEE STRUCT.
- ⑥ SAWCUT AND REMOVE RAISED CONCRETE PAD AND ADJACENT FLOOR SLAB; SEE STRUCT.
- ⑦ CAP/SEAL GENERATOR EXHAUST PIPE HERE.

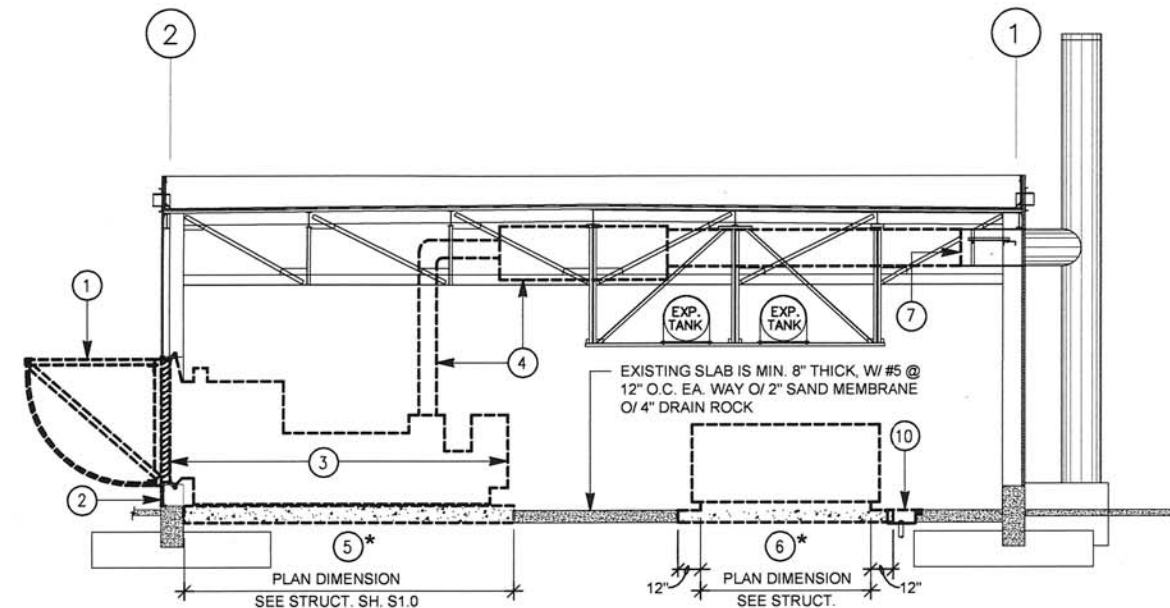

**B** SECTION - DEMOLITION

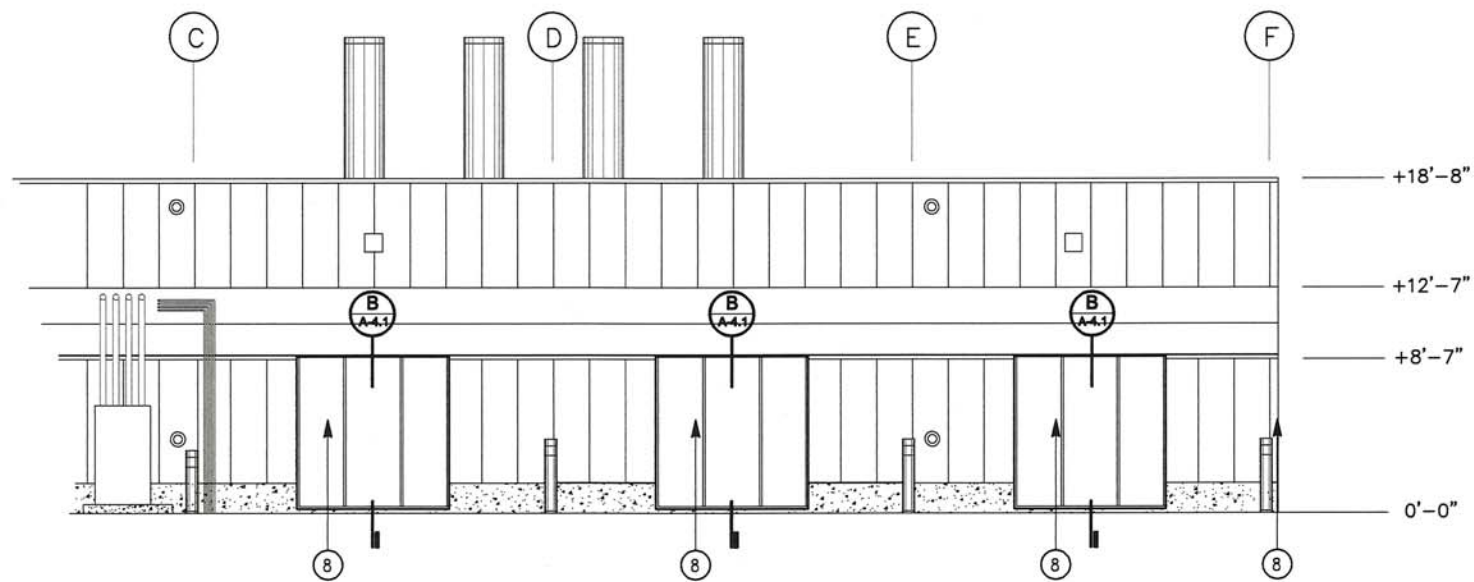

**C** EXT. ELEVATION - (N) WORK

- ⑧ (N) FIBER CEMENT SIDING; SEE DTL. B, SH. A-4.1
- ⑨ (N) CONCRETE SLAB; SEE STRUCTURAL.
- ⑩ REMOVE FLOOR SINK, STRAINER, FLOOR GRATE AND FRAME.
- ⑪ (N) INFILL SLAB AT REMOVED FLOOR SINK LOCATION; SEE STRUCTURAL.

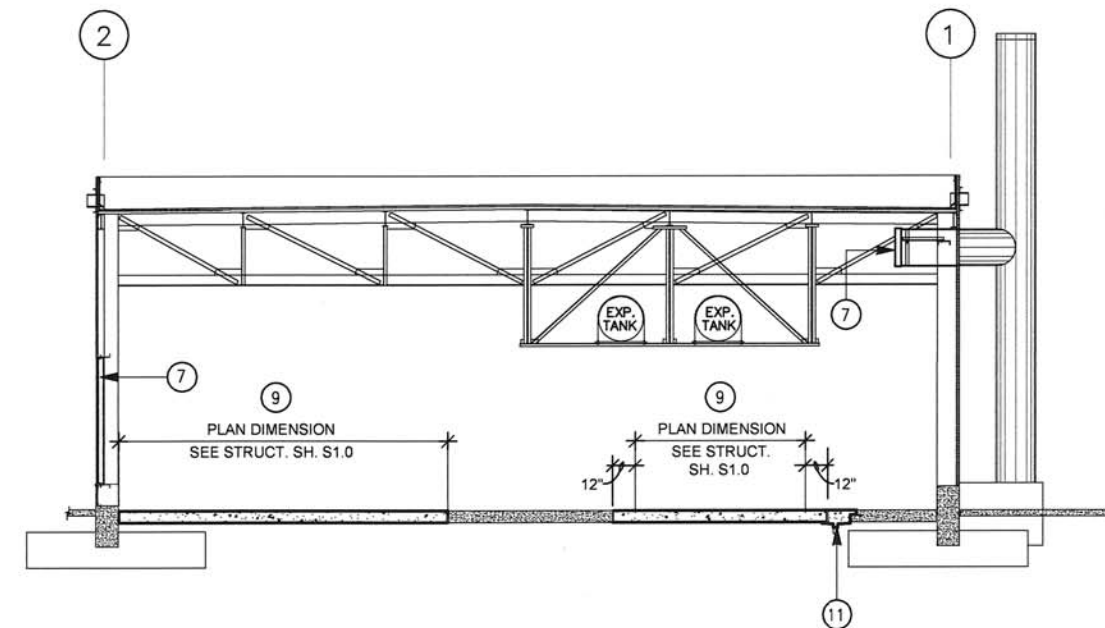

**D** SECTION - (N) WORK

		SUBMITTED DESIGNED RB DRAWN RB				APPROVED CADD FILE DATE PLOT DATE		SCALE 3/16" = 1'-0" BOARD APPROVAL DATE		CERONE DIVISION EMERGENCY GENERATOR REPLACEMENT <b>ELEVATION AND SECTION</b>		SHEET OF 33 <b>5</b> DRAWING NO. <b>A-4.0</b> REVISION
1	ISSUED FOR BID	REVISIONS	CHECKED JO CADD FILE NAME	CONTRACT NO. C19010		FILE LOCATION						

**NOTES:**

- FOR GENERATOR PAD AND SIDEWALK SLAB, SEE SHEET S1.1.
- SEE ARCHITECTURAL DRAWINGS FOR ALL EQUIPMENT LAYOUT, DEMOLITION PLAN, AND ALL DIMENSIONS NOT SHOWN.
- MATCH SLOPES OF INFILL SLABS WITH (E) FLOOR SLAB.
- SEE  $\frac{6}{S2.0}$  FOR LIMITS OF (E) CONCRETE SLAB REMOVAL.
- SEE ELECTRICAL DRAWINGS (SHEET E4.2) FOR TRANSFER SWITCH HOUSEKEEPING PAD.

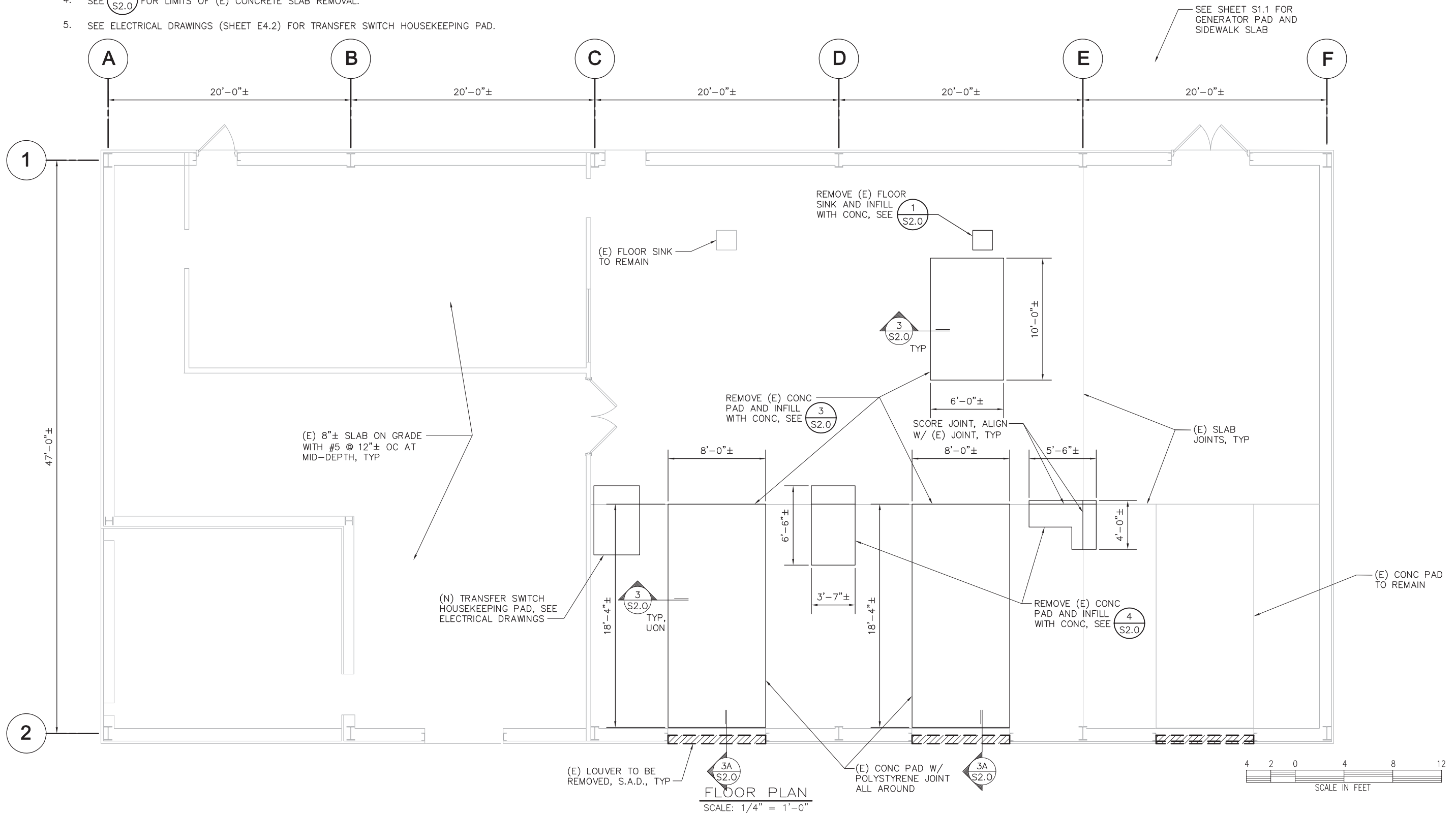

**FLOOR PLAN**  
SCALE: 1/4" = 1'-0"

R:\0 - Jun 04, 2019 - 12:07pm W:\2018\201813\201813510.dwg

NO.	DATE	REVISIONS
1		ISSUED FOR BID



**SUBMITTED**  
**BIGGS CARDOSA ASSOCIATES INC**  
STRUCTURAL ENGINEERS  
865 The Alameda  
San Jose, California 95126  
408-296-5515

**DESIGNED** G.J. TOLAN  
**CHECKED** D.B. DEVLIN  
**DRAWN** R.L. QUETULIO  
**CADD FILE NAME** 2018113510



APPROVED	
<b>CADD FILE DATE</b> JUNE 4, 2019	<b>SCALE</b> AS NOTED
<b>PLOT DATE</b> JUNE 4, 2019	<b>BOARD APPROVAL DATE</b>

**CERONE DIVISION**  
**EMERGENCY GENERATOR**  
**REPLACEMENT**  
**GROUND FLOOR PLAN - BUILDING F**

**SAP NO.**      **CONTRACT NO.** C19010      **FILE LOCATION** W:\2018\2018113

**SHEET** 9  
**OF 33**  
**DRAWING NO.** S1.0  
**REVISION** A

2018113

**NOTES:**

1. SEE ARCHITECTURAL DRAWINGS FOR DEMOLITION PLAN, ALL EQUIPMENT LAYOUT, ALL DIMENSIONS NOT SHOWN.
2. SEE ARCHITECTURAL DRAWINGS FOR BOLLARD LAYOUT.
3. SEE ARCHITECTURAL DRAWINGS FOR TOP OF CONC SLAB ELEVATIONS AND LOCATION OF SIDEWALK SLAB JOINTS.
4. SEE SHEET R-1.1 FOR EXISTING GRADE ELEVATIONS.
5. SEE ARCHITECTURAL DRAWINGS AND ELECTRICAL DRAWINGS FOR SIZE AND LOCATION OF SLAB OPENINGS.
6. SEE ELECTRICAL DRAWINGS FOR SIZE AND LOCATION OF TRANSITION SUMP.
7. COORDINATE GENERATOR/FUEL TANK ANCHOR BOLT LOCATIONS W/ EQUIPMENT MANUFACTURER/SUPPLIER BEFORE PLACEING CONCRETE FOR GENERATOR PAD.

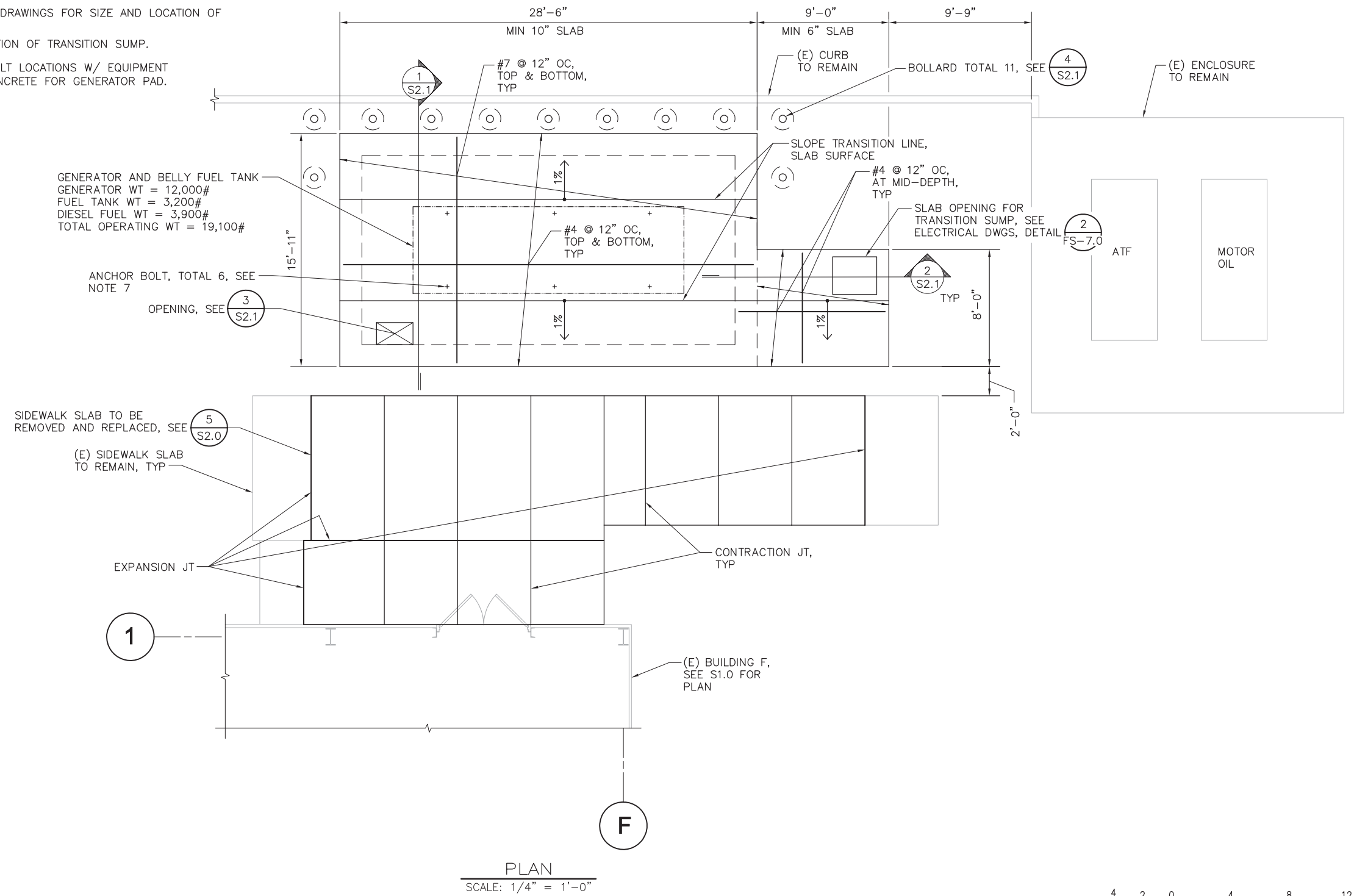

PLAN  
SCALE: 1/4" = 1'-0"

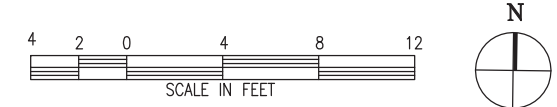

R:\0 - Jun 04, 2019 - 12:18pm W:\2018\2018113\2018113511.dwg

NO.	DATE	REVISIONS
1		ISSUED FOR BID

**SUBMITTED**  
**BIGGS CARDOSA ASSOCIATES INC**  
STRUCTURAL ENGINEERS

865 The Alameda  
San Jose, California 95126  
408-296-5515

**DESIGNED** G.J. TOLAN  
**CHECKED** D.B. DEVLIN  
**DRAWN** R.L. QUETULIO  
**CADD FILE NAME** 2018113S10

**Santa Clara Valley Transportation Authority**

<b>APPROVED</b>	
<b>CADD FILE DATE</b> JUNE 4, 2019	<b>SCALE</b> AS NOTED
<b>PLOT DATE</b> JUNE 4, 2019	<b>BOARD APPROVAL DATE</b>

**CERONE DIVISION  
EMERGENCY GENERATOR  
REPLACEMENT  
GENERATOR PAD LAYOUT**

**SAP NO.**      **CONTRACT NO.** C19010      **FILE LOCATION** W:\2018\2018113

**SHEET** 10  
**OF 33**  
**DRAWING NO.** S1.1  
**REVISION** A

# SANTA CLARA VTA CERONE FACILITY

PG&E  
SANTA CLARA VTA

POINT OF CHANGE OF OWNERSHIP

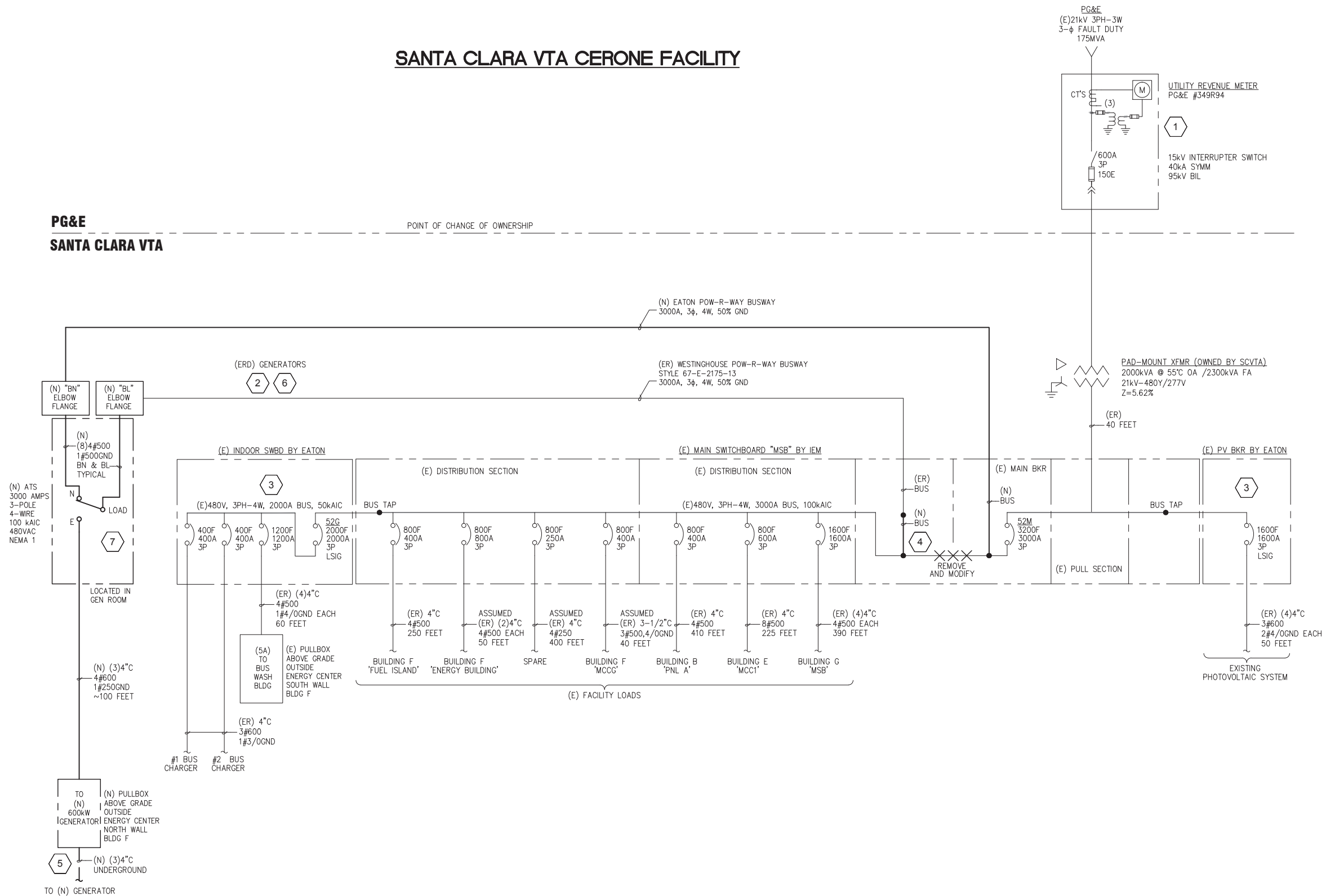

## GENERAL NOTES

1. ALL (N) EQUIPMENT SHALL BE UL LISTED OR UTILITY GRADE AND APPROVED BY VTA. THE AHJ HAS FINAL JURISDICTIONAL AUTHORITY ON CODE APPLICATION AND COMPLIANCE.
2. ALL GENSET WIRING AND GROUNDING METHODS SHALL CONFORM TO THE MANUFACTURER'S RECOMMENDED PRACTICES.
3. EXPOSED NON-CURRENT CARRYING METAL PARTS OF EQUIPMENT AND ENCLOSURES SHALL BE GROUNDED IN ACCORDANCE WITH NEC 250.134 AND 250.136(A).
4. ALL BREAKERS AND DISCONNECT SWITCHES ARE CLOSED UNDER NORMAL OPERATING CONDITIONS UNLESS OTHERWISE NOTED.
5. DISTANCES SHOWN ARE APPROXIMATE. CONTRACTOR SHALL VERIFY ACTUAL DISTANCES IN FIELD.
6. HEAVY LINE WEIGHT INDICATE (N) WORK.

## KEYED NOTES

- 1 (ER) MAIN SERVICE METERING AND MAIN DISCONNECT IS LOCATED IN PG&E SERVICE ENCLOSURE IN "ENERGY BUILDING" F.
- 2 REFER TO SHEET E-3.X FOR ADDITIONAL DEMOLITION NOTES AND DETAILS NOT SHOWN ON THIS SHEET.
- 3 (ER) 2000A 480/277V, 3φ, 4W SWBD AND (ER) 1600A PV DISCONNECT ARE LOCATED IN "ENERGY BUILDING" F.
- 4 REMOVE EXISTING 3000 AMPS GENERATOR BREAKER AND AUTOMATIC THROWOVER CONTROLS. REMOVE/DIVIDE BUSING IN THE LOWER SECTION OF EXISTING MSB SWBD. EXTEND 3000 AMPS (ER) BUS RISER IN THE GENERATOR SECTION TO THE LOWER/HORIZONTAL SECTION OF THE BUS AS REQUIRED; PROVIDE NEW 3000A BUS RISER IN THE MAIN BREAKER COMPARTMENT TO THE TOP OF MSB SWBD. PROVIDE UL LABELING FOR ALL MODIFICATIONS TO MSB SWBD. PROVIDE (N) ARC-FLASH WARNING LABELS AS REQUIRED PER NEC 110.16. THE SHORT CIRCUIT RATING OF EXISTING MAIN SWBD MUST REMAIN UNCHANGED, 100KAIC AT 480VAC. SEE SHEET E-4.4.
- 5 PROVIDE (N) MULTIPLE CONDUITS FOR AUXILIARY POWER, ALARMS AND CONTROL CIRCUITS BETWEEN (N) 600kW GENERATOR, ATS AND 208Y/120V PANELBOARD. REFER TO SHEET E-2.1, AND E-3.1 FOR CONDUIT SCHEDULE.
- 6 COORDINATE ALL DEMOLITION WITH NEW WORK TO MINIMIZE DOWNTIME DURATION. AFTER REMOVING EXISTING GENERATOR'S 3000A BUSWAY AND CONTROL WIRING, CLEAN AND PROTECT EXISTING EQUIPMENT. RECONNECT ANY EXISTING LOADS TO REMAIN.
- 7 (N) ATS DELAYED-TRANSITION TRANSFER DEVICE TO BE BASED ON LOW VOLTAGE 3000AMP FRAME DOUBLE-THROW OPERATION SWITCH. AUTOMATIC CONTROLLER TO COMPLETELY MANAGE BOTH INITIATION AND OPERATION OF NEW GENERATOR. ASCO PART # G3ADTS-A33000N-GX-C. PROVIDE OPTIONAL ACCESSORIES: 1UP (30SEC BACKUP POWER), 135L (POWER METER), 72EE CONNECTIVITY MODULE, 11BE (PROGRAMMABLE ENGINE EXERCISER WITH RS485 COMM. PORT), 44G (STRIP HEATER).

## ABBREVIATIONS

- (BL) BUS LOAD
- (BN) BUS NORMAL
- (E) EXISTING
- (ER) EXISTING TO REMAIN
- (ERD) REMOVE EXISTING
- (F) FUTURE
- (N) NEW
- (R) RECONNECT EXISTING



SUBMITTED

**BLMYER ENGINEERS**

DESIGNED RP CHECKED LM

DRAWN RP CADD FILE NAME



APPROVED

CADD FILE DATE SCALE NONE

PLOT DATE BOARD APPROVAL DATE

CERONE DIVISION  
EMERGENCY GENERATOR  
REPLACEMENT  
SINGLE LINE

SHEET 14 OF 33 DRAWING NO. E-2.0 REVISION

SAP NO. CONTRACT NO. C19010 FILE LOCATION

NO.	DATE	REVISIONS
1		ISSUED FOR BID



**GENERAL NOTES**

1. ALL (N)EQUIPMENT SHALL BE UL LISTED OR UTILITY GRADE AND APPROVED BY VTA. THE AHJ HAS FINAL JURISDICTIONAL AUTHORITY ON CODE APPLICATION AND COMPLIANCE.
2. ALL GENSET WIRING AND GROUNDING METHODS SHALL CONFORM TO THE MANUFACTURER'S WRITTEN RECOMMENDED PRACTICES.
3. EXPOSED NON-CURRENT CARRYING METAL PARTS OF EQUIPMENT AND ENCLOSURES SHALL BE GROUNDED IN ACCORDANCE WITH NEC 250.134 AND 250.136(A).

**KEYED NOTES NEW WORK**

- 1 (ER) MAIN SERVICE METERING AND MAIN DISCONNECT IS LOCATED IN PG&E SERVICE ENCLOSURE IN BUILDING F.
- 2 PROVIDE (N)3000 AMP ATS, BUSING AND RACEWAYS. USE EXISTING SUPPORTS AS APPLICABLE. MODIFY EXISTING MSB SWBD AFTER REMOVING GENERATOR BREAKER. RECONNECT EXISTING FEEDERS AS NECESSARY. MSB SWBD SHALL RETAIN 100 KAIC AT 480VAC SHORT CIRCUIT RATING. COORDINATE ALL DEMOLITION WITH NEW WORK TO MINIMIZE DOWNTIME DURATION. AFTER REMOVING EXISTING FEEDERS AND WIRING, CLEAN AND PROTECT EXISTING EQUIPMENT. RECONNECT EXISTING LOADS TO REMAIN TO SWBD AND/OR PANELBOARD.
- 3 PROVIDE TEMPORARY POWER FROM PORTABLE GENERATORS FOR SELECTED LOADS FED FROM MSB. COORDINATE PORTABLE GENERATOR SIZE AND CONNECTION POINTS WITH VTA. REFER TO SHEET E-3.2.
- 4 PROVIDE (N)600 kW 0.8PF 480Y/277V STAND-BY GENERATOR IN SOUND ATTENUATED CORROSION RESISTANT ENCLOSURE.
- 5 PROVIDE (N)FUELING SYSTEM FOR (N)600kW GENERATOR. REFER TO FS & FE SERIES DRAWINGS.
- 6 PROVIDE (N) PULL-BOX WITH TERMINALS ABOVE GRADE ON NORTH WALL BLDG F FOR TRANSITION EXPOSED RACEWAYS TO UNDERGROUND.
- 7 PROVIDE (N) THREE (3) 4" GR S CONDUIT WITH 4#600, 1#250GND EACH TO CONNECT NEW PULLBOX TO ATS.
- 8 PROVIDE (N) THREE (3) 4" PVC SCHEDULE 80 UNDERGROUND CONDUIT WITH 4#600, 1#250GND EACH TO CONNECT NEW PULLBOX TO 600kW GENERATOR.
- 9 PROVIDE (N) MULTIPLE CONDUITS FOR AUXILIARY POWER, ALARMS AND CONTROL CIRCUITS BETWEEN (N)600kW GENERATOR, ATS AND 208Y/120V PANELBOARD. REFER TO SHEET E-2.1, AND E-3.1 FOR CONDUIT SCHEDULE.
- 10 PROVIDE (N)AUTOMATIC TRANSFER SWITCH (ATS).

**ELECTRICAL DEMOLITION NOTES**

1. (E) EQUIPMENT AND/OR WIRING WHICH ARE TO REMAIN, BUT HAVE BEEN REMOVED TO FACILITATE THE INSTALLATION OF NEW EQUIPMENT SHALL BE RESTORED TO ITS ORIGINAL OPERATING CONDITION. ALL REMOVED WIRING SHALL BE REPLACED WITH NEW WIRING.
2. REMOVED FIXTURES AND EQUIPMENT SHALL HAVE ALL WIRING REMOVED BACK TO THE PANEL FROM WHICH IT IS SERVED. MARK ALL DISASSOCIATED BREAKER "SPARE". IF REMOVAL OF WIRING AFFECT POWER TO OTHER OUTLETS AND FIXTURE TO REMAIN, PROVIDE J-BOXES AND EXTEND WIRING AS NECESSARY, TO RESTORE POWER TO THESE OUTLETS AND FIXTURES.
3. REMOVE ALL EMPTY CONDUITS BACK TO THE PANELBOARD OR TO THE CONCRETE SURFACE FROM WHICH IT EMERGES. REMOVE ALL ABANDONED FASTENING, SUPPORT, BOXES AND CONDUCTORS TO THE SOURCE.
4. LABEL EXISTING PANELS TO REFLECT CHANGES MADE TO EXISTING ELECTRICAL SYSTEM.
5. MAINTAIN ALL FIRE AND LIFE SAFETY SYSTEMS IN AN OPERATIVE CONDITION AT ALL TIMES.

**ABBREVIATIONS**

- (E) EXISTING
- (ER) EXISTING TO REMAIN
- (ERD) REMOVE EXISTING
- (F) FUTURE
- (N) NEW
- (R) RECONNECT EXISTING

**BUILDING LEGEND**

- (B) BUS OPERATIONS
- (C) FISCAL RESOURCES/FAREBOX REPAIR
- (E) MINOR MAINTENANCE
- (F) ENERGY BUILDING & FUELING
- (G) OVERHAUL & REPAIR
- (H) FUEL ISLAND
- (K) ZEB MAINTENANCE SHOP
- (M) BUS WASH/WASTE WATER TREATMENT

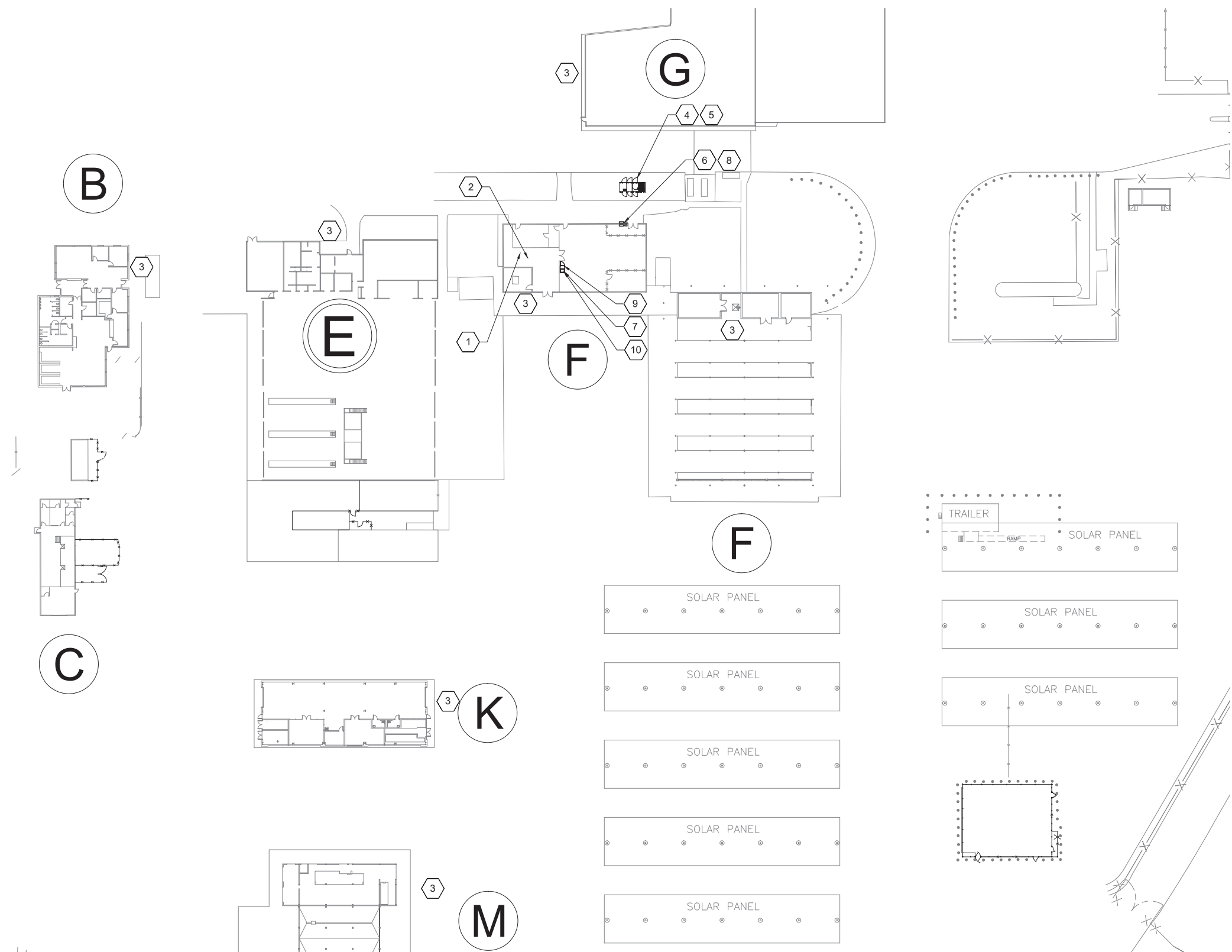

**ELECTRICAL SITE PLAN**

SCALE: 1" = 40'-0"

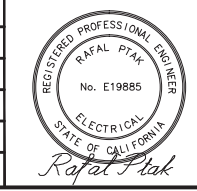

**BLMYER ENGINEERS**

DESIGNED RP CHECKED LM  
DRAWN RP CADD FILE NAME



APPROVED

CADD FILE DATE SCALE NONE  
PLOT DATE BOARD APPROVAL DATE

CERONE DIVISION  
EMERGENCY GENERATOR  
REPLACEMENT  
ELECTRICAL SITE PLAN

SHEET 16 OF 33 DRAWING NO. E-3.0 REVISION

SAP NO. CONTRACT NO. C19010 FILE LOCATION

NO.	DATE	REVISIONS
1		ISSUED FOR BID

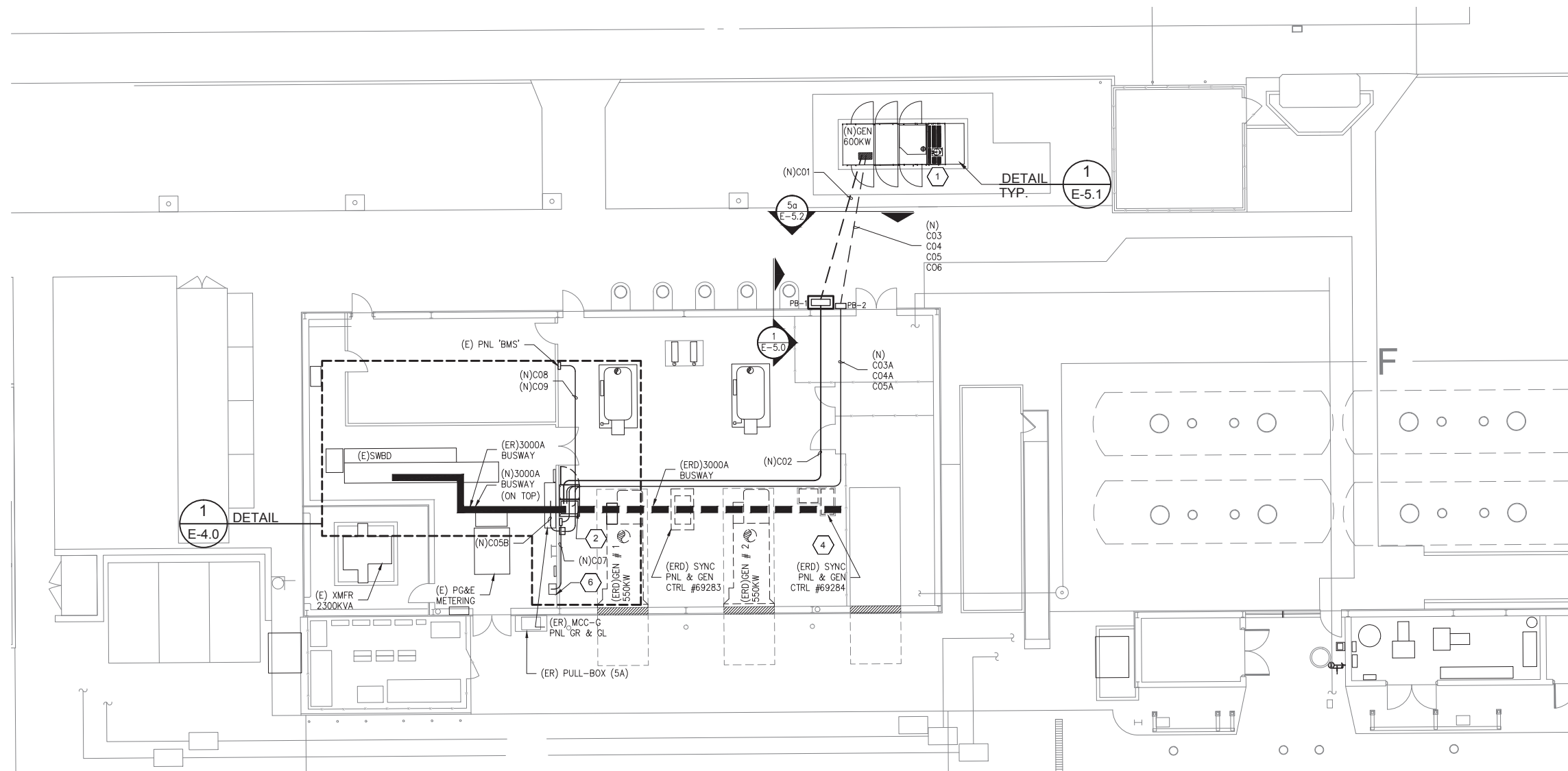

**GENERATOR ELECTRICAL SITE PLAN**  
SCALE: 1" = 10'-0"

**GENERAL NOTES**

1. ALL (N)EQUIPMENT SHALL BE UL LISTED AND APPROVED BY VTA.
2. WIRING SHALL BE INSTALLED IN APPROVED RACEWAYS FOR ITS INTENDED USE. ADEQUATELY STRAP AND SUPPORT ALL RACEWAYS. IN GENERAL SUPPORT ALL CONDUIT WITHIN THREE (3) FEET OF OUTLET BOX, PANEL OR ENCLOSURE AND MAXIMUM (10)TEN FEET ON CENTER THEREAFTER.
3. CONDUIT ROUTING IS DIAGRAMATIC ONLY, AND SHALL BE COORDINATED TO AVOID INTERFERENCES WITH OTHER UTILITIES/UNDERGROUND INSTALLATIONS. CONTRACTOR IS RESPONSIBLE FOR PERFORMING ALL VERIFICATION AND MAKING ALL NECESSARY OFFSETS AS REQUIRED.
4. INSTALLATION OF (N) EQUIPMENT SHALL FOLLOW MANUFACTURER INSTALLATION MANUAL RECOMMENDATION.
5. INSULATED CONDUCTORS INSTALLED IN WET LOCATION SHALL HAVE INSULATION RATED 600V, TYPE THHW, THWN, THWN-2, XHHW OR XHHW-2; THHN IS ALLOWED AT DRY AND DAMP LOCATION ONLY.
6. ALL ELECTRICAL TERMINATIONS SHALL BE PERFORMED USING THE PRESCRIBED MANUFACTURER'S WRITTEN INSTALLATION INSTRUCTIONS, INCLUDING ANY TORQUING VALUES IDENTIFIED THEREIN. WHERE TORQUE VALUES ARE NOT SPECIFIED, REFER TO UL STANDARDS 486A AND 486B. FINAL TORQUING SHALL BE OBSERVED BY VTA WITH DOCUMENTATION PROVIDED BY CONTRACTOR INDICATING THE TORQUE VALUE ATTAINED DURING INSTALLATION.
7. MECHANICAL EXCAVATORS AND BACKHOES ARE NOT ALLOWED FOR TRENCHING EXCAVATIONS, DUE TO (E) UNDERGROUND UTILITIES. USE HAND TOOLS TO EXCAVATE AROUND (E) UTILITIES "SOFT DIGGING" METHODS, INCLUDING THE USE OF AIR EXCAVATION EQUIPMENT MAY BE USED, SUBJECT TO PRIOR REVIEW AND APPROVAL BY VTA.

**KEYED NOTES**

1. STANDBY GENERATOR, CATERPILLAR C18 ACERT 600KW/750KVA, 60Hz, 1800rpm, 480VAC, 0.8 POWER FACTOR; OR EQUAL UNIT. REFER TO GENERATOR INSTALLATION MANUAL FOR CONDUIT/WIRES TERMINATION LOCATION, AND DESIGNATED GND POINTS; SEE GENERATOR GND PLAN ON SHEET E-5.1.
2. SPLIT EXISTING BUSWAY AND INSTALL DOWNWARD (N)ELBOW FLANGES TO ENTER THE (N)ATS ENCLOSURE; OR EXTEND TO ATS TERMINALS WITH EIGHT (8) 500 kcmil COPPER CABLES PER PHASE. FIELD COORDINATE EXACT ENCLOSURE PENETRATION LOCATION.
3. TOTAL QUANTITY AND SIZE OF THE WIRES FOR GENERATOR CTRL, AND THE AUXILIARY POWER. REFERENCES TO MANUFACTURER'S NAME AND MODEL NUMBER ARE USED TO ESTABLISH A QUALITY STANDARD FOR THIS PROJECT. IT IS UNDERSTOOD THAT SUCH REFERENCES ARE USED TO FACILITATE THE DESCRIPTION OF THE PRODUCT AND IS DEEMED TO BE FOLLOWED BY THE WORDS 'OR EQUAL'.
4. REMOVE SECTIONS OF EXISTING WESTINGHOUSE POW-R-WAY BUSWAY AND ASSOCIATED CONTROL CIRCUITS FOR EXISTING GENERATORS. OTHER CIRCUITS MUST STAY AS IT IS.
5. ALL CONDUITS/FEEDERS SHALL BE LABELED IN ACCORDANCE WITH THE CONDUIT SCHEDULE INCLUDING LOCATION WITHIN MANHOLES AND PULL-BOXES.
6. PROVIDE CONDUIT FOR RS485 COMMUNICATION CABLE, FROM ANN-1 PANEL TO FIBER OPTIC ENTRY POINT TO BUILDING 'F'. FROM THAT POINT, UTILIZE (E) CONDUIT TO RUN RS485 CABLE TO PANEL ANN-2 LOCATED IN SECURITY BUILDING. CONFIRM AND COORDINATE WITH VTA.

**ABBREVIATIONS**

- (E) EXISTING
- (ER) EXISTING TO REMAIN
- (ERD) REMOVE EXISTING
- (F) FUTURE
- (N) NEW
- (R) RECONNECT EXISTING

**(N) CONDUIT SCHEDULE**

ID	CONDUIT, WIRE SIZE	FROM	TO	CONDUIT TYPE/REMARKS
CO1	(3) 4", 4#600, 1#250GND	GENERATOR	PB-1	PVC COATED GRS
CO2	(3) 4", 4#600, 1#250GND	PB-1	(N)SWBD/ATS	GRS
CO3	1", 8#12	GENERATOR CTRL PANEL	PB-2	PVC COATED GRS
CO3A	1", 8#12	PB-2	ATS	GRS
CO4	1", 1-BELDEN #1063A (RS485), 2#12	GENERATOR CTRL PANEL	PB-2	PVC COATED GRS
CO4A	1", 1-BELDEN #1063A (RS485), 2#12	PB-2	ANNUNCIATOR PNL, ANN-1	GRS
CO5	1-1/2", 4#8, 4#10, 1#8GND	GENERATOR CTRL PANEL	PB-2	PVC COATED GRS
CO5A	1-1/2", 4#8, 4#10, 1#8GND	PB-2	(N)PNL 'PL-11'	GRS
CO5B	1", 2#8, 1#10GND	(N)PNL 'PL-11'	(E)SWBD "MCC-G"	GRS
CO6	2"	GENERATOR CTRL PANEL	PB-2	PVC COATED GRS (SPARE)
CO7	1", 1-BELDEN #1063A (RS485)	ANNUNCIATOR PNL, ANN-1	ANNUNCIATOR PNL, ANN-2	GRS (ONLY TO FO ENTRY POINT)
CO8	1" (SPARE)	ATS	PNL 'BMS'	GRS (FOR FUTURE WIRING, N.I.C)
CO9	1" (SPARE)	PNL "ANN-1"	PNL 'BMS'	GRS (FOR FUTURE WIRING, N.I.C)

**(N) PULL-BOX SCHEDULE**

ID	PULL-BOX SIZE	NEMA
PB-1	60"x38"x16"	4X
PB-2	36"x24"x12"	4X

		<p>SUBMITTED</p>		<p>APPROVED</p>	<p>CERONE DIVISION EMERGENCY GENERATOR REPLACEMENT GENERATOR ELECTRICAL SITE PLAN</p>	<p>SHEET 17 OF 33 DRAWING NO. <b>E-3.1</b> REVISION</p>
1	ISSUED FOR BID	DESIGNED RP	CHECKED LM	CADD FILE DATE	SCALE NONE	
NO.	DATE	DRAWN RP	CADD FILE NAME	PLOT DATE	BOARD APPROVAL DATE	SAP NO.
	REVISIONS				-	CONTRACT NO. C19010
						FILE LOCATION



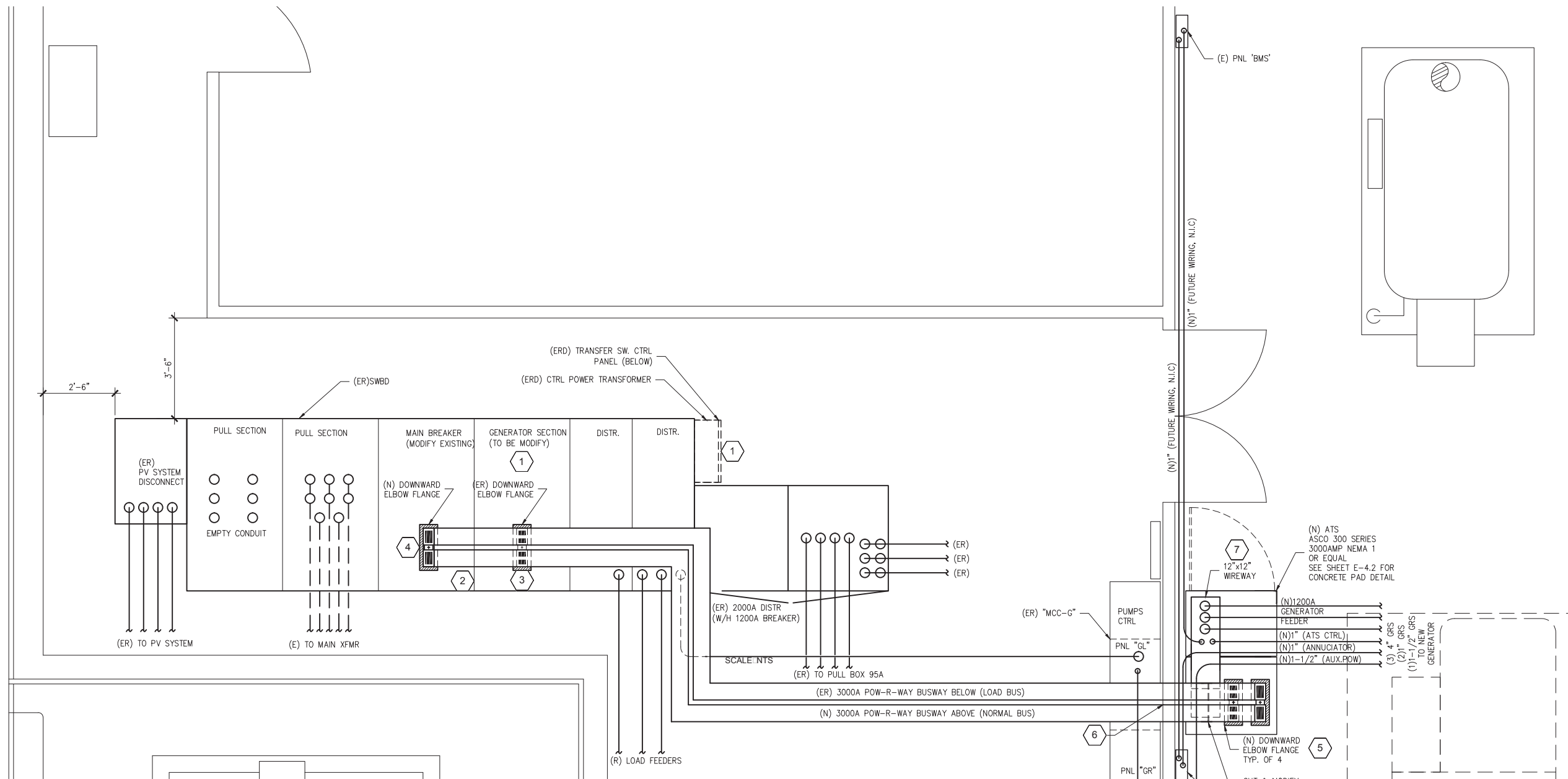

1 (E) ELECTRICAL SWBD (BY IEM) AND (N) ATS LAYOUT

**KEYED NOTES**

- 1 REMOVE EXISTING 3000 AMPS GENERATOR BREAKER AND AUTOMATIC THROWOVER CONTROLS.
- 2 REMOVE/DIVIDE BUSING IN THE LOWER SECTION OF EXISTING MSB SWBD BETWEEN EMERGENCY AND MAIN CIRCUIT BREAKER.
- 3 EXTEND 3000 AMPS (ER)BUS RISER IN THE GENERATOR SECTION TO THE LOWER/HORIZONTAL SECTION OF THE BUS AS REQUIRED. THIS BUS WILL BE SERVING AS A SWBD (ER)LOAD BUS.
- 4 PROVIDE NEW 3000A BUS RISER IN THE MAIN BREAKER COMPARTMENT FROM THE BUS IN THE LOWER SECTION, TO THE TOP OF MSB SWBD. INSTALL (N) EATON POW-R-WAY 3000A BUSWAY SYSTEM TO THE ATS. THIS BUS SHALL BE RUN ON THE TOP OF (ER)LOAD BUS, AND WILL BE SERVING AS A SWBD (N)NORMAL BUS.
- 5 PROVIDE DOWNWARD ELBOW FLANGES TO ENTER ATS ENCLOSURE. EXTEND TO ATS TERMINALS WITH EIGHT (8) 500 kcmil COPPER CABLES PER PHASE. CONTRACTOR TO FIELD VERIFY EXACT ENCLOSURE PENETRATION LOCATION.
- 6 RELOCATE EXISTING CONDUITS THAT PENETRATE THE WALL ABOVE (E)GENERATOR BUSWAY TO MAKE A SPACE FOR THE NEW NORMAL POWER BUS; AND/OR MAKE A TEMPORARY FLEXIBLE OVERRIDE CONNECTION FOR A CONDUITS/WIRING THAT ARE PART OF (E) GENERATORS SYSTEM TO BE REMOVED (AFTER INTERCONNECTION OF THE NEW GENERATOR).
- 7 PROVIDE 12"x12" WIREWAY SYSTEM TO INTERFACE CONDUIT INTO ATS ENCLOSURE.

**GENERAL NOTES**

- 1. CONDUITS SHOWN ARE DIAGRAMATIC. CONTRACTOR IS RESPONSIBLE FOR FIELD CHECKING AND VERIFYING LOCATION AND SIZES.
- 2. SEE SHEET E-4.4 FOR ADDITIONAL INFO NOT NOTED HERE, & SEQUENCE OF CONSTRUCTION.

**ABBREVIATIONS**

- (E) EXISTING
- (ER) EXISTING TO REMAIN
- (ERD) REMOVE EXISTING
- (F) FUTURE
- (N) NEW
- (R) RECONNECT EXISTING



**BLMYER ENGINEERS**

DESIGNED RP CHECKED LM  
DRAWN RP CADD FILE NAME



APPROVED	
CADD FILE DATE	SCALE NONE
PLOT DATE	BOARD APPROVAL DATE

**CERONE DIVISION  
EMERGENCY GENERATOR  
REPLACEMENT  
ELECTRICAL DETAILS**

SAP NO. CONTRACT NO. C19010 FILE LOCATION

SHEET 19
OF 33
DRAWING NO. <b>E-4.0</b>
REVISION

NO.	DATE	REVISIONS
1		ISSUED FOR BID

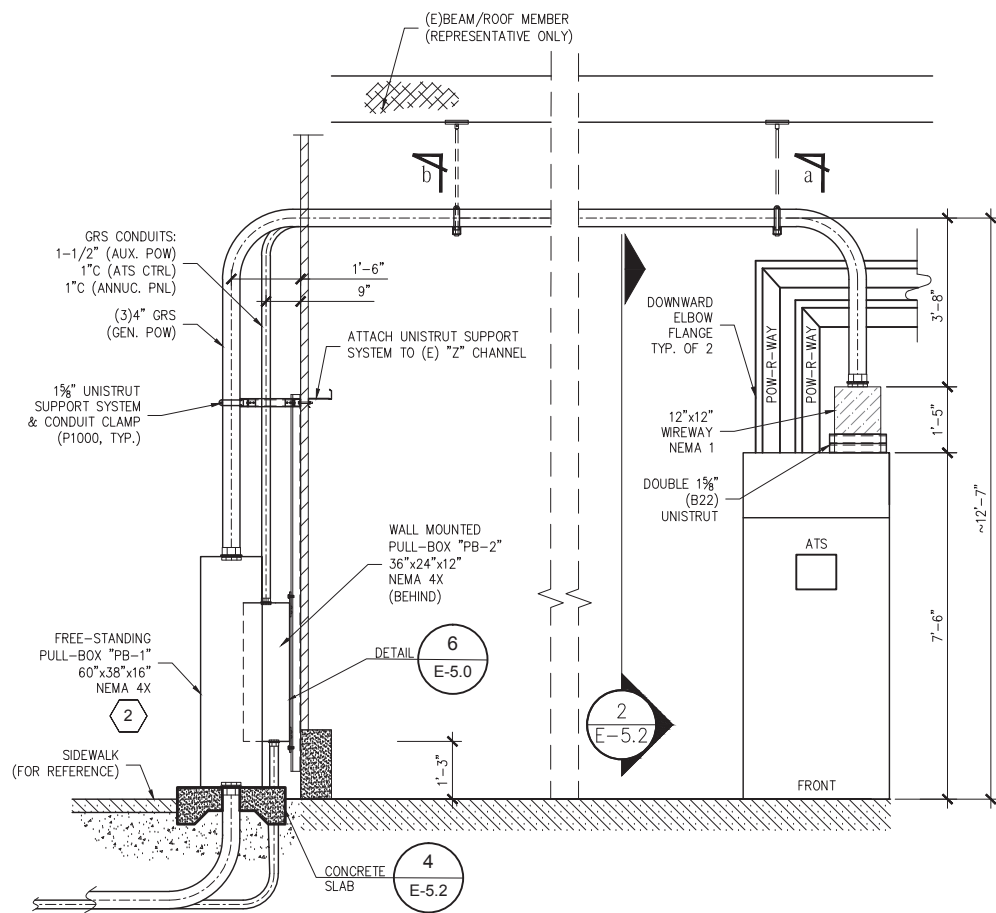

**1 GENERATOR FEEDER CONDUIT INSTALLATION**  
E-5.0 SCALE: NTS

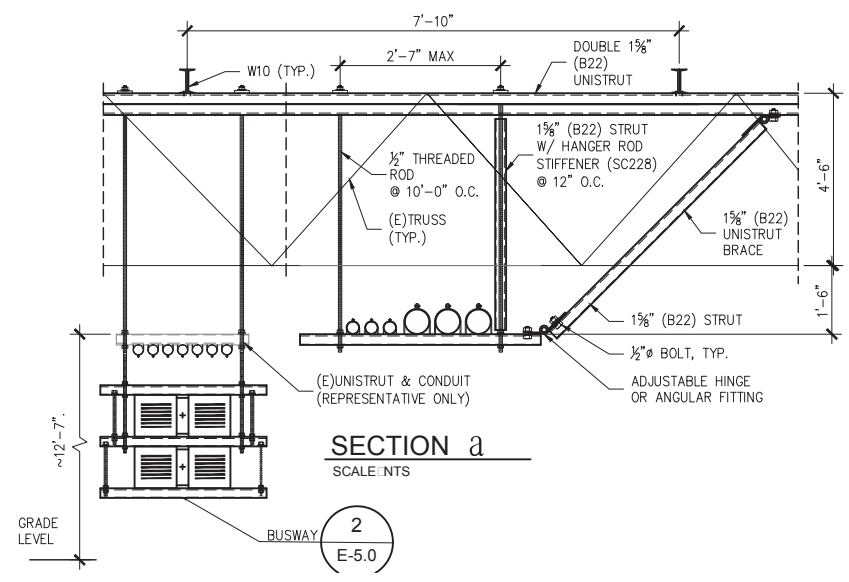

**2 BUSWAY ATTACHEMENT**  
E-5.0 SCALE: NTS

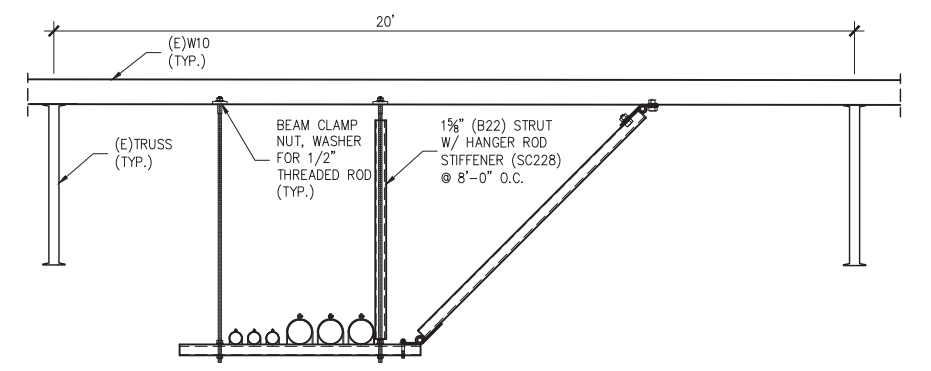

**6 PULL-BOX ATTACHEMENT**  
E-5.0 SCALE: NTS

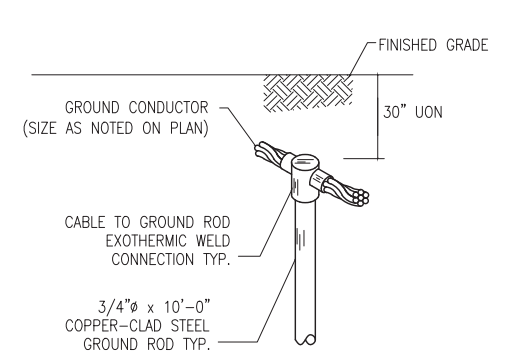

**3 GROUNDING ROD**  
E-5.0 SCALE: NTS

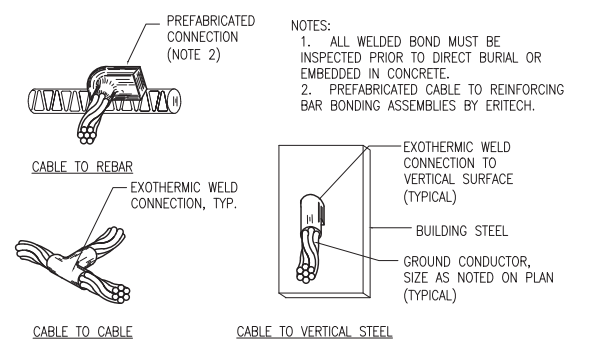

**4 EXOTHERMIC CONNECTION**  
E-5.0 SCALE: NTS

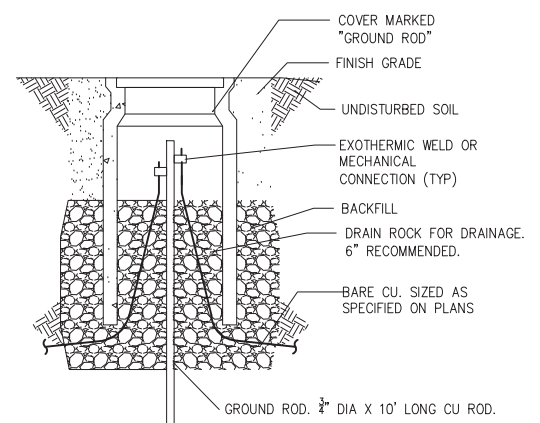

**5 GROUNDING WELL**  
E-5.0 SCALE: NTS

- INSTALLATION NOTES:**
- ANCHOR ELECTRICAL EQUIPMENT WITH HILTI KB-TZ STAINLESS STEEL ANCHOR BOLTS. INSTALLATION AND SPECIAL INSPECTION PER SECTION 4.3 AND 4.4 OF ICC REPORT ESR-1917.
  - ANCHOR BOLT INSTALLATION TORQUE:  
 3/8" - 40 LB.-FT. TORQUE  
 1/2" - 60 LB.-FT. TORQUE  
 5/8" - 110 LB.-FT. TORQUE

**GENERAL NOTES**

- EXPANSION ANCHOR, ANCHOR BOLTS, HARDWARE AND FASTENINGS, ETC, INSTALLED OUTDOORS SHALL BE STAINLESS STEEL.
- PAINTING REQUIREMENTS: REFER TO PAINT APPLICATION SCHEDULE, TS 09 91 23, PART 3.05 "APPLICATION SCHEDULE".

**KEYED NOTES**

- BUSWAY ATTACHMENT TO THE (E) ROOF MEMBERS SHALL BE AS CONDUITS SUPPORT SHOWN ON DETAIL "SECTION 'a'", IN INTERVALS AS NOTED.
- PROVIDE BULK FASTENING TERMINAL BLOCKS TO SPLICE THE CABLE INSIDE THE PULL BOX; MARATHON, PART #BFPD-50-2-3 OR EQUAL. WIRE BENDING SPACE AT TERMINALS SHALL BE PROVIDED IN ACCORDANCE WITH NEC TABLE 312.6(B).

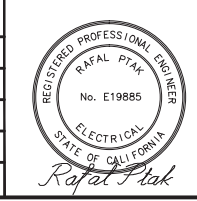

SUBMITTED

**BLMYER ENGINEERS**

DESIGNED RP CHECKED LM

DRAWN RP CADD FILE NAME



APPROVED

CADD FILE DATE SCALE NONE

PLOT DATE BOARD APPROVAL DATE

CERONE DIVISION  
EMERGENCY GENERATOR  
REPLACEMENT  
ELECTRICAL DETAILS

SHEET 24 OF 33 DRAWING NO. E-5.0 REVISION

SAP NO. CONTRACT NO. C19010 FILE LOCATION

NO.	DATE	REVISIONS
1		ISSUED FOR BID

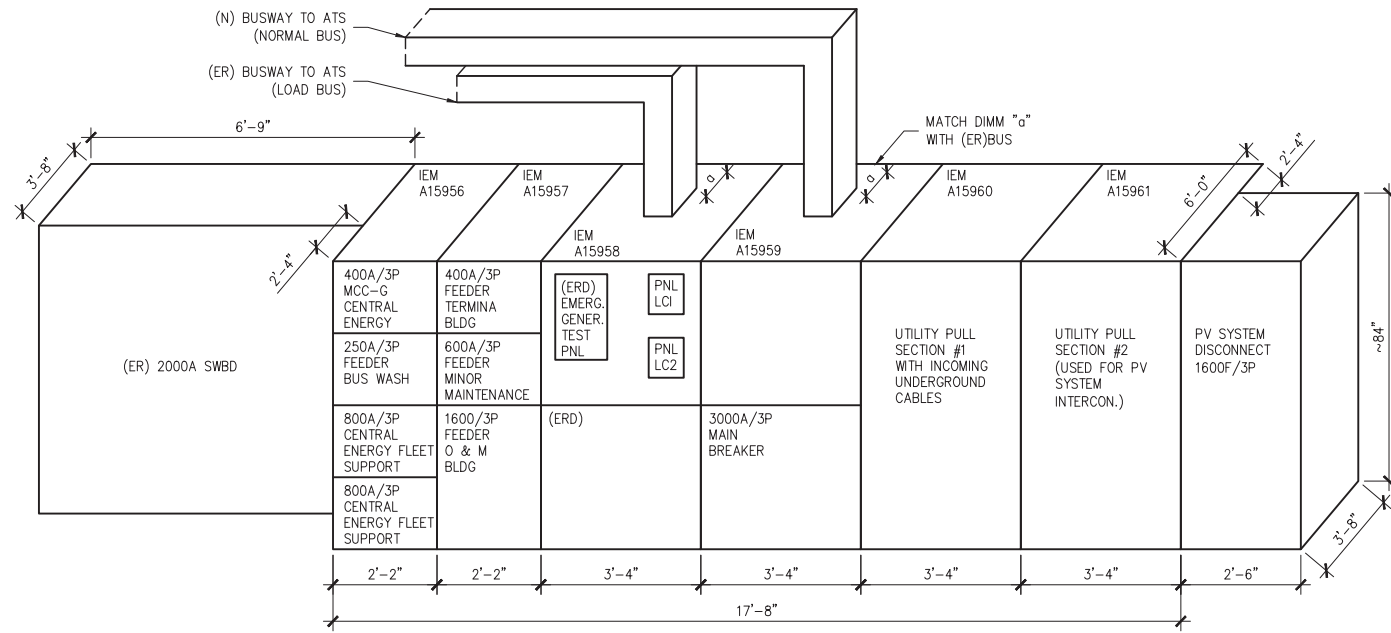

1 (E) ELECTRICAL SWBD ELEVATION (BY IEM) AFTER MODIFICATIONS  
E-5.2 SCALE: NTS

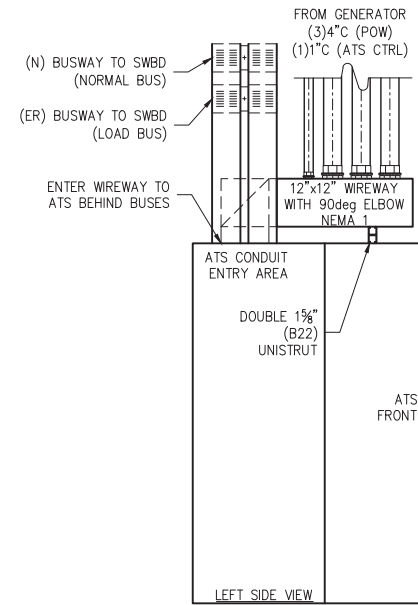

2 CONDUIT TO ATS ENTRANCE DETAIL  
E-5.2 SCALE: NTS

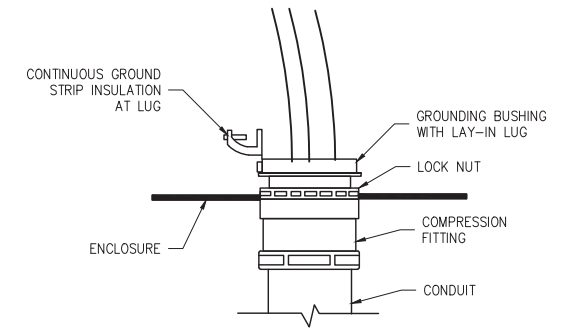

3 CONDUIT GROUNDING  
E-5.2 SCALE: NTS

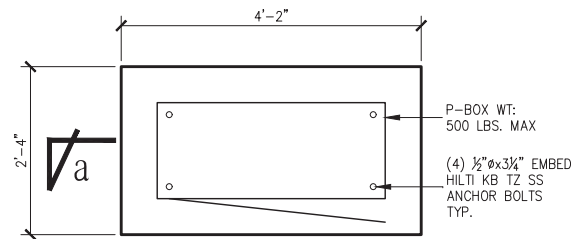

4 PULL-BOX "PB-1" CONCRETE PAD  
E-5.2 SCALE: NTS

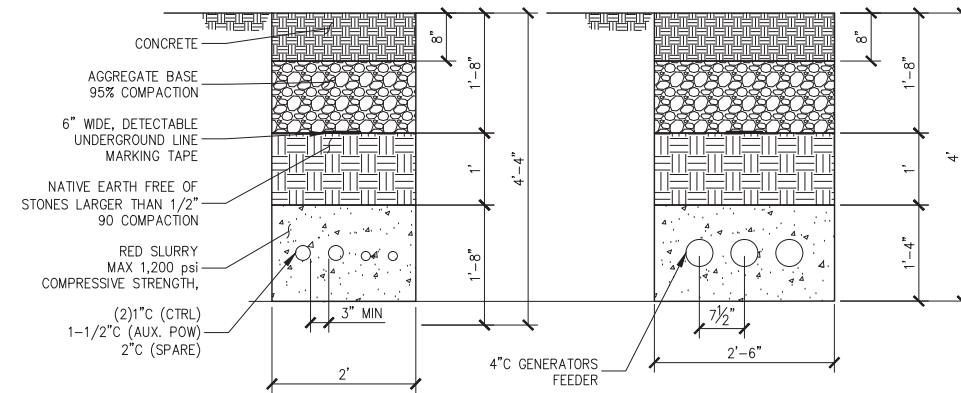

5a GENERATOR CONDUIT DUCKBANK  
E-5.2 SCALE: NTS

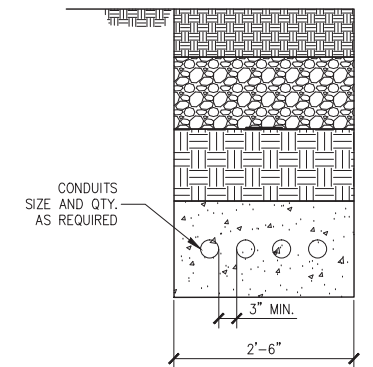

5b CONDUIT DUCKBANK, (TYP.)  
E-5.2 SCALE: NTS

**NOTES**

- FINAL PAD DIMENSIONS AND EQUIPMENT LOCATION TO BE DETERMINED PENDING ELECTRICAL EQUIPMENT SUBMITTALS
- REFER TO "S" SHEETS FOR GENERATOR SLAB.



**BLMYER ENGINEERS**

DESIGNED	RP	CHECKED	LM
DRAWN	RP	CADD FILE NAME	



**APPROVED**

CADD FILE DATE	SCALE
PLOT DATE	BOARD APPROVAL DATE

**CERONE DIVISION  
EMERGENCY GENERATOR  
REPLACEMENT  
ELECTRICAL DETAILS**

SAP NO.	CONTRACT NO. C19010	FILE LOCATION
---------	---------------------	---------------

NO.	DATE	REVISIONS
1		ISSUED FOR BID

SHEET 26
OF 33
DRAWING NO. <b>E-5.2</b>
REVISION

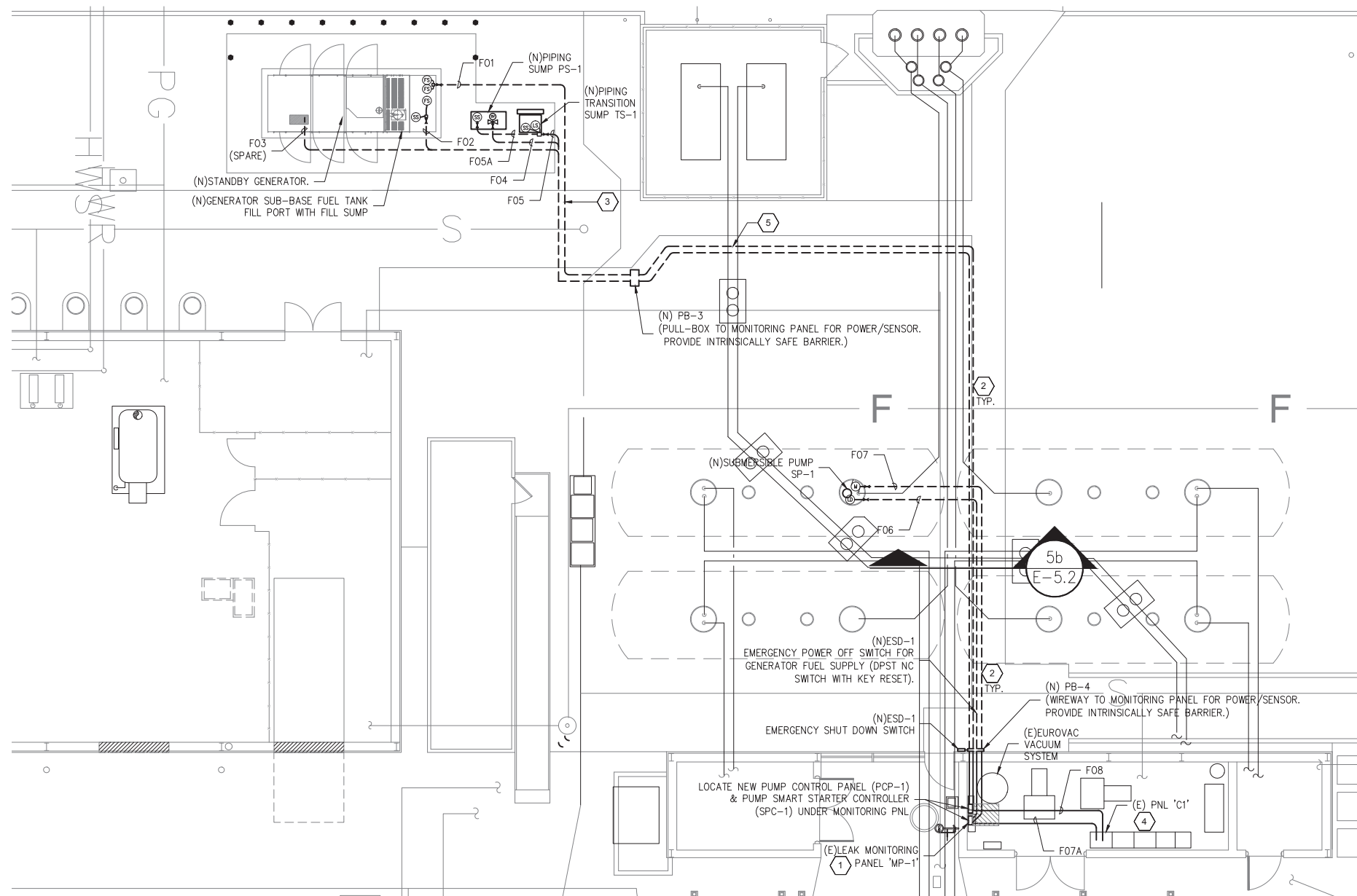

**GENERATOR FUELING ELECTRICAL PLAN**

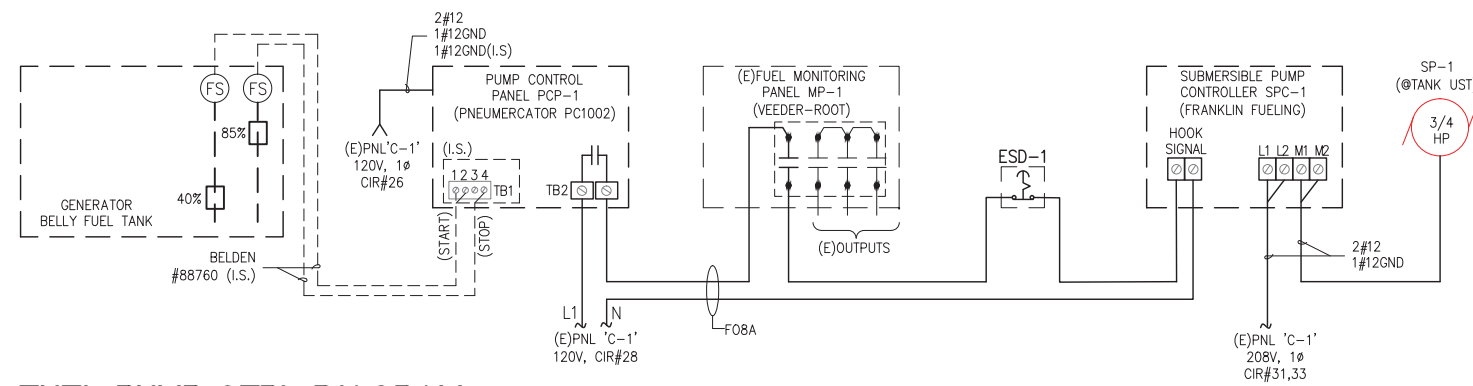

**FUEL PUMP CTRL DIAGRAM**

**GENERAL NOTES**

- MECHANICAL EXCAVATORS AND BACKHOES ARE NOT ALLOWED FOR TRENCHING EXCAVATIONS, DUE TO (E) UNDERGROUND UTILITIES. USE HAND TOOLS TO EXCAVATE AROUND (E) UTILITIES "SOFT DIGGING" METHODS, INCLUDING THE USE OF AIR EXCAVATION EQUIPMENT MAY BE USED, SUBJECT TO PRIOR REVIEW AND APPROVAL BY VTA.
- WHILE DIESEL FUEL IS A COMBUSTIBLE FUEL NOT REQUIRING A CLASS 1, DIV 2 INSTALLATION ALL CONDUITS AND WIRING SHALL BE INSTALL TO MEET THE REQUIREMENTS OF CLASS 1, DIV 2.

**KEYED NOTES**

- EXISTING MONITORING PANEL HAS ONLY TWO KNOCKOUTS, ONE FOR POWER AND ONE FOR INTRINSICALLY SAFE. CONSOLIDATE NEW CONDUITS AS NECESSARY TO ACCOMMODATE KNOCKOUTS.
- REMOVE AND REPLACE EXISTING CONCRETE PAVING AS NECESSARY TO PERFORM THE WORK SHOWN IN THIS AREA. DEMOLITION, SAW-CUTTING AND REMOVAL OF EXISTING CONCRETE, EXCAVATION AND OTHER REMOVALS SHALL BE DONE TO THE MINIMUM REQUIRED TO REMOVE EXISTING AND REPLACE WITH NEW. NEW CONCRETE SHALL MATCH EXISTING; REPAIRING ANY MARKINGS WHICH ARE DAMAGE TO MATCH EXISTING.
- REFER TO SH. D-1.0 FOR DEMOLITION, SAW-CUTTING AND REMOVALS OF EXISTING CONCRETE, EXCAVATION AND OTHER REMOVALS IN THIS AREA.
- PROVIDE NEW 20A/2P BREAKER FOR CIR#31,33; AND TWO (2)20A/1P FOR CIRCUITS #26 & 28. NEW BREAKER TYPE AND SHORT CIRCUIT RATING SHALL MATCH EXISTING, AND SHALL BE A TYPE APPROVED TO BE INSTALLED IN (E)PNL 'C1'. SEE MANUFACTURER INFORMATIONAL LABEL OR REFER TO CATALOG.
- UTILITY CROSSING AT DEPTH ~30" AND 36". RUN NEW CONDUITS UNDER, KEEP MIN 6" OF SEPARATION.

**SENSORS**

- (LS) LEAK SENSOR
- (SS) SUMP SENSOR
- (LD) LINE LEAK DETECTOR
- (FS) FLOAT SWITCH

**LEGEND**

- MIN. REQUIRED WORK SPACE AT FRONT OF THE EQUIPMENT 30"WIDE X 36"DEEP
- MUSHROOMED NC PUSHBUTTON LATCHING, MANUAL RESET

**ABBREVIATIONS**

- (E) EXISTING
- (ER) EXISTING TO REMAIN
- (ERD) REMOVE EXISTING
- (F) FUTURE
- (N) NEW
- (R) RECONNECT EXISTING

**(N) PULL-BOX SCHEDULE**

ID	PULL-BOX SIZE	NEMA	PART#/(REMARKS)
PB-3	11-3/4"x22-1	-	CHISTRY N16
PB-4	10"x10"x24"	4X	(WIREWAY)

**(N) FUELING SYSTEM CONDUIT SCHEDULE**

ID	CONDUIT, WIRE SIZE	FROM	TO	CONDUIT TYPE/REMARKS
F01	3/4", 2-BELDEN #88760	GENERATOR BELLY TANK	PNL PCP-1	PVC COATED GRS
F02	3/4", 2-BELDEN #88760	GENERATOR BELLY TANK	PNL MP-1	PVC COATED GRS
F03	1" (SPARE)	GENERATOR CTRL PANEL	TO MP-1 VIA PCP-1	PVC COATED GRS
F04	3/4", 2#12, 1#12GND	PIPING SUMP PS-1	PNL MP-1	PVC COATED GRS
F05	3/4", 3-BELDEN #88760	TRANSITION SUMP TS-1	PNL MP-1	PVC COATED GRS
F05A	3/4", 1-BELDEN #88760	PIPING SUMP PS-1	TRANSITION SUMP TS-1	PVC COATED GRS
F06	3/4", 1-BELDEN #88760	UNDERGROUND TANK/PUMP SP-1	PNL MP-1	PVC COATED GRS
F07	3/4", 2#12, 1#12GND	'SPC-1'	PUMP SP-1	PVC COATED GRS
F07A	3/4", 2#12, 1#12GND	(E)PNL 'C1'	'SPC-1'	GRS (CIR#31,33)
F08	3/4", 2#12, 2#12GND (I.S.); 2#12	(E)PNL 'C1'	'PCP-1'	GRS (CIR#26-POW) (CIR#28-CTRL LOOP)
F08A	3/4", 2#12, 1#12GND	'PCP-1'	'SPC-1'	GRS (CIR#28-CTRL LOOP)



			APPROVED CADD FILE DATE: _____ SCALE: NONE PLOT DATE: _____ BOARD APPROVAL DATE: _____	CERONE DIVISION EMERGENCY GENERATOR REPLACEMENT GENERATOR FUELING FUEL ELECTRICAL PLAN	SHEET 27 OF 33 DRAWING NO. FE-20 REVISION
	SUBMITTED DESIGNED RP DRAWN RP	CHECKED LM CADD FILE NAME	SAP NO. _____ CONTRACT NO. C19010 FILE LOCATION _____		

NO.	DATE	REVISIONS
1		ISSUED FOR BID

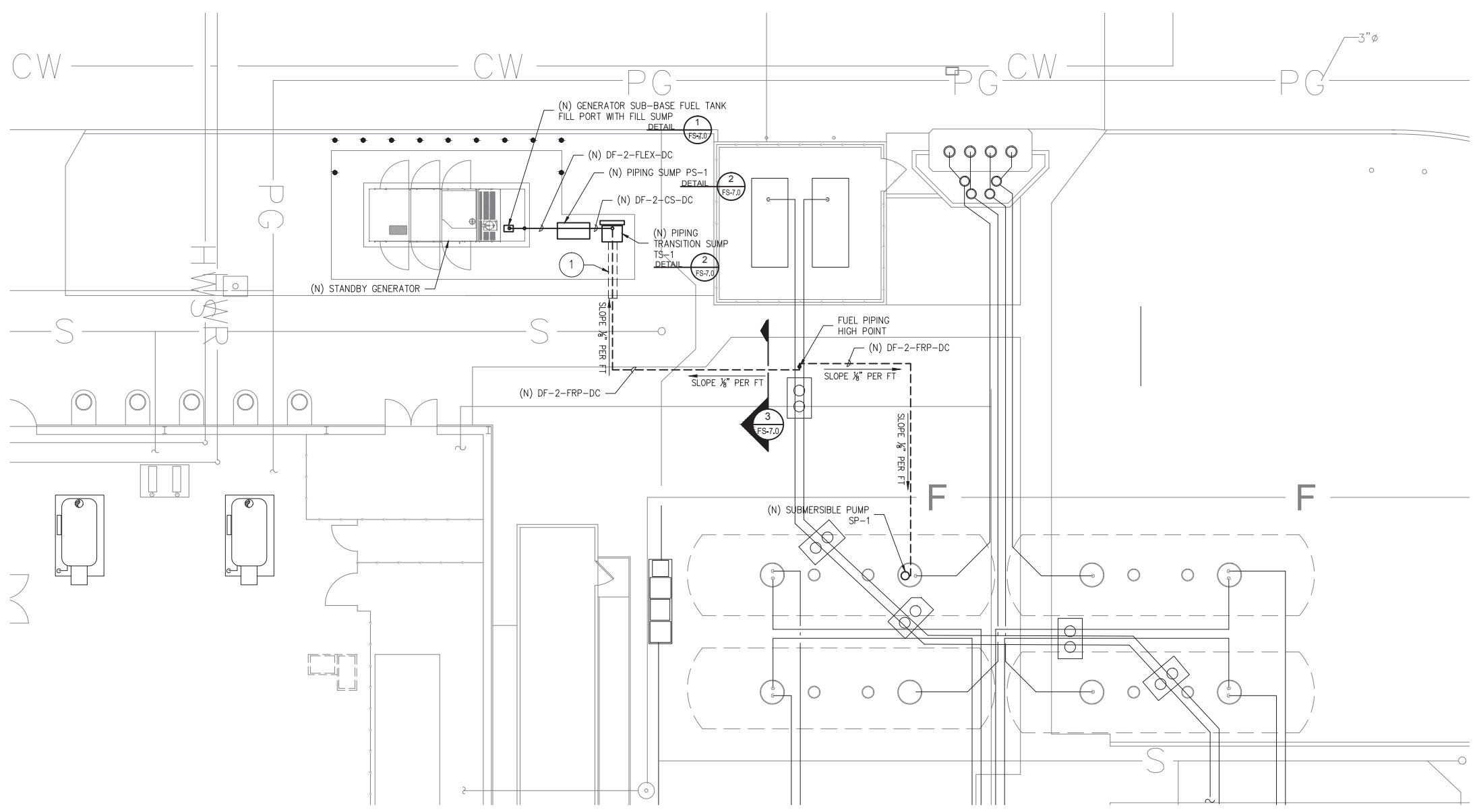

**LINE DESIGNATION**

- DF-2-FRP-DC
  - DOUBLE CONTAINED MATERIAL
  - CS - CARBON STEEL
  - CSG - CARBON STEEL GALVANIZED
  - FRP - FIBERGLASS REINFORCED PIPE
  - FLEX - FLEXIBLE PIPING
  - PRIMARY PIPING SIZE
  - SERVICE
  - DF - DIESEL FUEL

**SHEET NOTES:**

- 1 REFER TO SHEET D-1.0 FOR DEMOLITION, SAW-CUTTING AND REMOVAL OF EXISTING CONCRETE, EXCAVATION AND OTHER REMOVALS IN THIS AREA.

**GENERAL NOTES:**

- 1. MECHANICAL EXCAVATORS AND BACKHOES ARE NOT ALLOWED FOR TRENCH EXCAVATIONS, DUE TO (E) UNDERGROUND UTILITIES. USE HAND TOOLS TO EXCAVATE AROUND (E) UTILITIES. "SOFT DIGGING" METHODS, INCLUDING THE USE OF AIR EXCAVATION EQUIPMENT MAY BE USED, SUBJECT TO PRIOR REVIEW AND APPROVAL BY VTA.

**LEGEND:**

- (E) - EXISTING
- (N) - NEW

**GENERATOR FUELING PIPING PLAN**  
SCALE: 1/8" = 1'-0"  
NORTH

NO.	DATE	REVISIONS
1		ISSUED FOR BID



SUBMITTED	
<b>BLMYER ENGINEERS</b>	
DESIGNED RP	CHECKED LM
DRAWN RP	CADD FILE NAME



APPROVED	
CADD FILE DATE	SCALE NONE
PLOT DATE	BOARD APPROVAL DATE

CERONE DIVISION EMERGENCY GENERATOR REPLACEMENT GENERATOR FUELING FUEL PIPING PLAN			SHEET 28 OF 33 DRAWING NO. <b>FS-2.0</b> REVISION
SAP NO.	CONTRACT NO. C19010	FILE LOCATION	



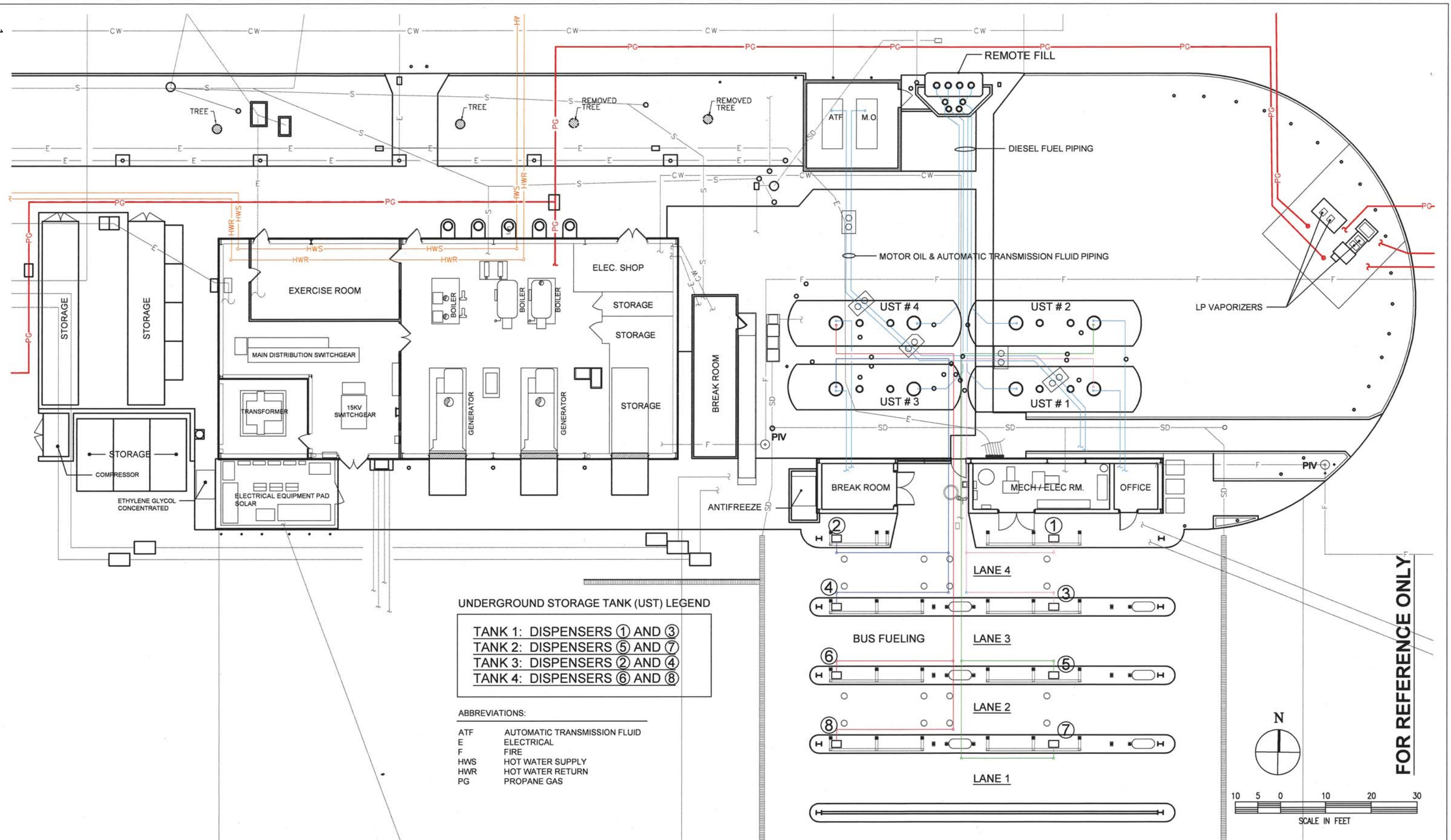

**UNDERGROUND STORAGE TANK (UST) LEGEND**

- TANK 1: DISPENSERS ① AND ③
- TANK 2: DISPENSERS ⑤ AND ⑦
- TANK 3: DISPENSERS ② AND ④
- TANK 4: DISPENSERS ⑥ AND ⑧

- ABBREVIATIONS:**
- ATF AUTOMATIC TRANSMISSION FLUID
  - E ELECTRICAL
  - F FIRE
  - HWS HOT WATER SUPPLY
  - HWR HOT WATER RETURN
  - PG PROPANE GAS

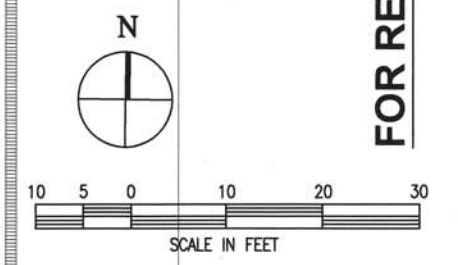
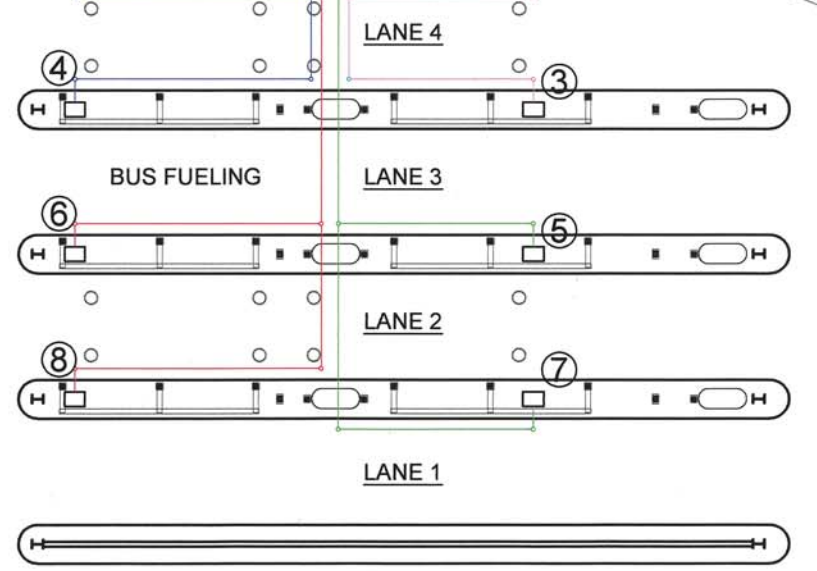

**FOR REFERENCE ONLY**

NO.	DATE	REVISIONS
1		ISSUED FOR BID



SUBMITTED	
DESIGNED	JO
CHECKED	JO
DRAWN	JO
	CADD FILE NAME



APPROVED	
CADD FILE DATE	SCALE 1" = 10'
PLOT DATE	BOND APPROVAL DATE

**CERONE DIVISION  
EMERGENCY GENERATOR  
REPLACEMENT  
EXISTING SITE PLAN**

SHEET 32 OF 33	DRAWING NO. R-1.0	REVISION
BAP NO.	CONTRACT NO. C19010	FILE LOCATION



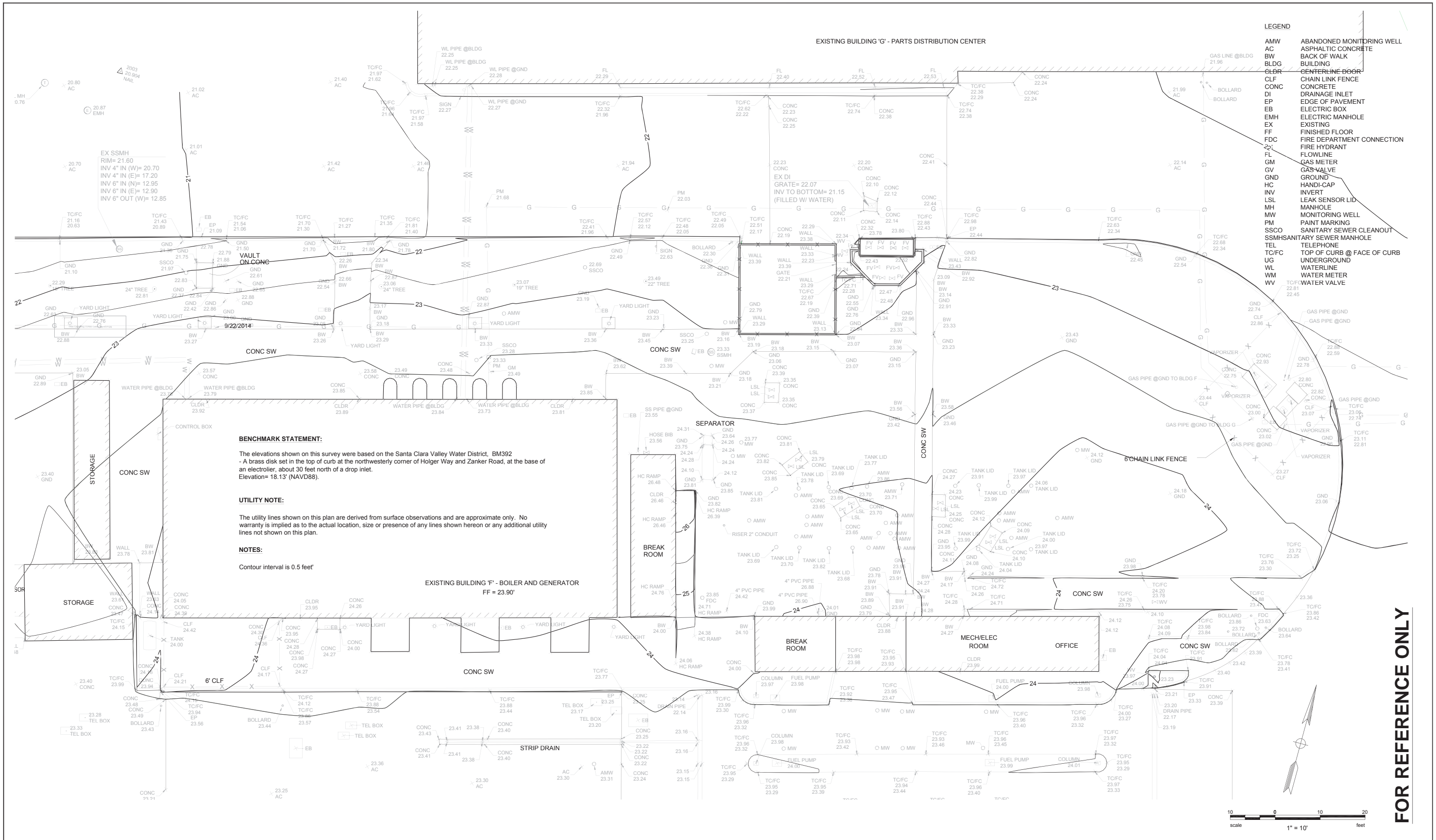

**LEGEND**

AMW	ABANDONED MONITORING WELL
AC	ASPHALTIC CONCRETE
BW	BACK OF WALK
BLDG	BUILDING
CLDR	CENTERLINE DOOR
CLF	CHAIN LINK FENCE
CONC	CONCRETE
DI	DRAINAGE INLET
EP	ELECTRIC BOX
EB	EDGE OF PAVEMENT
EMH	ELECTRIC MANHOLE
EX	EXISTING
FF	FINISHED FLOOR
FDC	FIRE DEPARTMENT CONNECTION
FV	FIRE HYDRANT
FL	FLOWLINE
GM	GAS METER
GV	GAS VALVE
GND	GROUND
HC	HANDI-CAP
INV	INVERT
LSL	LEAK SENSOR LID
MH	MANHOLE
MW	MONITORING WELL
PM	PAINT MARKING
SSCO	SANITARY SEWER CLEANOUT
SSMHS	SANITARY SEWER MANHOLE
TEL	TELEPHONE
TC/FC	TOP OF CURB @ FACE OF CURB
UG	UNDERGROUND
WL	WATERLINE
WM	WATER METER
WV	WATER VALVE

**BENCHMARK STATEMENT:**  
 The elevations shown on this survey were based on the Santa Clara Valley Water District, BM392 - A brass disk set in the top of curb at the northwesterly corner of Holger Way and Zanker Road, at the base of an electrical, about 30 feet north of a drop inlet. Elevation= 18.13' (NAVD88).

**UTILITY NOTE:**  
 The utility lines shown on this plan are derived from surface observations and are approximate only. No warranty is implied as to the actual location, size or presence of any lines shown hereon or any additional utility lines not shown on this plan.

**NOTES:**  
 Contour interval is 0.5 feet'

**FOR REFERENCE ONLY**

NO.	DATE	ISSUED FOR BID	REVISIONS
1			

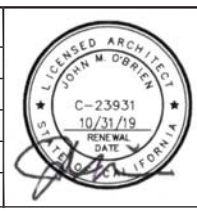

SUBMITTED	
DESIGNED	JO
CHECKED	JO
DRAWN	JO
CADD FILE NAME	20070065-50



APPROVED	
CADD FILE DATE	SCALE
FLOT DATE	BOARD APPROVAL DATE

SAP NO.	CONTRACT NO.	FILE LOCATION
	C19010	

**CERONE DIVISION  
 BOILER AND PROPANE TANK  
 REPLACEMENT  
 TOPOGRAPHIC SURVEY**

SHEET	33
OF 33	
DRAWING NO.	R-1.1
REVISION	

## **APPENDIX Q**

# **GUIDELINES FOR PREPARATION OF INJURY AND ILLNESS PREVENTION PROGRAM (IIPP) AND SITE SPECIFIC SAFETY PLAN (SSSP)**

As a prerequisite to issuance of Notice to Proceed (NTP), Contractor is required to submit various documents to VTA pursuant to Contract Section 2.3.4 – Executed Contract and Notice to Proceed. Two of the documents required are:

- Prime Contractor’s Injury and Illness Prevention Program (IIPP), and
- A Site Specific Safety Plan (SSSP).

NTP will not be issued to Contractor until Contractor submits a copy of their IIPP. The Injury and Illness Prevention Program plan and procedures must be in accordance with Section 3203 of the General Industry Safety Orders.

Additionally, NTP will not be issued until Contractor’s SSSP has been reviewed by VTA and returned as either NET or MCN, as those terms are defined in Section 6.6.2.

Contractor’s Site Specific Safety Plan, at a minimum, must address all areas enumerated in the attached VTA SSSP review checklist, be custom tailored to the specific project and work site conditions. Items or areas not applicable to this project must be noted as such.

- Contractor’s SSSP must identify the competent individual, or individuals, who will be responsible for Worksite safety. SSSP must certify that the competent individual(s) have received competent person training in all aspects of the Work, or list any specific exclusions for which a particular individual is not qualified to serve as a competent person. All aspects of the Work must be overseen by a competent person responsible for Worksite safety. Contractor must submit qualifications and certifications of individual(s) responsible for worksite safety within seven days of request by VTA.
- The list of hazardous substances / dangerous goods, may be limited to the main chemicals and substances anticipated to be utilized in the prosecution of the Work. Safety Data Sheets (SDS) may be incorporated in lieu of descriptive responses. Contractor’s attention is directed to Contract Section 6.14.3 – Safety Data Sheets and Hazardous Substances, which sets forth further requirements for the submittal of SDS for all materials brought on site.
- Contractor’s SSSP must address any site or project specific safety issues or hazards not addressed in the IIPP.
- Contractor’s SSSP must also include a map showing the route from the job site to the nearest emergency medical facility.

*[This Page Intentionally Left Blank]*

## IIPP Plans and Procedures Checklist

Requirement	Regulation	Page Number	Requirement Present (Y/N)	Comments
<b>1. Injury and Illness Prevention Program</b> <ul style="list-style-type: none"> <li>a. Safe Work Practices (training and discipline)</li> <li>b. Identifying Hazards</li> <li>c. Accident Prevention Program (inspections and safety committees)</li> </ul>	CCR T8 3203			
<b>2. Hazard Communication</b> <ul style="list-style-type: none"> <li>a. List of hazardous chemicals</li> <li>b. Safety Data Sheets</li> <li>c. Methods of informing employees of chemicals</li> <li>d. Multi-employer workplaces</li> <li>e. Employee information and training</li> </ul>	CCR T8 5194			
<b>3. Emergency Action Plan</b> <ul style="list-style-type: none"> <li>a. Evacuation routes</li> <li>b. How will employees be notified of alarms?</li> <li>c. Training</li> </ul>	CCR T8 3220			
<b>4. Lockout/Tagout Procedures</b> <ul style="list-style-type: none"> <li>a. Repair work and setting up</li> <li>b. Materials and hardware – employer approved locks</li> <li>c. Repetitive process machines</li> <li>d. Hazardous energy controls procedure</li> <li>e. Group LOTO procedures</li> <li>f. Shift or personnel changes</li> <li>g. Inspections</li> <li>h. Training</li> </ul>	CCR T83314			
<b>5. Heat Illness Prevention Plan</b> <ul style="list-style-type: none"> <li>a. Access to shade</li> <li>b. High-heat procedures</li> <li>c. Emergency response procedures</li> <li>d. Acclimatization</li> <li>e. Training</li> </ul>	CCR T8 3395			
<b>6. Safety Instructions to Employees</b> <ul style="list-style-type: none"> <li>a. Only qualified employees can operate machinery</li> </ul>	CCR T8 1510			

<ul style="list-style-type: none"> <li>b. How are employees made aware of job hazards?</li> </ul>				
<ul style="list-style-type: none"> <li><b>7. Respiratory Protection Plan</b></li> <li>a. Procedures for selecting a respirator</li> <li>b. Job descriptions/functions that may require a respirator</li> <li>c. Medical evaluations</li> <li>d. Fit testing procedures</li> <li>e. Proper use (cleaning, storage)</li> <li>f. Supplied air respirator procedures</li> <li>g. Training</li> <li>h. Program evaluation</li> </ul>	<p>CCR T8 5144</p>			
<ul style="list-style-type: none"> <li><b>8. Confined Spaces</b></li> <li>a. Operating Procedures/Employee training</li> <li>b. Pre-Entry</li> <li>c. Confined space operation</li> </ul>	<p>CCR T8 5157/5158</p>			

## Site Specific Safety Plan (SSSP) Checklist

Requirement	Page Number	Requirement Present (Y/N)	Comments
<p><b>1. Hazards Present at the Work Site</b></p> <ul style="list-style-type: none"> <li>a. Falls from heights</li> <li>b. Material Handling</li> <li>c. Trench Activity</li> <li>d. Scaffolding Activity</li> <li>e. Electric Shock and ARC Flash/Blast</li> <li>f. Excavation Activity</li> <li>g. Hazardous Chemicals</li> <li>h. Noise Exposure</li> <li>i. Airborne Contaminates and Dust</li> <li>j. Confined Spaces (Permitted and Non-Permitted)</li> <li>k. Cranes</li> <li>l. Powered Industrial Trucks</li> <li>m. Ergonomics</li> <li>n. Fire Prevention</li> <li>o. Hot Surfaces</li> </ul>			
<p><b>2. VTA Notification Procedure</b></p> <ul style="list-style-type: none"> <li>a. How will VTA be notified in the event a hazardous condition arises</li> </ul>			
<p><b>3. List of Hazardous Substances/Dangerous Goods</b></p> <ul style="list-style-type: none"> <li>a. Chemical name</li> <li>b. Hazards associated with the chemical name</li> <li>c. Quantity of each chemical</li> <li>d. Proper storage</li> <li>e. Inspection of storage areas</li> <li>f. Spill clean-up and reporting procedures</li> <li>g. Employee Training</li> </ul>			
<p><b>4. Toolbox Safety Meetings</b></p> <ul style="list-style-type: none"> <li>a. How often are safety meetings conducted?</li> <li>b. Who is required to attend?</li> <li>c. How are the meeting attendees documented?</li> <li>d. How is the information documented?</li> </ul>			



e. Where are these documents stored?			
<b>5. Prestart Site Assessment and Self-Safety Inspection Checklist</b> a. When is this conducted? b. How often is the checklist completed? c. Who completes these? d. How is this documented? e. Where is this information stored?			
<b>6. Emergency Plan for Hazardous Work</b>			
7. Emergency Evacuation Plan/Rescue Plan (Trenching) a. Evacuation Procedures b. Reporting Procedures c. Communication of rescue plans (trenching)			
<b>8. Accident/Incident/Near Miss Documentation and Reporting</b> a. How is an accident/incident/near miss investigated? b. What are the procedures? c. What forms are used? d. How are these forms stored? e. How will VTA be notified? f. What is the nearest hospital to the work site? g. Cal OSHA Reporting information			
<b>9. Safety Training</b> a. Who delivers the safety trainings? b. Who is required to attend? c. How is the training documented? d. How is knowledge tested? e. What topics are covered?			
<b>10. Site Induction Procedure</b> a. All documentation on how employees will be introduced to the work site and potential hazards are evaluated			
<b>11. SSSP Evaluation</b> a. When will the SSSP be evaluated? b. If amendments are needed how is VTA notified?			

## **APPENDIX R**

### **EXISTING UTILITIES INFORMATION**

All information is provided as reference information only. Accuracy of information is not guaranteed. Site conditions may have changed since the survey information was compiled. Contractor must field verify all utility information, follow all safe dig practices and comply with California Government Code 4216 requirements.

*[This Page Intentionally Left Blank]*

BKF No. 20180602-50  
APRIL 11, 2018

**Subject: VTA Cerone Yard  
UTILITY LOCATING SERVICES**

BKF utility locating crew went out to the VTA Cerone yard on different dates to do a utility locate. On the first day the crew meet with John Obrian and Mohamed Basma on site and went over the scope of work. John showed the crew the areas where they plan on doing work. John and the crew both agreed to the change of scope that way the crew could focus more on where they are planning on digging. The crew located multiple high voltage lines between 7-10 lines, and multiple communication lines between 7-10 lines. They located site light, propane gas lines, water lines and electrical lines. The crew located capped propane gas lines near the propane tank and when they did mag scans they got a high metal reading near the perimeter of the lot. They also located the sewer throughout the scope in some sewer lines they could not push past a certain area. At the end the crew performed passive scans and GPR work. They found 3 things with the GPR and got a radio signal. The crew could not get a signal off of any water valve or PIV and fire hydrant. They could also not see some utilities that they marked while using the GPR. The crew was not able to locate the fiberglass fuel lines and where not able to locate all possibly abandon lines. The crew was not able to locate some sewer lines due to not having access to the pipe or being able to see the line inside a manhole. The storm drains all had environmental protection grates/mesh and the crew was not able to locate them.



































GTS Junction

GPR

GPR2

GPR3

NO PARKING  
NO DELIVERIES  
NO PICKUPS

STOP

LOADING

STOP

Radon  
Sign  
100% CHM

SL-10  
Sign

H.V.P.

FILE

FILE

FILE

FILE

FILE

FILE

FILE

FILE

FILE

FILE

FILE

FILE

FILE

FILE

FILE

FILE

FILE

FILE

FILE

FILE

FILE

FILE

FILE

FILE

FILE

FILE

FILE

FILE

FILE

FILE

FILE

FILE

FILE

FILE

FILE

FILE

FILE

FILE

FILE

FILE

FILE

FILE

FILE

FILE

FILE

FILE

FILE

FILE

FILE

FILE

FILE

FILE

FILE

FILE

FILE

FILE

FILE

FILE

FILE

FILE

FILE

FILE

FILE

FILE

FILE

FILE

FILE

FILE

FILE

FILE

FILE

FILE

FILE

FILE

FILE

FILE

FILE

FILE

FILE

FILE

FILE

FILE

FILE

FILE

FILE

FILE

FILE

FILE

FILE

FILE

FILE

FILE

FILE

FILE

FILE

FILE

FILE

FILE

FILE

FILE

FILE

FILE

FILE

FILE

FILE

FILE

FILE

FILE

FILE

FILE

FILE

FILE

FILE

FILE

FILE

FILE

FILE

FILE

FILE

FILE

FILE

FILE

FILE

FILE

FILE

FILE

FILE

FILE

FILE

FILE

FILE

FILE

FILE

FILE

FILE

FILE

FILE

FILE

FILE

FILE

FILE

FILE

FILE

FILE

FILE

FILE

FILE

FILE

FILE

FILE

FILE

FILE

FILE

FILE

FILE

FILE

FILE

FILE

FILE

FILE

FILE

FILE

FILE

FILE

FILE

FILE

FILE

FILE

FILE

FILE

FILE

FILE

FILE

FILE

FILE

FILE

FILE

FILE

FILE

FILE

FILE

FILE

FILE

FILE

FILE

FILE

FILE

FILE

FILE

FILE

FILE

FILE

FILE

FILE

FILE

FILE

FILE

FILE

FILE

FILE

FILE

FILE

FILE

FILE

FILE

FILE

FILE

FILE

FILE

FILE

FILE

FILE

FILE

FILE

FILE

FILE

FILE

FILE

FILE

FILE

FILE

FILE

FILE

FILE

FILE

FILE

FILE

FILE

FILE

FILE

FILE

FILE

FILE

FILE

FILE

FILE

FILE

FILE

FILE

FILE

FILE

FILE

FILE

FILE

FILE

FILE

FILE

FILE

FILE

FILE

FILE

FILE

FILE

FILE

FILE

FILE

FILE

FILE

FILE

FILE

FILE

FILE

FILE

FILE

FILE

FILE

FILE

FILE

FILE

FILE

FILE

FILE

FILE

FILE

FILE

FILE

FILE

FILE

FILE

FILE

FILE

FILE

FILE

FILE

FILE

FILE

FILE

FILE

FILE

FILE

FILE

FILE

FILE

FILE

FILE

FILE

FILE

FILE

FILE

FILE

FILE



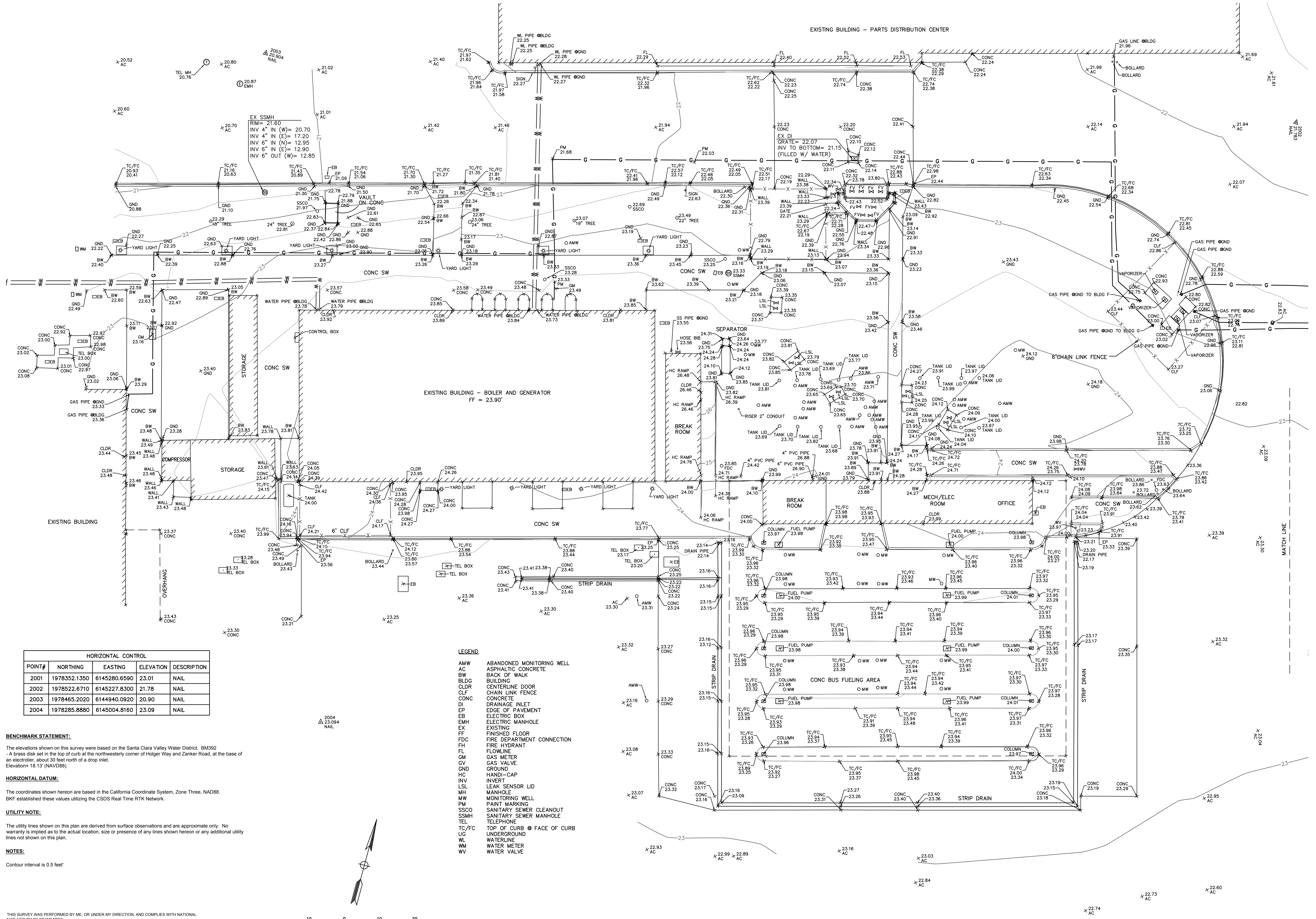
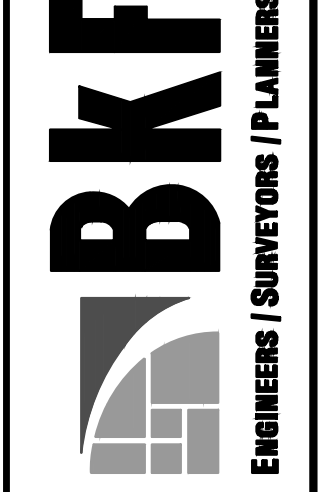

POINT#	NORTHING	EASTING	ELEVATION	DESCRIPTION
2001	1978352.1350	6145280.6590	23.01	NAIL
2002	1978522.6710	6145227.8300	21.78	NAIL
2003	1978465.2020	6144940.0920	20.90	NAIL
2004	1978285.8880	6145004.8160	23.09	NAIL

- LEGEND**
- AMW ABANDONED MONITORING WELL
  - AC ASPHALTIC CONCRETE
  - BW BACK OF WALK
  - BLDG BUILDING
  - CLDR CENTERLINE DOOR
  - CLF CHAIN LINK FENCE
  - CONC CONCRETE
  - DI DRAINAGE INLET
  - EP EDGE OF PAVEMENT
  - EB ELECTRIC BOX
  - EMH ELECTRIC MANHOLE
  - EX EXISTING
  - FF FINISHED FLOOR
  - FDC FIRE DEPARTMENT CONNECTION
  - FH FIRE HYDRANT
  - FL FLOWLINE
  - GM GAS METER
  - GV GAS VALVE
  - GND GROUND
  - HC HANDI-CAP
  - INV INVERT
  - LSL LEAK SENSOR LID
  - MH MANHOLE
  - MW MONITORING WELL
  - PM PAINT MARKING
  - SSCO SANITARY SEWER CLEANOUT
  - SSMH SANITARY SEWER MANHOLE
  - TEL TELEPHONE
  - TC/FC TOP OF CURB @ FACE OF CURB
  - UG UNDERGROUND
  - WL WATERLINE
  - WM WATER METER
  - WV WATER VALVE

**BENCHMARK STATEMENT:**  
The elevations shown on this survey were based on the Santa Clara Valley Water District, BM392 - A brass disk set in the top of curb at the northwesterly corner of Holger Way and Zanker Road, at the base of an electrolyser, about 30 feet north of a drop inlet. Elevation: 18.13' (NAVD88).

**HORIZONTAL DATUM:**  
The coordinates shown hereon are based in the California Coordinate System, Zone Three, NAD88. BKF established these values utilizing the CSDS Real Time RTK Network.

**UTILITY NOTE:**  
The utility lines shown on this plan are derived from surface observations and are approximate only. No warranty is implied as to the actual location, size or presence of any lines shown hereon or any additional utility lines not shown on this plan.

**NOTES:**  
Contour interval is 0.5 feet'

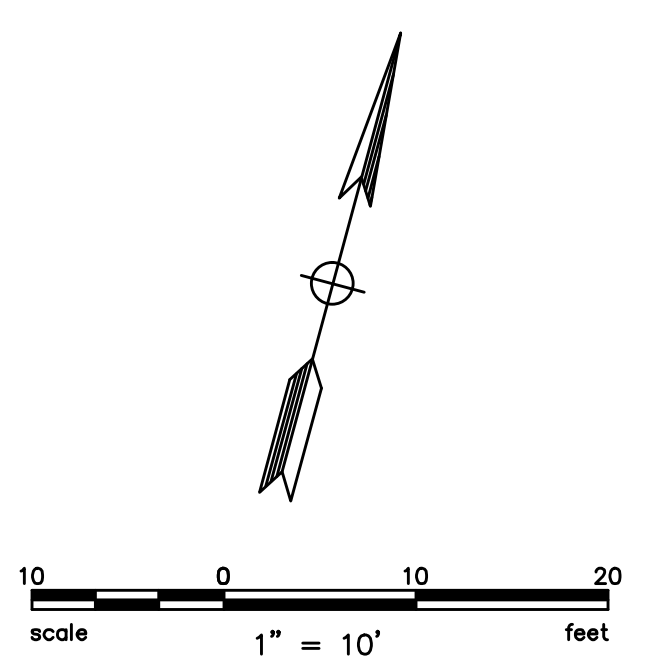

THIS SURVEY WAS PERFORMED BY ME, OR UNDER MY DIRECTION, AND COMPLIES WITH NATIONAL MAP ACCURACY STANDARDS.

ALEX M. CALDER  
P.L.S. 8863

9/22/2014  
DATE

STATE OF CALIFORNIA  
ALEX M. CALDER  
L.S. 8863





TOPOGRAPHIC SURVEY  
CERONE PROPANE TANK, BOILER & EMERGENCY GENERATOR  
(VTA SR NO. 3835 / T.O. 33)

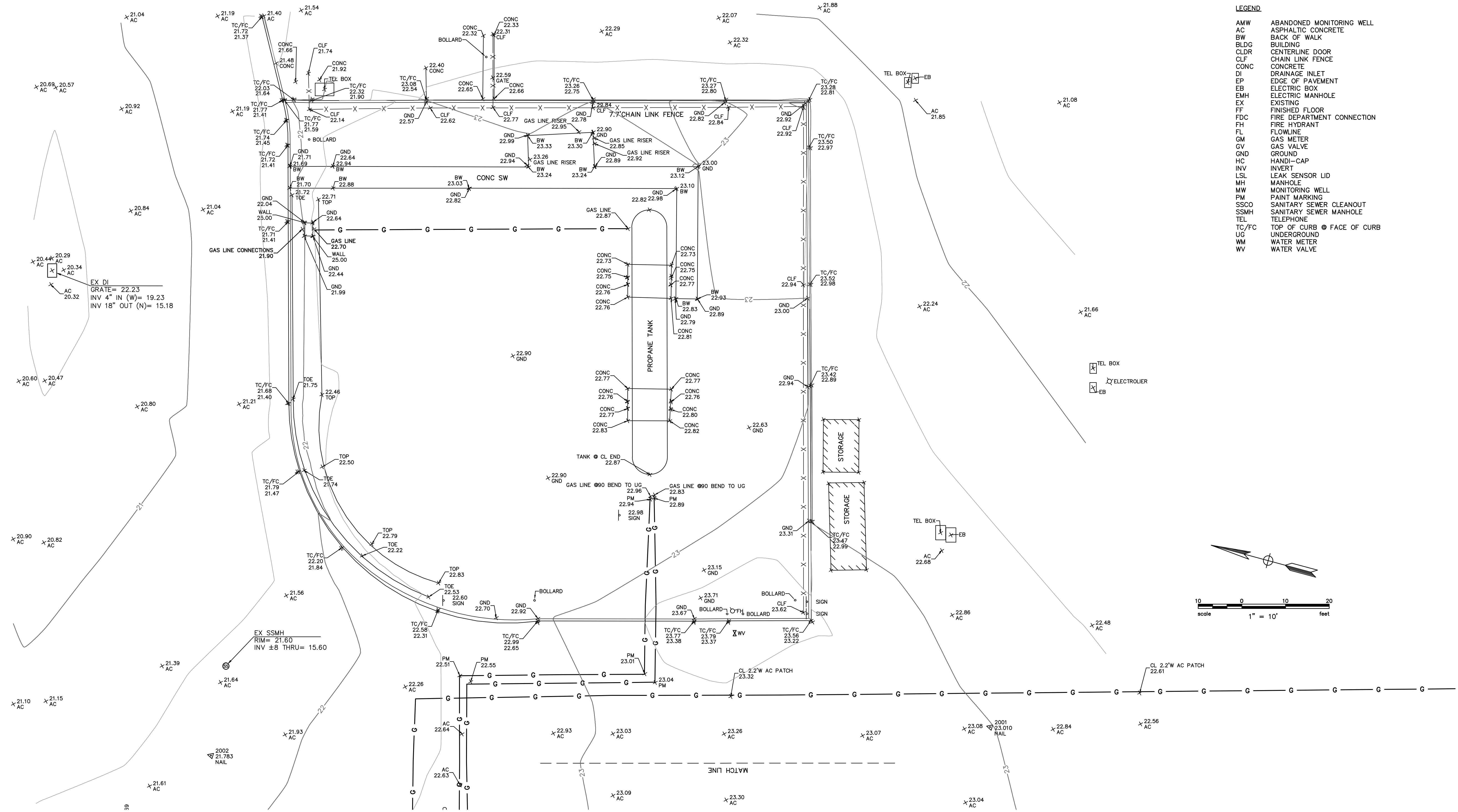

- LEGEND**
- AMW ABANDONED MONITORING WELL
  - AC ASPHALTIC CONCRETE
  - BW BACK OF WALK
  - BLDG BUILDING
  - CLDR CENTERLINE DOOR
  - CLF CHAIN LINK FENCE
  - CONC CONCRETE
  - DI DRAINAGE INLET
  - EP EDGE OF PAVEMENT
  - EB ELECTRIC BOX
  - EMH ELECTRIC MANHOLE
  - EX EXISTING
  - FF FINISHED FLOOR
  - FDC FIRE DEPARTMENT CONNECTION
  - FH FIRE HYDRANT
  - FL FLOWLINE
  - GM GAS METER
  - GV GAS VALVE
  - GND GROUND
  - HC HANDI-CAP
  - INV INVERT
  - LSL LEAK SENSOR LID
  - MH MANHOLE
  - MW MONITORING WELL
  - PM PAINT MARKING
  - SSCO SANITARY SEWER CLEANOUT
  - SSMH SANITARY SEWER MANHOLE
  - TEL TELEPHONE
  - TC/FC TOP OF CURB @ FACE OF CURB
  - UG UNDERGROUND
  - WM WATER METER
  - WV WATER VALVE

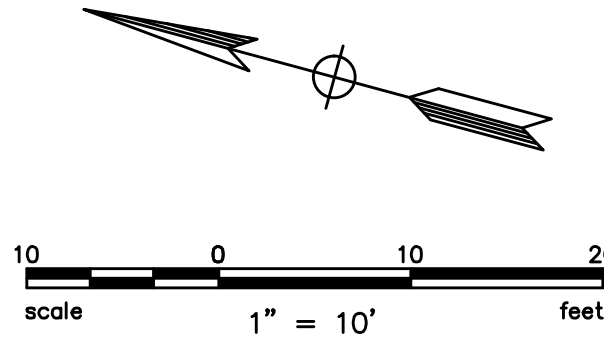

DATE PLOTTED: 02/22/2014 10:58 AM USER: J... PROJECT: ...

No.	Revisions

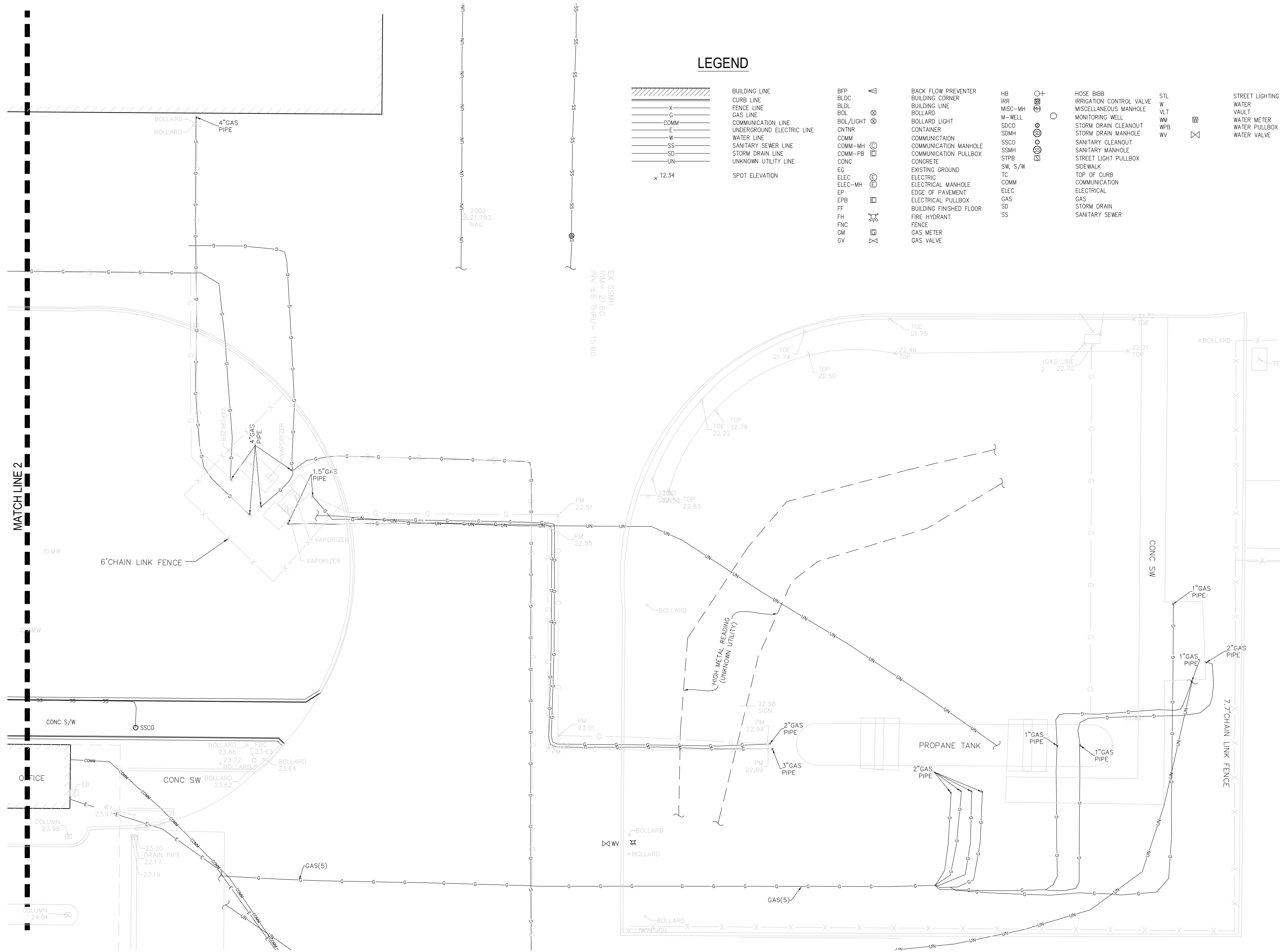

**LEGEND**

	BUILDING LINE		BACK FLOW PREVENTER		STREET LIGHTING
	CURB LINE		BUILDING CORNER		WATER VAULT
	FENCE LINE		BUILDING LINE		WATER METER
	GAS LINE		BUILDING LINE		WATER PULLBOX
	COMMUNICATION LINE		BUILDING LINE		WATER VALVE
	UNDERGROUND ELECTRIC LINE		BOLLARD		
	WATER LINE		BOLL/LIGHT		
	SANITARY SEWER LINE		CNTNR		
	STORM DRAIN LINE		COMM		
	UNKNOWN UTILITY LINE		COMM-MH		
	SPOT ELEVATION		COMM-PB		
			CONC		
			EG		
			ELEC		
			ELEC-MH		
			EP		
			EPB		
			FF		
			FNC		
			GM		
			GV		
			HB		
			IRR		
			MISC-MH		
			M-WELL		
			SDOO		
			SDOH		
			SSCO		
			SSMH		
			STPB		
			SW, S/W		
			TC		
			COMM		
			ELEC		
			GAS		
			SD		
			SS		
			HOSE BIBB		
			IRRIGATION CONTROL VALVE		
			MISCELLANEOUS MANHOLE		
			MONITORING WELL		
			STORM DRAIN CLEANOUT		
			STORM DRAIN MANHOLE		
			SANITARY CLEANOUT		
			SANITARY MANHOLE		
			STREET LIGHT PULLBOX		
			SIDEWALK		
			TOP OF CURB		
			COMMUNICATION ELECTRICAL		
			GAS		
			STORM DRAIN		
			SANITARY SEWER		

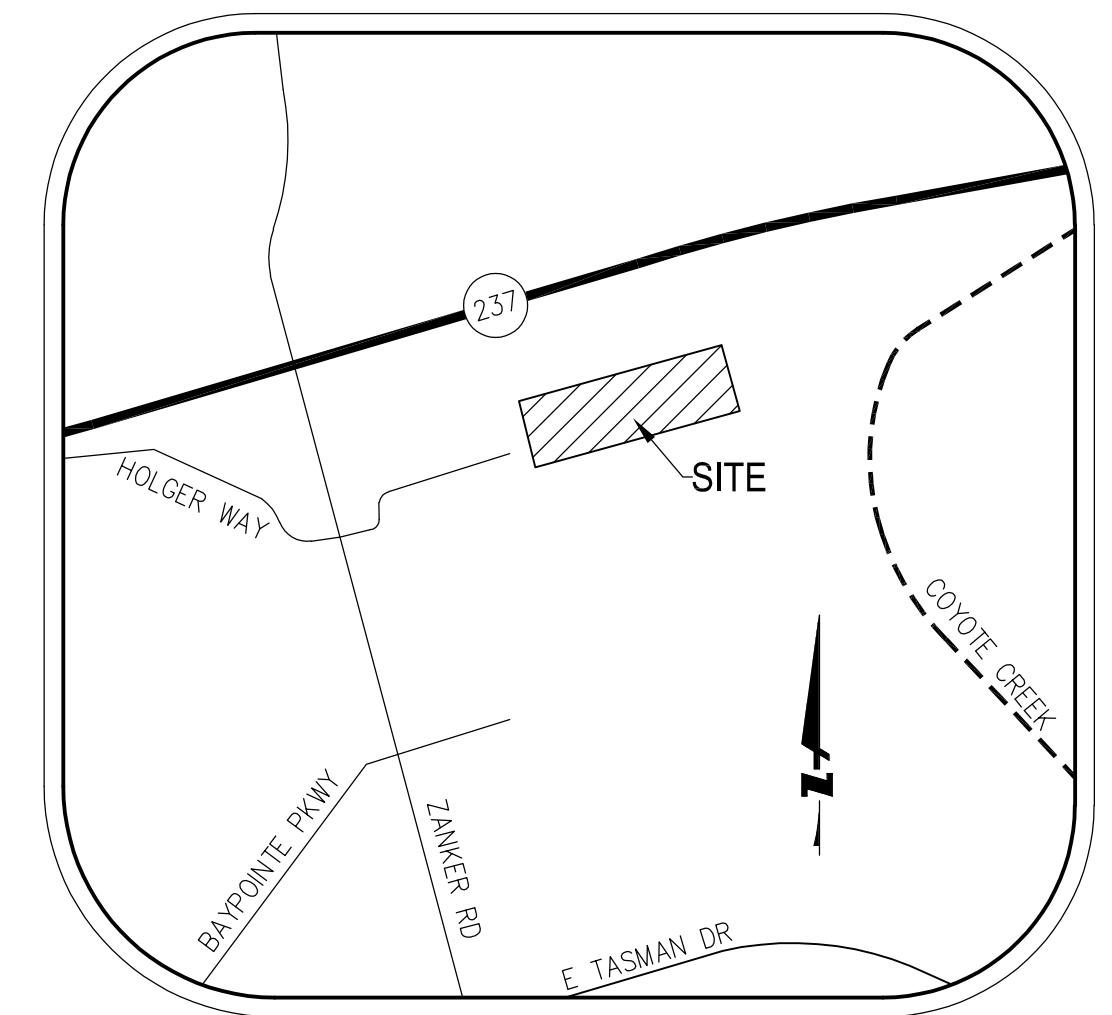

VICINITY MAP  
N.T.S.

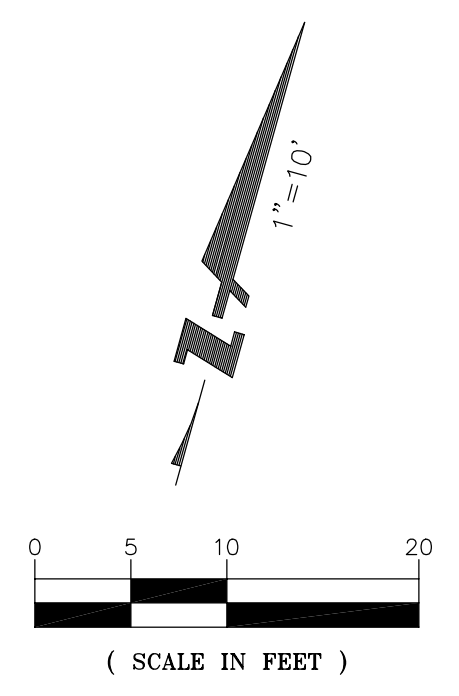

**SURVEY NOTES**

- ALL DISTANCES AND DIMENSIONS ARE SHOWN IN FEET AND DECIMALS THEREOF.
- DATES OF FIELD SURVEY: APRIL 2018
- UTILITY NOTE: THE TYPES, LOCATIONS, SIZES AND/OR DEPTHS OF EXISTING UNDERGROUND UTILITIES AS SHOWN ON THIS TOPOGRAPHIC SURVEY ARE BASED ON BKF UTILITY LOCATORS. BKF PERFORMED THE UTILITY INVESTIGATION SERVICES USING INDUSTRY ACCEPTABLE METHODS TO DETERMINE THE APPROXIMATE HORIZONTAL POSITION AND DEPTH OF EXISTING UTILITIES ON THE SUBJECT SITE. ONLY ACTUAL EXCAVATION WILL REVEAL THE TYPES, EXTENT, SIZES, LOCATIONS AND DEPTHS OF SUCH UNDERGROUND UTILITIES. A REASONABLE EFFORT HAS BEEN MADE TO LOCATE AND DELINEATE ALL KNOWN UNDERGROUND UTILITIES. HOWEVER, GIVEN THE CURRENT TECHNOLOGICAL LIMITATIONS OF THE LOCATING EQUIPMENT, A GUARANTEE AS TO ALL UTILITIES CANNOT BE MADE.
- UTILITY LOCATING REPORT: BKF UTILITY LOCATING CREW WENT OUT TO THE VTA CERONE YARD ON DIFFERENT DATES TO DO A UTILITY LOCATE. ON THE FIRST DAY THE CREW MET WITH JOHN O'BRIEN AND MOHAMED BASMA ON SITE AND WENT OVER THE SCOPE OF WORK. JOHN SHOWED THE CREW THE AREAS WHERE THEY PLAN ON DOING WORK. JOHN AND THE CREW BOTH AGREED TO THE CHANGE OF SCOPE THAT WAY THE CREW COULD FOCUS MORE ON WHERE THEY ARE PLANNING ON DIGGING. THE CREW LOCATED MULTIPLE HIGH VOLTAGE LINES BETWEEN 7-10 LINES, AND MULTIPLE COMMUNICATION LINES BETWEEN 7-10 LINES. THEY LOCATED SITE LIGHT, PROPANE GAS LINES, WATER LINES AND ELECTRICAL LINES. THE CREW LOCATED CAPPED PROPANE GAS LINES NEAR THE PROPANE TANK AND WHEN THEY DID MAGNETIC SCANS THEY GOT A HIGH METAL READING NEAR THE PERIMETER OF THE LOT. THEY ALSO LOCATED THE SEWER THROUGHOUT THE SCOPE IN SOME SEWER LINES THEY COULD NOT PUSH PAST A CERTAIN AREA. AT THE END, THE CREW PERFORMED PASSIVE SCANS AND GROUND PENETRATING RADAR (GPR) WORK. THEY FOUND 3 THINGS WITH THE GPR AND GOT A RADIO SIGNAL. THE CREW COULD NOT GET A SIGNAL OFF OF ANY WATER VALVE OR PIV AND FIRE HYDRANT. THEY ALSO COULD NOT SEE SOME UTILITIES THAT THEY MARKED WHILE USING THE GPR. THE CREW WAS NOT ABLE TO LOCATE THE FIBERGLASS FUEL LINES AND WHERE NOT ABLE TO LOCATE ALL POSSIBLY ABANDONED LINES. THE CREW WAS NOT ABLE TO LOCATE SOME SEWER LINES DUE TO NOT HAVING ACCESS TO THE PIPE OR BEING ABLE TO SEE THE LINE INSIDE A MANHOLE. THE STORM DRAINS ALL HAD ENVIRONMENTAL PROTECTION GRATES/MESH AND THE CREW WAS NOT ABLE TO LOCATE THEM.
- TOPOGRAPHIC SURVEY DONE BY BKF ON SEPTEMBER 2014, SHOWN ON SCREENED BACKGROUND FOR REFERENCE.

NO.	DATE	REVISIONS

**SUBMITTED**

**BKF** 255 SHORELINE DR  
SUITE 200  
REDWOOD CITY, CA 94065  
650-482-6300  
650-482-6399 (FAX)

**DESIGNED**  
BS

**CHECKED**  
BS

**DRAWN**  
BC

**CADD FILE NAME**  
20180602

**Santa Clara Valley Transportation Authority**

**APPROVED**

**CADD FILE DATE**

**SCALE** 1" = 10'

**FLDT DATE**

**BOARD APPROVAL DATE**

**CERONE DIVISION  
BOILER AND PROPANE TANK  
REPLACEMENT  
EXISTING SITE PLAN**

**SHEET** 1  
**OF 3**  
**DRAWING NO.** R-1.0  
**REVISION**

**SAP NO.**      **CONTRACT NO.**      **FILE LOCATION**

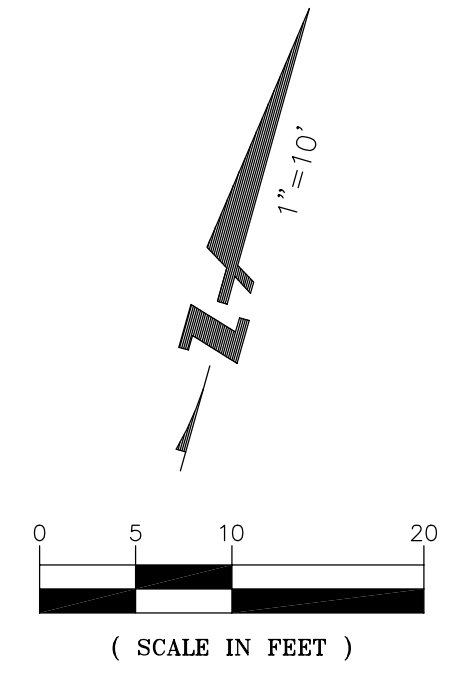
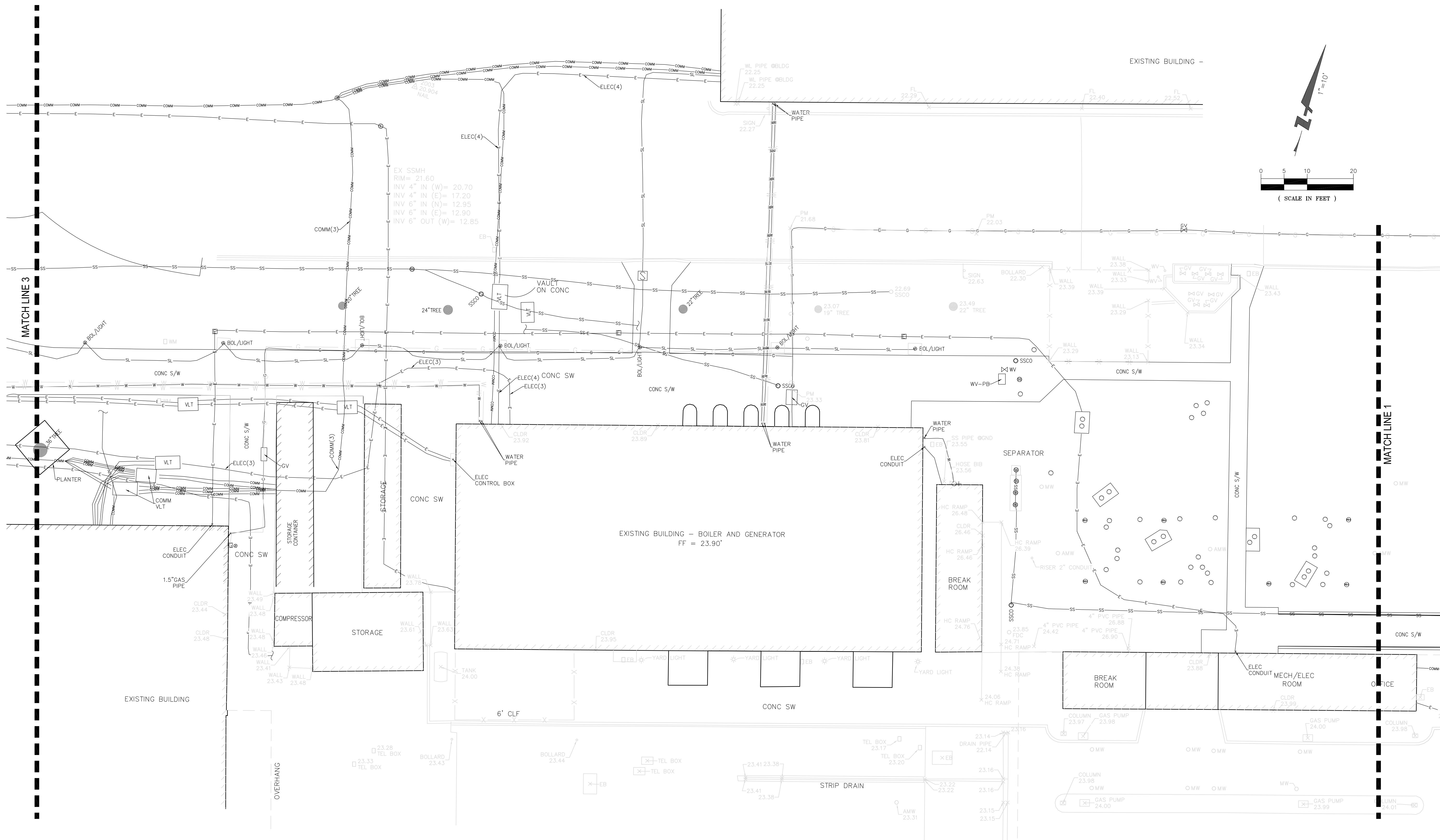

NO.	DATE	REVISIONS

**SUBMITTED**

**BKF** 255 SHORELINE DR  
SUITE 200  
REDWOOD CITY, CA 94065  
650-482-6300  
650-482-6399 (FAX)

**DESIGNED** BS

**CHECKED** BS

**DRAWN** BC

**CADD FILE NAME**  
20180602

**Santa Clara Valley Transportation Authority**

**APPROVED**

**CADD FILE DATE**      **SCALE** 1" = 10'

**PLOT DATE**              **BOARD APPROVAL DATE**

**CERONE DIVISION  
BOILER AND PROPANE TANK  
REPLACEMENT  
EXISTING SITE PLAN**

**SAP NO.**      **CONTRACT NO.**      **FILE LOCATION**

**SHEET** 2  
**OF 3**  
**DRAWING NO.** R-1.0  
**REVISION**

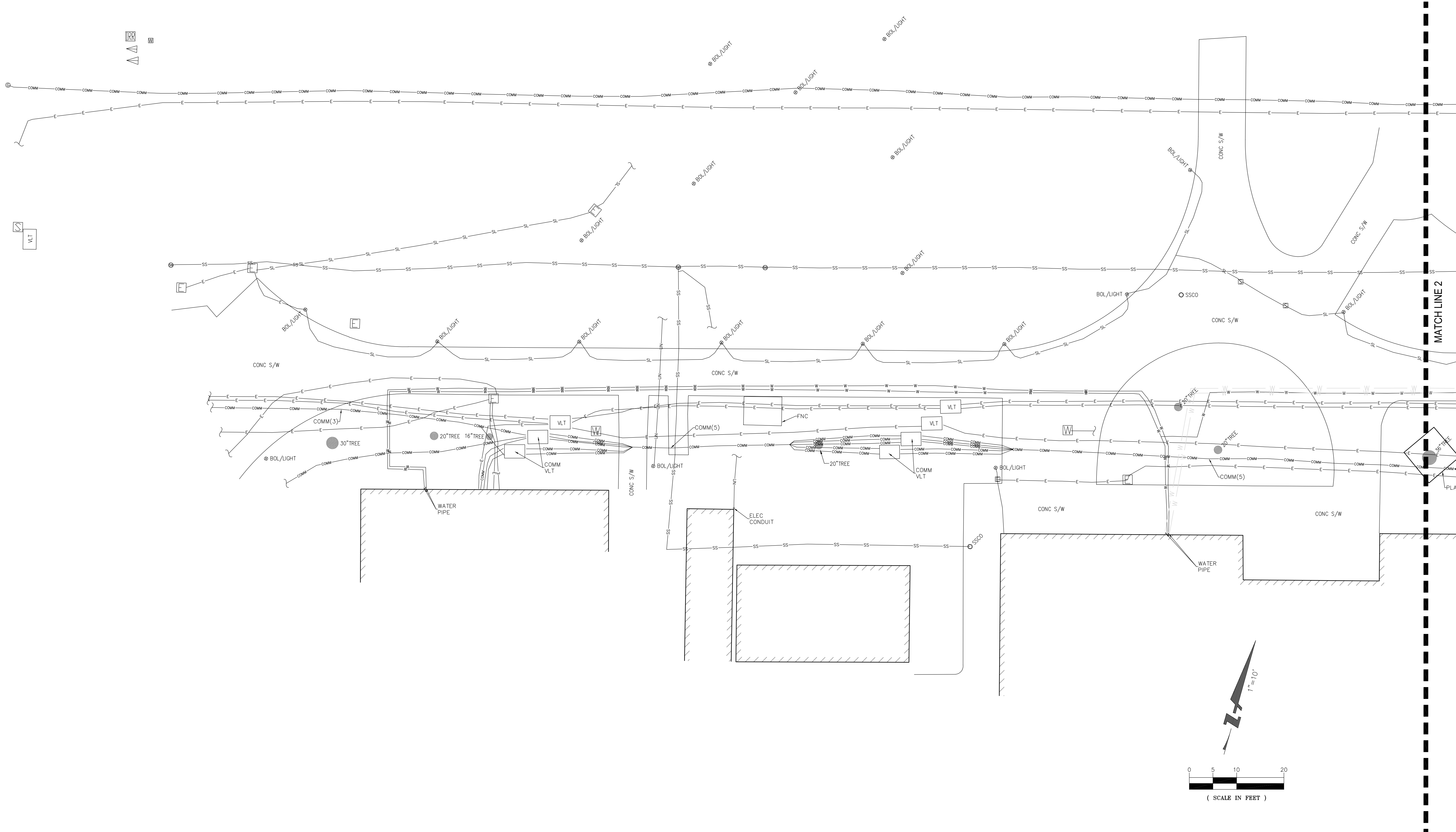

NO.	DATE	REVISIONS

**SUBMITTED**

**BKF** 255 SHORELINE DR  
SUITE 200  
REDWOOD CITY, CA 94065  
650-482-6300  
650-482-6399 (FAX)

**DESIGNED** BS

**CHECKED** BS

**DRAWN** BC

**CADD FILE NAME** 20180602

**Santa Clara Valley Transportation Authority**

**APPROVED**

**CADD FILE DATE**      **SCALE** 1" = 10'

**PLAT DATE**              **BOARD APPROVAL DATE**

**CERONE DIVISION  
BOILER AND PROPANE TANK  
REPLACEMENT  
EXISTING SITE PLAN**

**SAP NO.**      **CONTRACT NO.**      **FILE LOCATION**

**SHEET** 3  
**OF 3**  
**DRAWING NO.** R-1.0  
**REVISION**

## **APPENDIX S VTA'S PROCEDURE ON REFLECTIVE SAFETY VESTS**

Refer to Contract **Section 6.14.5 Written Safety Precautions** as an introduction to this Appendix S.

Document Number 600.009 is provided in the following pages.



*[This Page Intentionally Left Blank]*

<b>PROCEDURE</b> <b>REFLECTIVE SAFETY VESTS</b>	<b>Document Number:</b>	600.009
	<b>Version Number:</b>	01
	<b>Date:</b>	01/10/2019

**1. Purpose:**

To outline when reflective safety vests are required to be worn by employees, contractors and visitors on VTA property and in the field. This procedure also summarizes the required safety vest standards, procurement process, record-keeping practices for their distribution, and relevant training.

This policy is being written to comply with the California Division of Industrial Safety (Cal/OSHA) Title 8 3380, 20 Code of Federal Regulations (CFR) 1910.132 and American National Standard Institute/International Safety Equipment Association (ANSI/ISEA) 107- as well as VTA's Injury and Illness Prevention Program, Personal Protective Equipment Procedure.

**2. Scope:**

This procedure applies to all VTA employees, contractors and visitors working at operational divisions or in the field that require additional reflective wear to reduce the risk of hazards and injury due to lack of visibility.

**3. Responsibilities:**

**3.1. Safety and Compliance Department**

- 3.1.1. Provide safety vest guidelines to all employees that are exposed to low visibility hazards outlined in section 4.1 of this procedure.
- 3.1.2. Procure Performance Class 3 vests for employees with potential exposure to low visibility hazards in the workplace as part of their job description.
- 3.1.3. Maintain loaner Performance Class 3 vests for staff and visitors for temporarily use in situations where a low visibility hazard is present.

**3.2. Superintendents and Supervisors**

- 3.2.1. Provide awareness of low visibility hazards associated with the tasks of their employees.
- 3.2.2. Ensure that the sizes needed for their staff are available and coordinate with the Safety and Compliance Department to procure adequate supply of vests for their respective department.
- 3.2.3. Ensure that staff are wearing proper vests under necessary circumstances.
- 3.2.4. Take appropriate action if when safety vests are not being used in accordance with this procedure. Appropriate action includes providing additional training and/or imposing progressive discipline to ensure future compliance.

**3.3. Employees**

- 3.3.1. Use the reflective safety vest as instructed to eliminate the hazards associated with a lack of visibility.

<b>PROCEDURE</b> <b>REFLECTIVE SAFETY VESTS</b>	<b>Document Number:</b>	600.009
	<b>Version Number:</b>	01
	<b>Date:</b>	01/10/2019

- 3.3.2. Maintain safety vests in a safe and sanitary condition and replace when lost, damaged, worn and/or no longer reflective.
- 3.3.3. Inspect the safety vest before use and notify their supervisor if the vest is found to be damaged. Defective vests shall not be worn.
- 3.3.4. Report any violations of this policy to their supervisor in accordance with SSS-SAF-IIPP-0100 and SSS-SAF-IIPP-0600.

#### **4. Procedure:**

- 4.1. VTA employees, contractors and visitors on, whether at operating divisions or in the field, are required to always wear a high-visibility, reflective safety vest in the following conditions:
  - 4.1.1. Within ten (10) feet of the rail right-of-way.
  - 4.1.2. In low light / low visibility conditions that include rain, night, dusk and dawn.
  - 4.1.3. Near congested traffic areas and/or conditions where there is a potential hazard of being hit by a moving vehicle.
  - 4.1.4. In or near construction zones.
- 4.2. VTA Safety Vest Standards
  - 4.2.1. Garments must meet the Performance Class 3 requirements. The safety vest manufacturers label must also state that the garment meets the aforementioned standard.
  - 4.2.2. High visibility vests must be fluorescent yellow-green.
  - 4.2.3. Employees working outside must wear safety vests on the outside of their gear unless Class 3 reflective foul weather gear is worn.
  - 4.2.4. Reflective high visibility vests must have the company logo or name on the front and the back of the garment.
  - 4.2.5. All vests that require flame-resistant or arc protection need to be Class 3 and labeled accordingly.
  - 4.2.6. Alterations and modifications are prohibited with the exception of labelling with name and badge number.
  - 4.2.7. VTA high visibility vests must have a reflective chevron or an "X" on the back.
- 4.3. VTA Safety Vest Procurement
  - 4.3.1. VTA's Safety and Compliance Department will only procure Performance Class 3 vests for employees exposed to the hazards outlines in section 4.1.
  - 4.3.2. VTA's Safety and Compliance Department reserves the right to charge the appropriate cost center of the party requesting permanent safety vests in the event where vests are lost, quickly damaged (beyond the reasonable expectation of wear

<b>PROCEDURE</b> <b>REFLECTIVE SAFETY VESTS</b>	<b>Document Number:</b>	600.009
	<b>Version Number:</b>	01
	<b>Date:</b>	01/10/2019

and tear for specific job classifications), ordered in excess, and/or not required for the job hazards of the requesting party or the intended user.

- 4.3.3. If department employees are equipped with Type E rated pants, vests meeting the Performance Class 2 rating may be purchased by department heads from their associated cost center, once approved by Safety and Compliance. Performance Class 2 safety vests paired with Class E rated pants, in combination, create a Class 3 rated ensemble.

**5. Definitions:**

- 5.1. American National Standard Institute/International Safety Equipment Association 107 (ANSI/ISEA 107): Industry standard for high visibility apparel for workers exposed to the occupational hazards associated with low visibility.
- 5.2. Personal Protective Equipment (PPE): Includes all clothing and other work accessories designed to protect against work place hazards.
- 5.3. Performance Class 2 or 3 Reflective Safety Vest (“Performance Class 2” or “Performance Class 3”): A rating that designates the visibility of a garment based on the amount of background and retroreflective material in ANSI/ISEA 107.
- 5.4. Type E: A rating for pants that is based on the amount of background and retroreflective material in ANSI/ISEA 107.

**6. Records:**

- 6.1. Safety Vest Logs
  - 6.1.1. When Safety and Compliance issues reflective vests, a log indicating the date, badge number and size of vest issued will be maintained.
  - 6.1.2. When supervisors request vests from the Safety and Compliance Department, a signature of receipt will be required once the vests are delivered or picked up.
  - 6.1.3. Once vests are in the possession of the supervisor, the Safety and Compliance Department recommends internal tracking when safety vests are issued to specific employees.
  - 6.1.4. Loaner vests issued to staff and visitors for temporary use will be tracked with a separate Loaner Vest Log.
  - 6.1.5. The Safety and Compliance Safety Vest logs will be maintained in accordance to the Safety and Compliance Department’s record retention schedule.

**7. Appendices:**

NA.



<b>Original Date:</b> 01/10/2019	<b>Revision Date:</b> NA.	Page 3 of 4
-------------------------------------	------------------------------	-------------

<b>PROCEDURE</b>  <b>REFLECTIVE SAFETY VESTS</b>	<b>Document Number:</b>	600.009
	<b>Version Number:</b>	01
	<b>Date:</b>	01/10/2019

**8. Training Requirements:**

- 8.1. Training for the Reflective Safety Vest Procedure will occur alongside PPE tailgates and through the use of an Operations Notice annually.
- 8.2. PPE Tailgates are prepared by the Environmental Health and Safety Unit and are delivered by department supervisors in accordance with SSS-SAF-IIPP-0401.
- 8.3. The department issuing vests to staff, contractors and visitors shall ensure review of this procedure each time a vest is issued. The signing of the log will also signify that training has been completed.

**9. Summary of Changes:**

NA.

**10. Approval Information:**

<i>Prepared by</i>	<i>Reviewed by</i>	<i>Approved by</i>
DocuSigned by:  85108B4D547C4C5...  Karly Hutchinson Environmental Health and Safety Specialist	DocuSigned by:  FFF7F2333043470...  Angelique Gaeta VTA's Chief of Staff/Interim Director of Safety and Compliance	DocuSigned by:  E4CE93FA2C8C410...  Nuria I. Fernández General Manager/CEO

Date Approved: 3/6/2019

## **APPENDIX T**

### **BUILDING G – REFERENCE DRAWING HEATING HOT WATER SUPPLY LOOPS & PROPANE DISTRIBUTION PIPING**

All information is provided as reference information only. Accuracy of information is not guaranteed. Site conditions may have changed since the pipe mapping was compiled. Contractor must field verify accuracy.



*[This Page Intentionally Left Blank]*



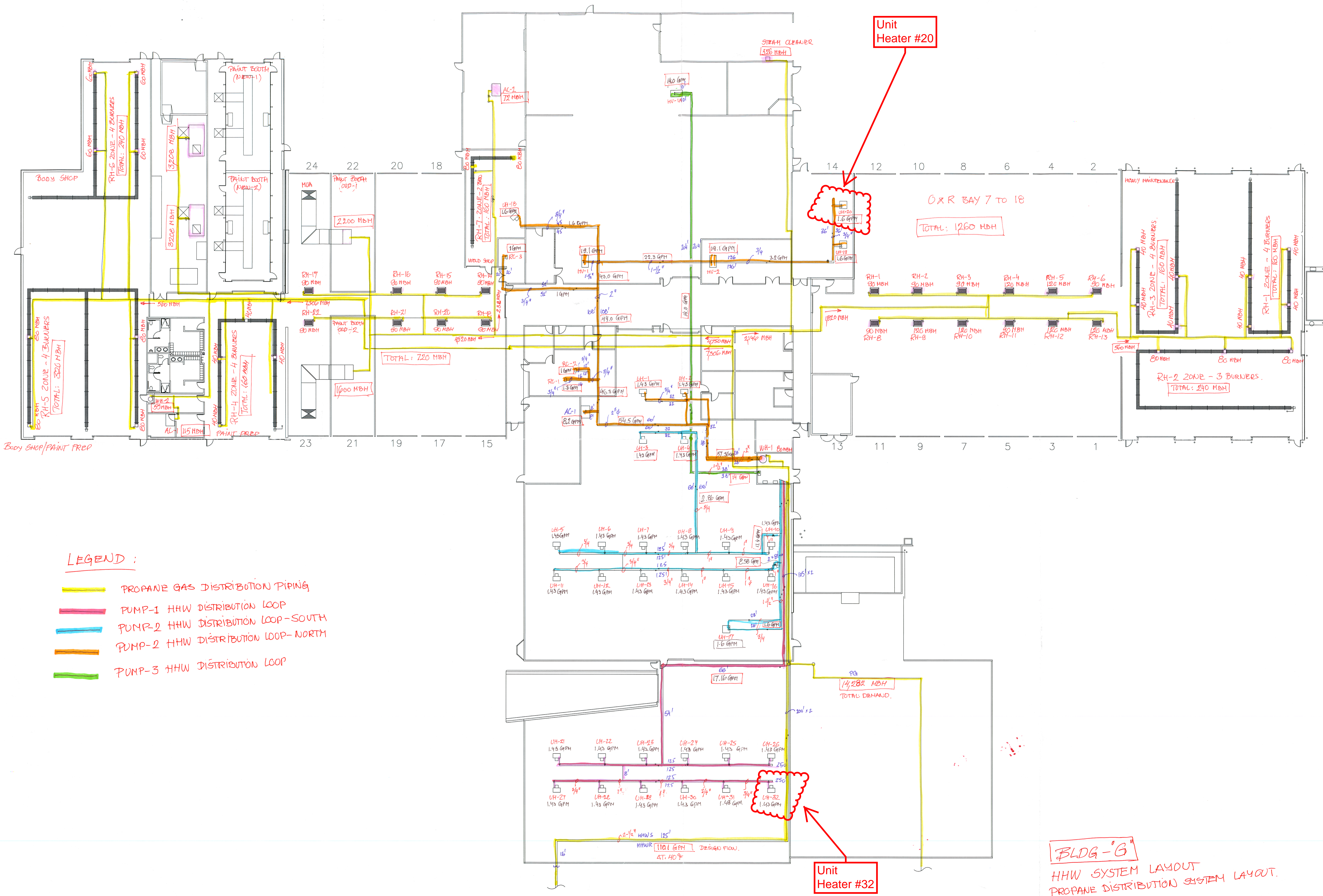

Unit Heater #20

Unit Heater #32

**LEGEND :**

- PROPANE GAS DISTRIBUTION PIPING
- PUMP-1 HHW DISTRIBUTION LOOP
- PUMP-2 HHW DISTRIBUTION LOOP-SOUTH
- PUMP-2 HHW DISTRIBUTION LOOP-NORTH
- PUMP-3 HHW DISTRIBUTION LOOP

**BLDG - G**  
 HHW SYSTEM LAYOUT  
 PROPANE DISTRIBUTION SYSTEM LAYOUT.



EXISTING-CORRECTED-HHW FLOW DIAGRAM

UNIT HEATER 32

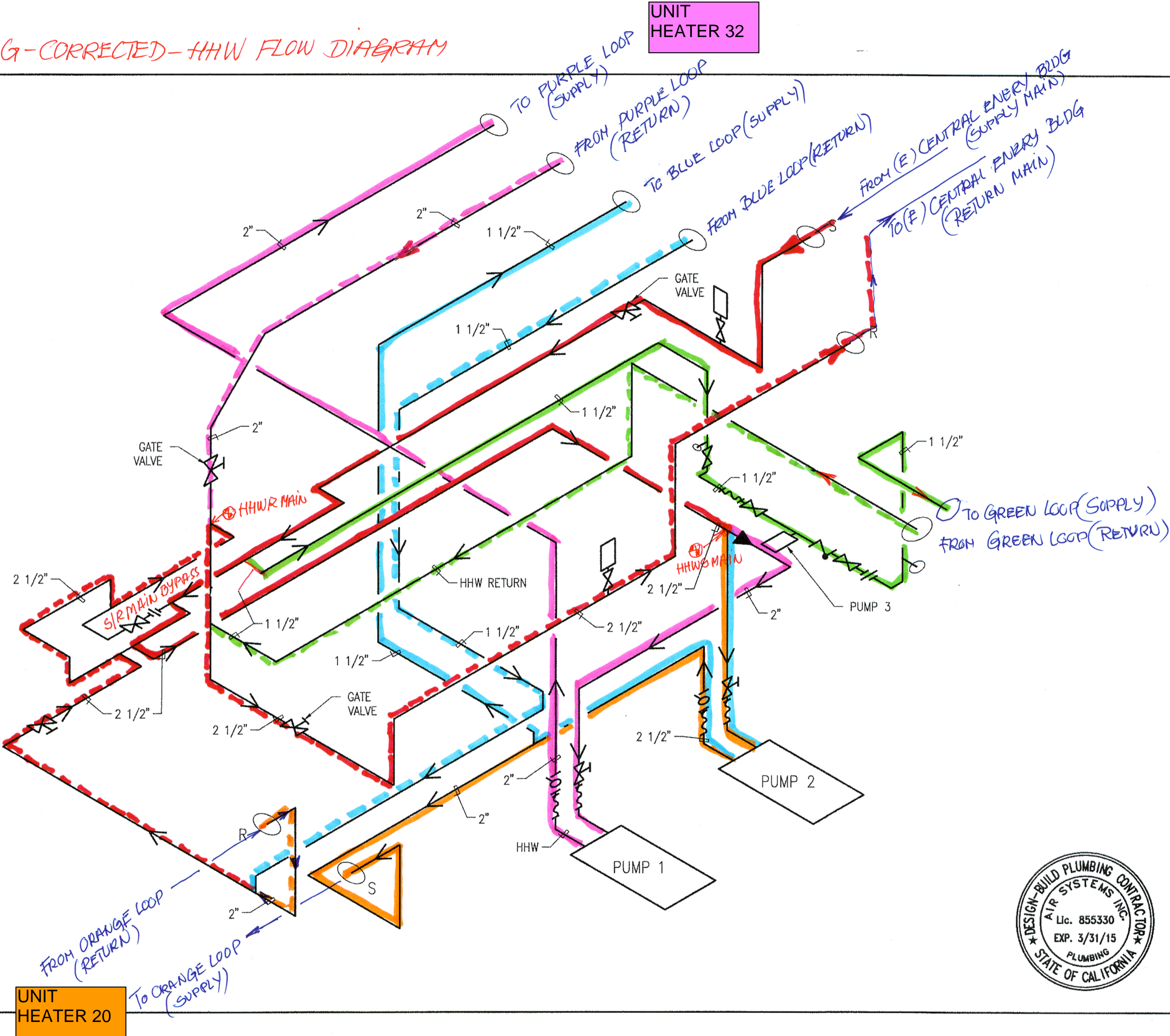

UNIT HEATER 20



PLUMBING ISOMETRIC		PSK-1	
		JOB NUMBER:	DATE:
PLUMBING ISOMETRIC		DRAWN BY:	
VTA - CERONE BLDG 6		CHECKED BY:	
<p><b>Air Systems</b>          An EMCOR Company          940 REMILLARD COURT, SAN JOSE, CALIFORNIA 95122          PHONE (408) 280-1666 FAX (408) 280-1020 LIC#855330</p>		SCALE: NONE	